

Fibre Optic Networking Products **Catalogue**

CONTENT INDEX

	<i>Pages</i>
ACTIVE NETWORKING	
Industrial Gigabit Ethernet to Fibre Media Converter	8-9
ICL 10/100/1000 Mbps Media Converter	10-12
DIN Rail Media Converter	13
Mini-GBIC SFP Transceivers	14-16
Planar Lightwave Circuit (PLC) Splitter Range	17-24
Splitter Panel	25
QSFP+ Passive Copper Cable	26-28
40Gb/s QSFP+ to 4 x SFP+ Breakout Active Optical Cable	29
40Gb/s (QSFP + SR4) Optical Module	30-31
4, 8, 16, 18 Channels CWDM OADM Module	32-33
PASSIVE NETWORKING	
Bespoke Adapters	35
Bespoke Connectors & Adapters	36
E2 / UPC - E2 / E2A Connector / Adapter	37
FC Connector/Adapter	38
Harsh Environment LC Connector Assembly	39
LC Connector/Adapter	40-43
LC Quad Adapters	44
MTRJ System	45
MU Connectors	46
SC Connector/Adapter	47
Secure Lock LC Connectors	48-49
ST Connector / Adapter	50
LC Field Installable Connector (FIC)	51
SC Field Installable Connector (FIC)	52
ST Field Installable Connector (FIC)	53
Fixed Attenuators	54
Attenuated Patch Cords (In-Line)	55
Fibre Optic Multimode Patchcords	56
Fibre Optic Patch Cord (Singlemode)	57-58
Flat Duplex Patchcord	59-60
LED Patch Cords	61
Mode Conditioning Patchcords	62
SC APC Patch Cord (Singlemode)	63
Secure Locking Fibre Optic Patch Cords	64-65
Steel Tape Armoured Patchcord	66
Single & Multi Fibre Launch Boxes	67
Multimode Pigtailed	68
Singlemode Pigtailed	69
SC/APC Pre-Connectorised 2F MINI 2.5 Pigtail Reel	70
Pre-Terminated Fibre Solutions	71
Breakout Cable 2 - 16 fibre (with 2mm sub cables)	72
Breakout Cable 24 - 48 fibre (with 2mm sub cables)	73

	<i>Pages</i>
Military Breakout Cable (Up To 12 Fibres)	74
Military Distribution Cable (Up To 12 Fibres)	75
External Loose Tube Cable 16-144 core	76
Non-Armored Multi-Tube Cable	77-78
Single Loose Tube Cable 2-24 core	79
STA Loose Tube Cable 2-24 core	80
STA Loose Tube Cable 16-144 Fibre	81
Tight Buffered Distribution Cable	82
MPO-MTP	
High Density 1U MTP Fibre Panel	84
MTP/MPO 4-Slot Cassette Open Panel	85
MTP/MPO 12 Cassete 2U Rack	86
MTP/MPO Max Fibre Cassette	87
Mini Keystone 4-Port	88
QSFP MTP/MPO – LC Duplex Breakout Cable	89
FIBRE MANAGEMENT	
Breakout Wallbox 6 Port SC Duplex/LC QUAD & Breakout Wallbox - 8 Port FC/ST	91
Breakout Wallbox 8 Port SC Simplex/LC Duplex	92
Tamper Proof Wall Box - 8-Port ST/FC	93
DIN Mountable Breakout Distribution Box	94
IP56 Box	95
Sliding SC Simplex / LC Duplex Patch Panel (24 ports)	96-97
Sliding SC Duplex / LC QUAD Patch Panel (24 ports)	98-99
Sliding FC / ST Patch Panel (24 ports)	100-101
2U Fixed Patch Panel	102
48-Port Telescopic ODF	103
ICL IP Metal Single-Door Lockable Wall Box	104
Double Door Lockable Wallbox	105
Dome Closure (IP68-Rated)	106
Dome Fibre Optic Splice Closure	107
Connector Adapter Dome Enclosure (IP68-Rated)	108
Mechanical Sealing Dome Closure	109
Mass-Fibre Count Dome Closure	110
Multiport Dome Closure with Direct SC Termination	111
Horizontal Splice Closure 12-96 Fiber (IP68-Rated)	112-113
Horizontal Splice Closure 144-288 Fiber (IP68-Rated)	114
Inline Horizontal Integrated Fibre Closure	115-116
Inline Horizontal Splice Closure (IP68-Rated)	117-118
96 Fibre Inline Horizontal Splice Closure (IP68-Rated)	119-120
Fibre Optic Combination Splice Closure	121
Fibre Optic Splice Multiport Closure (Max-288 Fibres)	122-123
Snap Lock Combi Closure	124
Compact Fibre Joint Closure (IP68-Rated)	125
Slim Line Fibre Closure (IP68-rated)	126

	<i>Pages</i>
IP68 Splice Closure 3 Port	127
96 Fibre Lockable Termination Enclosure (IP65 Rated)	128
24 Way Small Lockable Wall Box (IP65-Rated)	129
12 Fibre Plastic Wall Box (IP65-Rated)	130
24 Fibre Plastic Wall Box (IP65-Rated)	131
Snap-Lock Wallbox (IP65-Rated)	132
Splitter Terminal Wallbox (IP65-Rated)	133
Extra-Large Lockable Wallbox (IP65-Rated)	134
FIBRE MAINTENANCE	
1u Cable Bar With Brush-Strip	136
144 Fibre Cable Breakout Unit	137
Mass-Fibre Count Dome Closure	138
Connector Cleaner Cassette	139
One-Click Cleaner & Connector Cleaning Card	140
One-Click Cleaner & Connector Cleaning Card	141
Pre-Saturated (IPA) Wipes	142
Field Installable Connector Kit	143
FTTH	
Pre-Terminated 4-Port FTTH Wall Box	145
IP65 2 Way Small Central Lock Wall Box	146
Single-Port FTTH Hinge Wall Box	147
Mini Fibre Optic Splice Closure	148
2 way Sliding Connector Cover FTTH Box	149
4-Way Lock & Latch Wall Box (IP65-Rated)	150
4 Fibre FTTx Box /4 Fibre FTTx OSD-C Box	151
8-Fibre Universal Box (Suitable for Wall, Riser, or Floor mounting)	152
16 Fibre FTTx Outdoor Distribution Box (SC Simplex)	153
Customer Connection Terminal Box	154
FTTH Box with Perspex Cover	155
FTTH Compact IP65 Termination Box	156
FTTH Fibre Optic Terminal Box 8F	157
FTTH Fibre Optic Terminal Box (up to 16 fibres)	158
Fibre & Copper (CAT5E/6) Outlet, FTTH Outlet & FTTH Wall Plate	159
FTTH Multi-Port Series Enclosures	160
FTTH Flat Drop Cable Indoor (White)	161-162
FTTH Flat Drop Cable Outdoor	163-164
TOOLS/TEST AND MEASUREMENT	
Tri-Hole Strippers and Ratchet Crimp Tool	166
Pen Carbide Cleaver & Aramid Yarn Scissors	167
Pen-Type Visual Fault Identifier	168
Handheld Adjustable Light Source	169
Handheld Optical Power Meter	170

	<i>Pages</i>
OPTiSmart Optical Fibre Fusion Splicer (OPTISMART1200S)	171-172
Optical Fibre Identifier	173-174
Fibre Cleaver with Fibre Collector	175

Thank You...

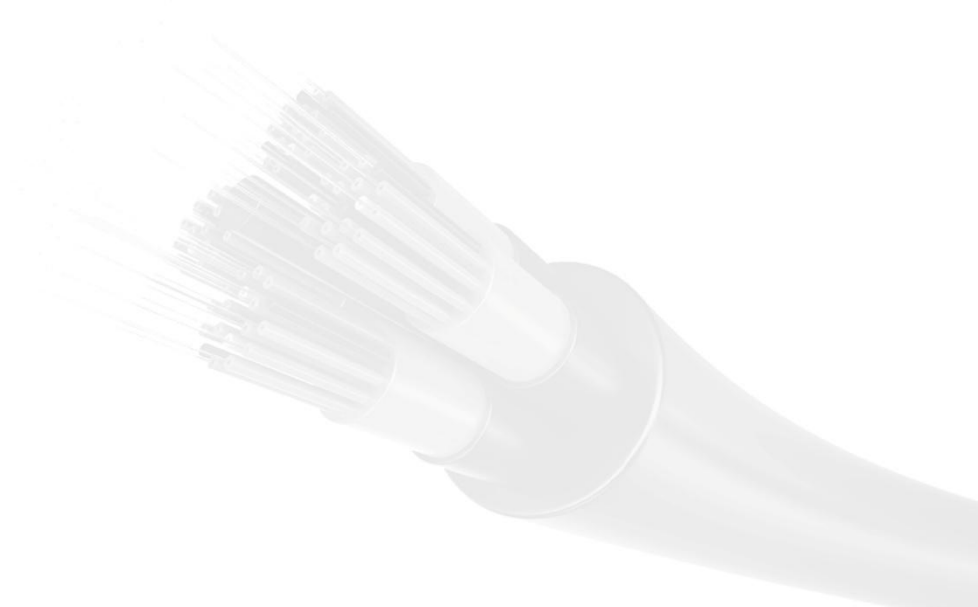

THE COMPANY

ICL International is a leading UK fibre optic manufacturer and supplier based in Milton Keynes. We specialise in the manufacture of fibre optic communication and network products for bespoke and general optical applications.

Our products range from basic passive infrastructure to active categories, including FTTX, which is the installation and use of optical fibre from a central point directly to individual buildings to provide unprecedented high speed Internet access. ICL's expansive product range is built on fundamental technologies and specialist engineering personnel, whose experience spans over forty years. The company's ethos is to present clients with cost-effective solutions, providing a high degree of reliability and outstanding performance.

We offer a comprehensive selection of fibre optic and fibre-related products to clients in different industries and regions. ICL also offers bespoke manufacturing services and we work together with our clients to provide specific solutions which meet international standards.

We constantly screen the raw materials of our products to ensure compliance with R0HS standards to protect our environment.



BESPOKE PRODUCTS	GLOBAL	INTERNATIONAL	INNOVATIVE
We manufacture bespoke products tailored to your requirements in our on-site termination house. Just ask us!	ICL has customers all over the world. From neighbouring Europe to the Middle East, our customer base continues to grow	Our international sales team can speak French, German, Spanish, Chinese and some in between. We can speak your language!	At ICL, we are always ahead of the curve with the latest optical technologies to offer our customers



QUALITY ASSURANCE:

Control monitoring and quality administration in reference to materials, etc. is achieved by our quality assurance system, which has been designed to suit current requirements of the IT and Telecommunications industries. All materials are purchased through procurement from responsible and reliable suppliers with ISO 9001 accreditation.



ACTIVE NETWORKING

Industrial Gigabit Ethernet to Fibre Media Converter

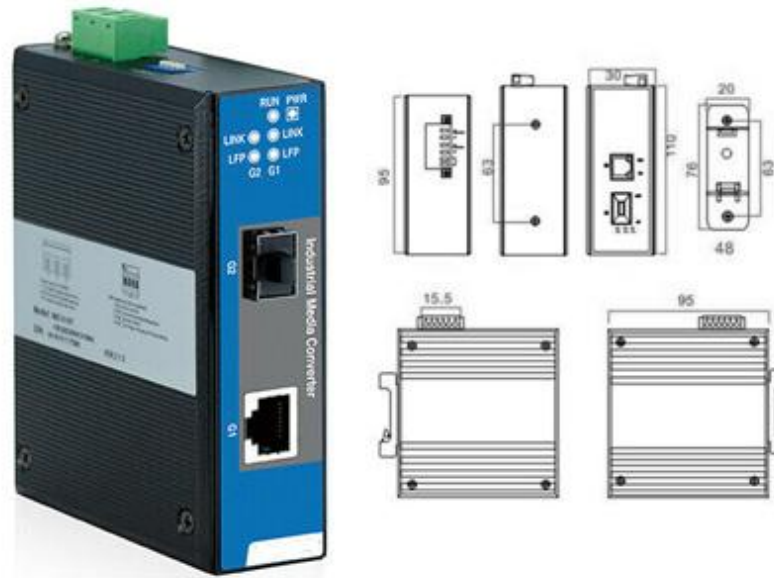

STRUCTURE DIAGRAM & DESCRIPTION

This media converter features IP40 aluminum protection, DIN rail mounting design and -40 degree C ~ 85 degree C operational temperature, with an EMC function. The unit is designed for harsh industrial environments, with 1 x 10/100/1000M BaseT (x) and 1 x 1000BaseFX.

FEATURES

- 1 x 10/100/1000BaseT(x), 1 x 1000BaseFX with SFP Socket
- Supports 10/100/1000 Mbps, with automatic MDI/MDIX
- 18~70V DC or AC 100~240V power inputs
- Industrial 4 grade
- IP40 Aluminum housing protection and DIN rail mountable
- -40 ~ +85 °C Operating Temperature Range
- Redundant dual power input
- IP40 protection, fanless design, shock resistant metal housing

TECNOLOGY - Standards

- IEEE 802.3 10BaseT
- IEEE 802.3u 100BaseT
- IEEE 802.3ab 1000BaseT
- IEEE 802.3z 1000BaseFX

PORTS

- Fiber Ports: 1000Mbps (SC)
- RJ45 Port : 10/100/1000Mbps, Full/Half duplex, MDI/MDI-X
- LED Light : PWR,ALM, L/A,SPD

PHYSICAL CHARACTERISTICS

- Housing: Aluminum, IP40 Protection
- Size: 110 x 95x 30mm
- Weight : 320g
- Installation DIN rail mountable

SWITCH PROPERTIES

- Switching bandwidth: 4Gbps
- Packet Buffer Size : 2Mb
- MAC table size : 4K
- Jumbo Frames: 9.6K Bytes

POWER REQUIREMENT

- Input Voltage : 18~70V DC, Redundant dual inputs
- Input Current : Max 0.25A

ENVIRONMENTAL PROPERTIES

- Operating temperature: -40 ~ 85°C (-40 ~ 185°F)
- Storage temperature: -40 ~ 85°C (-40 ~ 185°F)
- Ambient relative humidity: 5 ~ 95% (non-condensing)

STANDARDS AND CERTIFICATION

- EMI: FCC Part 15/CISPR22 (EN55022) : Class A
- EMS: IEC61000-4-2 (ESD) 4class, IEC 61000-4-3 (RS) 3class, IEC 61000-4-4 (EFT) 4class, IEC 61000-4-5 (Surge) 4class, IEC 61000-4-6 (CS) 3class
- Vibration: IEC 60068-2-6
- Shock: IEC 60068-2-27
- Free fall: IEC 60068-2-32

MTBF

- Time : 500000 h

PACKAGE LIST

- Switch
- Installation accessories
- User manual
- Warranty card
- QC

OPTICAL FIBRES	100 BASE FX	
	MULTI MODE	SINGLE MODE
Wavelength	850 nm	1310 / 1550nm
Maximum power	-3 dBm	0 dBm
Minimum power	-8 dBm	-10 dBm
Sensitivity	-19 dBm	-32 dBm
Link budget	11 dB	22 dB
Distance	2km ^a 550m ^b	40 km ^c
Saturability	-6 dBm	-3 dBm

AVAILABLE TYPES	PORT INTERFACE		
	10/100BaseT	10/100/1000BaseT(x)	1000BaseFX (SFP Slot)
OPTi-DIN-1GF-DC24	-	1	1
OPTi-DIN-1GF-AC220	-	1	1
OPTi-DIN-1GF-DC24-DC24	-	1	1



ICL 10/100/1000 Mbps Media Converter



STRUCTURE DIAGRAM & DESCRIPTION

This is an intelligent, adaptive and efficient Ethernet converter device. It can implement data transmission between twisted pair electrical signals and optical signals, which are the two types of network connection media. This type of media converter can extend the transmission distance to 0.55 kilometres (multimode) or 120 kilometres (single mode). Using a media converter is an economical solution to achieve a long distance transmission, based on current status.

FEATURES

- Conforms to IEEE802.3 10base-T, IEEE802.3u 100 base-TX/FX, IEEE802.3ab 1000 base-T, IEEE802.3z, 1000base-SX/LX, IEEE802.1a, IEEE802.1P/Q/S, IEEE802.1d Spanning Tree
- MDI/MDI-X Auto Negotiation
- Supports 2U 19" system chassis, holds up to 14 pieces of stand-alone type media converters or 16 pieces card-based media converters
- Hot Pluggable & Wall-Mountable
- Stable performance: more than 50,000 hours fault-free
- Unique IC solution applied
- Supports 10/100Mbps and 10/100/1000M full/half duplex, easy upgrades
- Supports VLAN transmission
- Conforms to FCC, CE and RoHS safety codes

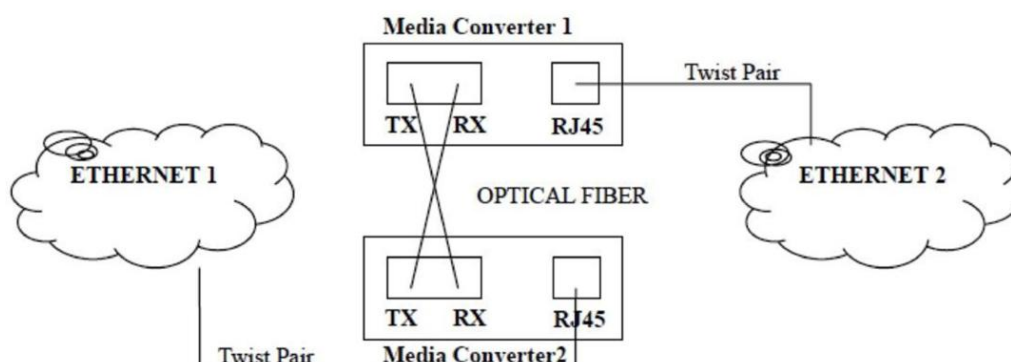

SPECIFICATIONS

Rate	self-adaptive 10/100M or 10/100/1000M
Protocol supported	IEEE802.3/IEEE802.3U etc.
Fibre type	single / dual fibre
Optic mode	single / multimode
Transmission mode	half / full duplex
Ethernet interface	RJ-45
Optic interface	SC/FC/ST
Optic wavelength	850nm, 1310nm, 1550nm, Tx1310/Rx1550nm, Tx1550/Rx1310nm
BER	< 1/1000000000
Rate	self-adaptive 10/100M or 10/100/1000M
MTBF	3 years
POWER	2.5W
Power supply	AC220V/0.5A, DC-48 V /0.5A, DC5V/1A
Working temperature	0~50oC
Working humidity	5%-95%
Storage temperature	-40oC~70oC
Storage humidity	5%~95%(no-condensing)
Weight	0.38KG
Dimensions	229x122x50mm for packing, 94x70.6x26.5mm for device

For Networking

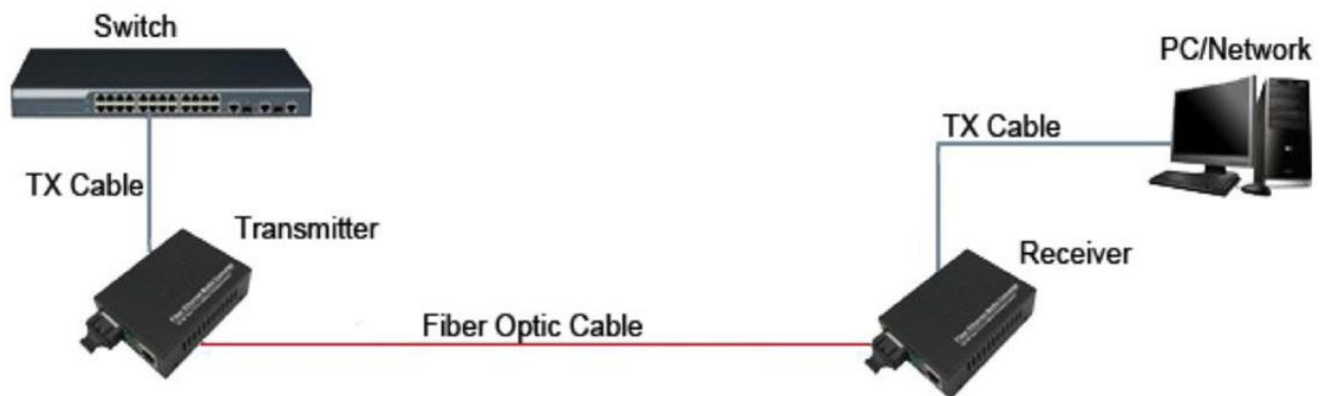

For CCTV Surveillance

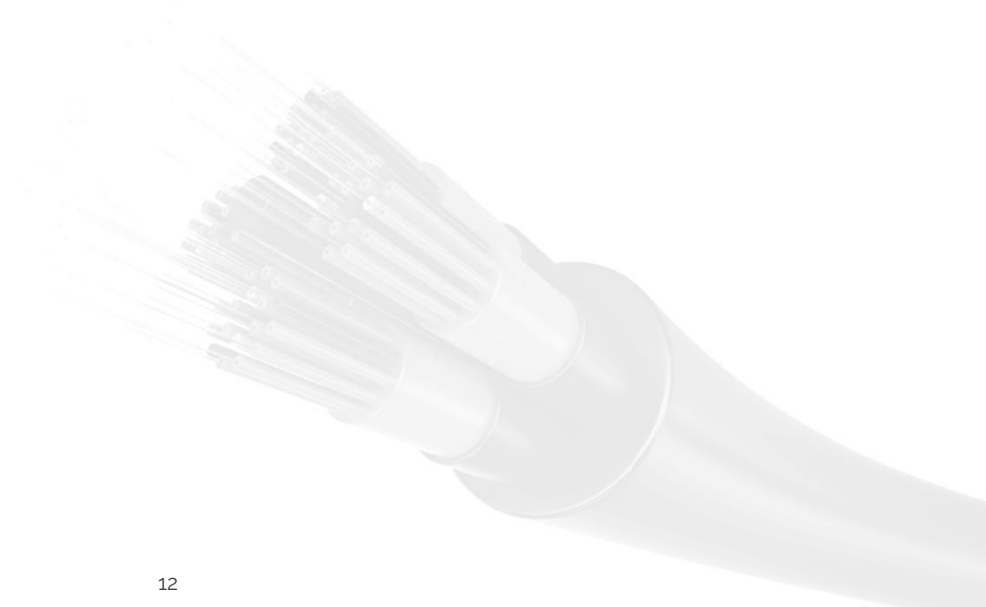
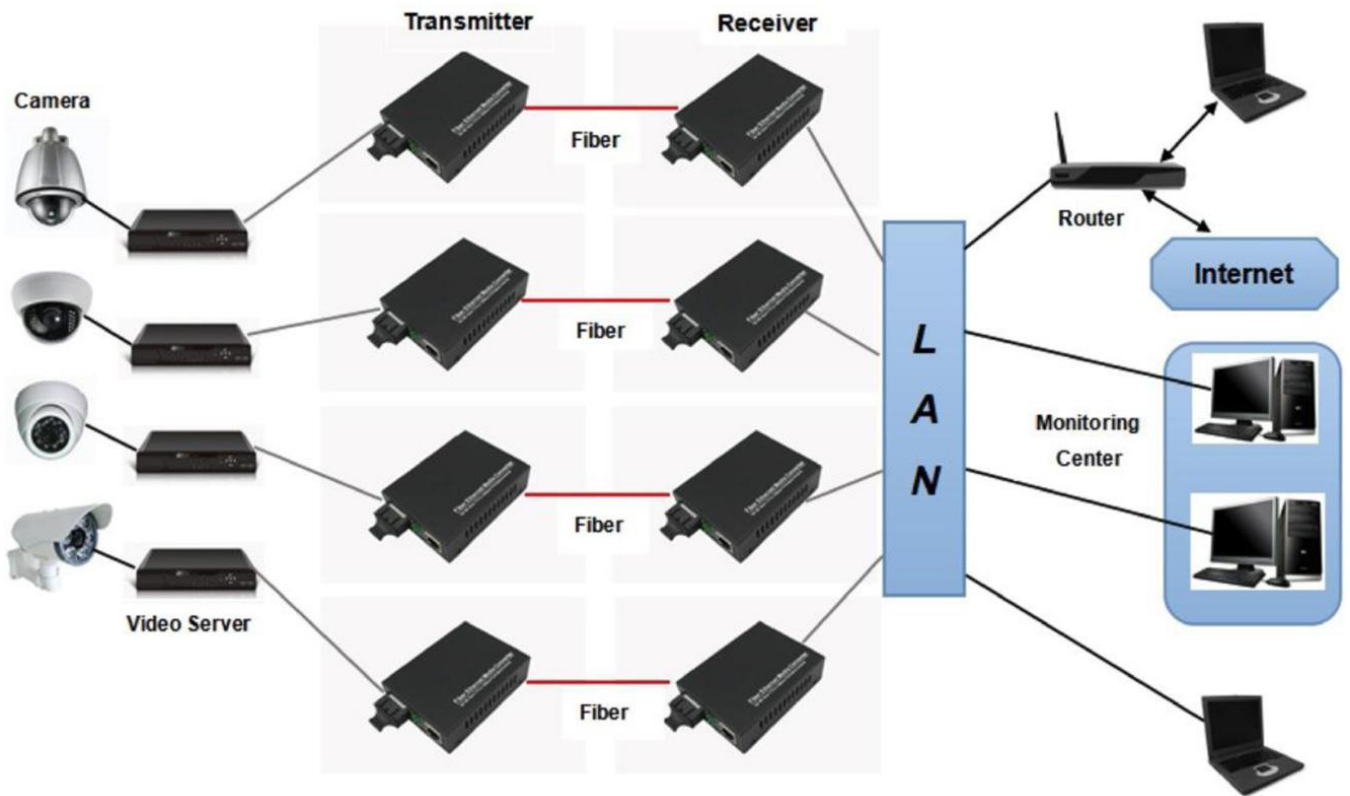

DIN Rail Media Converter



STRUCTURE DIAGRAM & DESCRIPTION

ICL's DIN rail media converters feature a clip, which allows for easy and safe attachment and removal from a DIN rail. This allows multiple media converters to be arranged for effective data transfer in network environments. Available with fibre optic adapters and SFP transceiver connectivity.

FEATURES

- Less time delay in data transfer
- Completely transparent to network protocols
- Dedicated ASIC chip to determine data wire-speed transmission
- Supports SFP optical transceiver
- Operating temperature -20°C to +70°C
- Supports transmission distance 0-120km
- DIN rail mountable
- Plastic IP30 protection



Mini-GBIC SFP Transceivers



STRUCTURE DIAGRAM & DESCRIPTION

Small Form-factor Pluggable (SFP) transceiver modules are designed for high performance integrated duplex data transmission over optical fibre. These SFP transceiver modules are compliant with the industry's SFP Multi-Source Agreement (MSA) standard. The SFP transceiver modules offer the ability to enable the SFP ports on any Ethernet equipment that have a built-in SFP Mini-GBIC interface. These modules are hot-swappable without any interruption of the host equipment operation. These SFP modules are available in 100Base-FX/BX or 1000Base-TP / FX / BX configurations, allowing for use of either one fibre or two fibre transmission over single mode or multi-mode optical fibre. Additionally, certain SFPs are available as wide-temperature versions for use in industrial equipment deployed in harsh environments.

FEATURES

DESIGN

- Plug-and-play capability for easy installation
- Hot-swappable
- Low power dissipation

OPTICAL PERFORMANCE

- Available in wide-temperature versions for harsh industrial applications
- Data rates of 100Mbps or 1.25Gbps
- Single mode or multimode fibre
- 1 or 2 fiber configurations
- RJ-45 1.25Gbps SFP available

STANDARD COMPLIANCE

- Mini-GBIC interface compliant
- Multi-source agreement (MSA) compliant
- Class 1 laser safety standard IEC 60825 compliant

ELECTRICAL AND MECHANICAL

Input Voltage	3.3V DC
Dimensions (W x D x H)	2.20 x 0.59 x 0.49 in. (59 x 15 x 12.4 mm)
Weight (ounces, grams)	0.6 oz, 18g
Storage Temperature	-40°C ~ 85°C
Relative Humidity	5% ~ 95% (non-condensing)
Relative Humidity	> 50,000 hrs @ 25° C

Mini-GBIC SFP Transceivers

STANDARDS COMPLIANCE

EMI

- EN 55022 CLASS A:2006+A1 : 2007
- EN61000-3-2:2006
- EN61000-3-3: 1995+A1:2001+A2:2005

EMS

- 55024:1998+A1:2001+A2:2003
- IEC 61000-4-2:Edition 1.2 2001-04
- IEC 61000-4-3:Edition 3.0 2006
- IEC 61000-4-4:2004
- IEC 61000-4-5:Edition 2.0 2005
- EC 61000-4-6:Edition 2.2 2006
- IEC 61000-4-8:Edition 1.1 2001-03
- IEC 61000-4-11:Second Edition : 2004-03
- IEC/EN 60950-1
- AS/NZS CISPR 22 : 2006

REGULATORY STANDARDS

- FCC Part 15 Class B, CE

SPECIFICATIONS

VeeT	Transmitter Ground
TX_FAULT	Transmitter Fault Indication
TX_DISABLE	Transmitter Disable
MOD_DEF (2)	SDA Serial Data Signal
MOD_DEF (1)	SCL Serial Clock Signal
MOD_DEF (0)	TTL Low to indicate the SFP is present
RATE SELECT	Not Connected (Open Circuit)
LOS	Receiver Loss of Signal
VeeR	Receiver Ground
RD-	Inv. Received Data Out (Differential PECL, AC coupled)
RD+	Received Data Out (Differential PECL, AC coupled)
VccR	Receiver Power Supply
VccT	Transmitter Power Supply
TD+	Transmit Data In (Differential PECL, AC coupled)
TD-	Inv. Transmit Data In (Differential PECL, AC coupled)

Mini-GBIC SFP Transceivers

Dimensional Diagrams

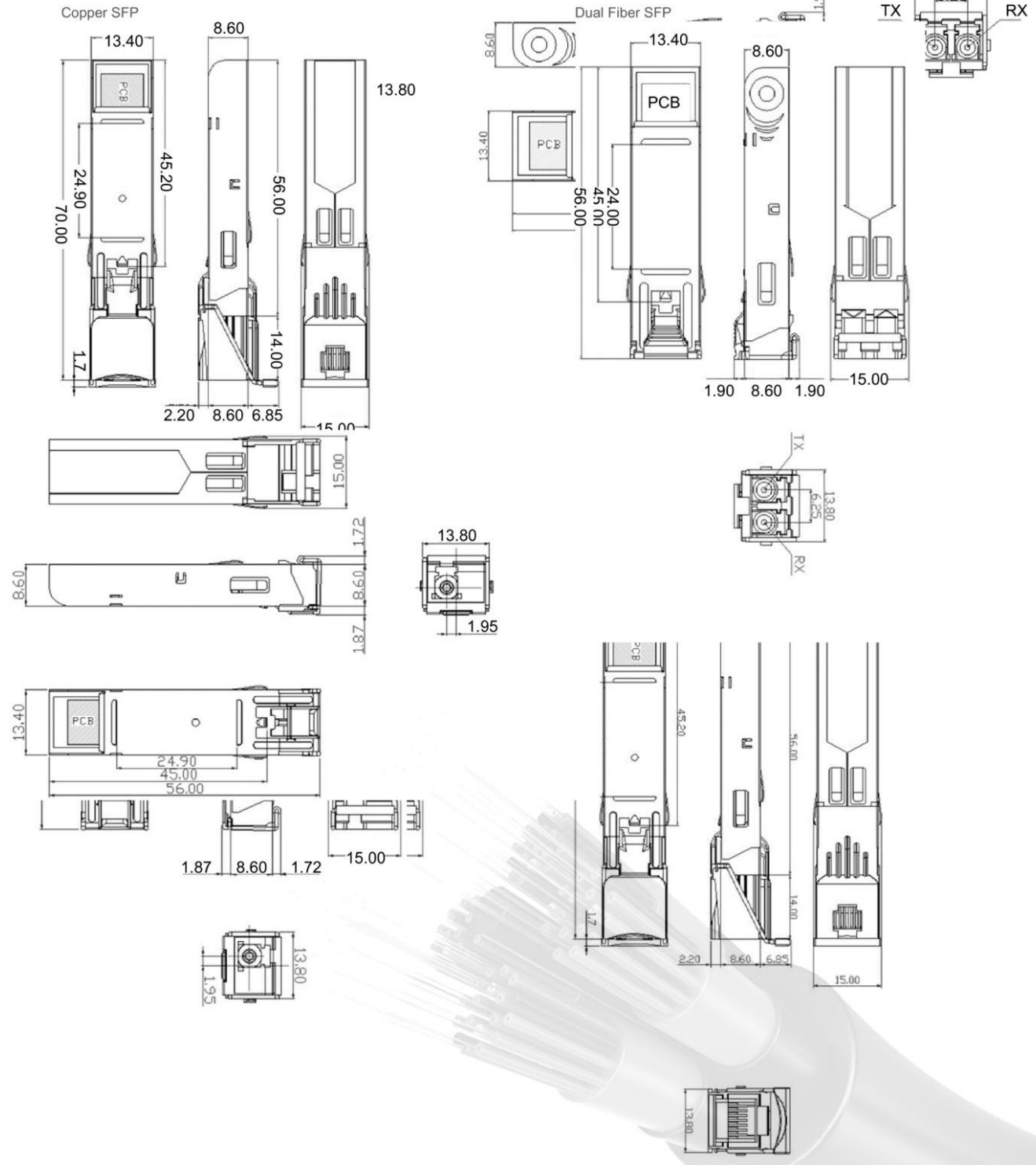

Planar Lightwave Circuit (PLC) Splitter Range

STRUCTURE DIAGRAM & DESCRIPTION

A planar lightwave circuit (PLC) splitter is a type of optical power management device that is fabricated using silica optical waveguide technology. It features small size, high reliability, a wide operating wavelength range & good channel-to-channel uniformity and is widely used in PON networks to realise optical signal power splitting.

We provide a whole series of 1xN and 2xN splitter products that are tailored for specific applications.

All products meet GR-1209-CORE-2001 and GR-1221-CORE-1999 requirements.

FEATURES

- Low insertion loss
- Low PDL
- Compact design
- Good channel-to-channel uniformity
- Wide operating wavelength: From 1260nm to 1650nm
- Wide operating temperature: From -40°C to 85°C
- High reliability and stability

COMPLIANCE

- Telcordia GR-1209-CORE-2001
- Telcordia GR-1221-CORE-1999
- RoHS

APPLICATIONS

- FTTX Systems
- PON Networks
- CATV Links
- Optical Signal Distribution

Bare Fibre PLC Splitter



APPLICATIONS

- Low insertion loss
- Low PDL
- Compact design
- Good channel-to-channel uniformity
- Wide operating wavelength: 1260-1650nm
- Wide operating temperature: -40°C to 85°C
- High reliability and stability

PACKAGING

1*2	1*4	1*8	1*16	1*32
40*4*4mm	40*4*4mm	40*4*4mm	50*7*4mm	50*7*4mm
2*2	2*4	2*8	2*16	2*32
40*4*4mm	40*4*4mm	40*4*4mm	50*7*4mm	50*7*4mm

0.9mm Steel Tube PLC Splitter

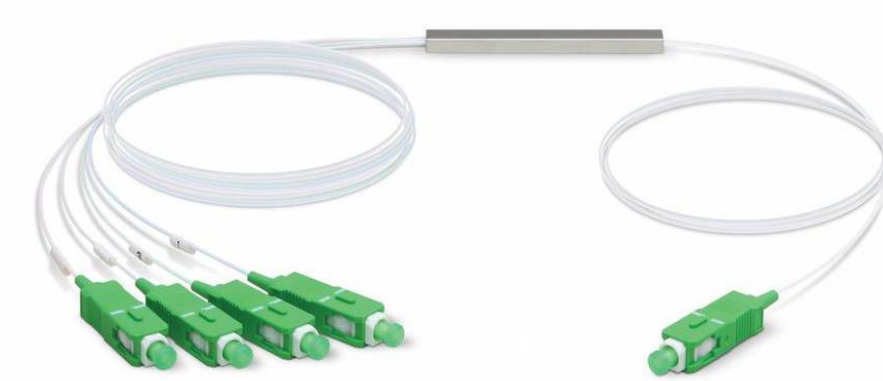

DESCRIPTION

- Low insertion loss
- Low PDL
- Compact design
- Good channel-to-channel uniformity
- Wide operating wavelength: 1260-1650nm
- Wide operating temperature: -40°C to 85°C
- High reliability and stability

PACKAGING

1*2	1*4	1*8	1*16	1*32
40*4*4mm	50*7*4mm	50*7*4mm	60*12*4mm	80*20*6mm
2*2	2*4	2*8	2*16	2*32
40*4*4mm	50*7*4mm	50*7*4mm	60*12*4mm	80*20*6mm

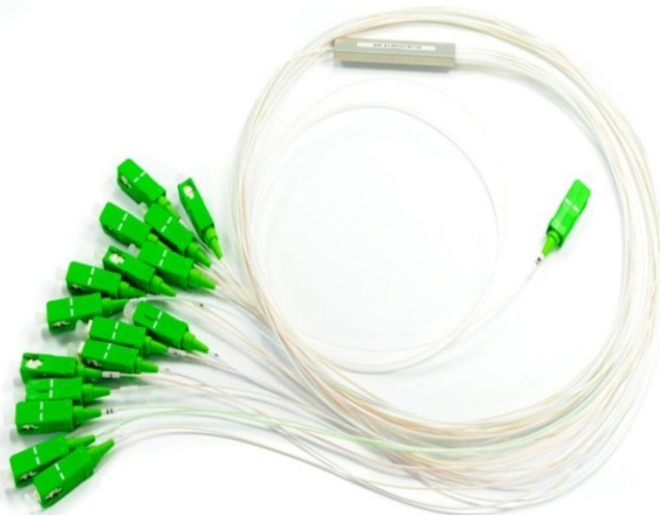

Fanout PLC splitter



DESCRIPTION

- Low insertion loss
- Low PDL
- Compact design
- Good channel-to-channel uniformity
- Wide operating wavelength: 1260-1650nm
- Wide operating temperature: -40°C to 85°C
- High reliability and stability

PACKAGING

1*2	1*4	1*8	1*16	1*32
40*4*4mm	50*7*4mm	50*7*4mm	60*12*4mm	80*20*6mm
2*2	2*4	2*8	2*16	2*32
40*4*4mm	50*7*4mm	50*7*4mm	60*12*4mm	80*20*6mm

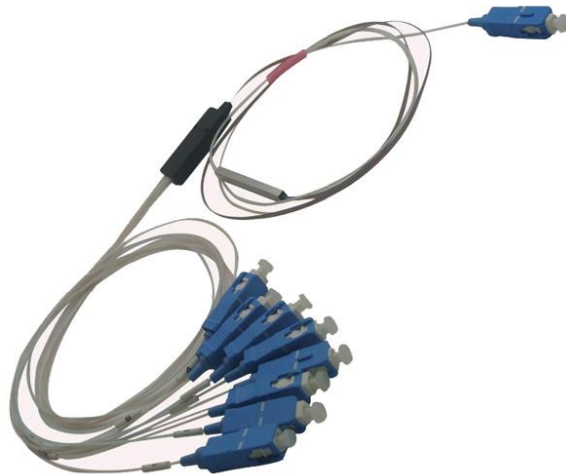

Cassette Type PLC Splitter



DESCRIPTION

- Low insertion loss
- Low PDL
- Compact design
- Good channel-to-channel uniformity
- Wide operating wavelength: 1260-1650nm
- Wide operating temperature: -40°C to 85°C
- High reliability and stability

PACKAGING

1*2	1*4	1*8	1*16	1*32
90*20*10mm	100*80*10mm	100*80*10mm	120*80*18mm	140*115*18mm
2*2	2*4	2*8	2*16	2*32
90*20*10mm	100*80*10mm	100*80*10mm	120*80*18mm	140*115*18mm



LGX PLC Splitter



DESCRIPTION

- Low insertion loss
- Low PDL
- Compact design
- Good channel-to-channel uniformity
- Wide operating wavelength: 1260-1650nm
- Wide operating temperature: -40°C to 85°C
- High reliability and stability

PACKAGING

1*2	1*4	1*8	1*16	1*32
302*180*25mm	302*180*25mm	302*180*25mm	302*180*25mm	302*180*50mm
2*2	2*4	2*8	2*16	2*32
302*180*25mm	302*180*25mm	302*180*25mm	302*180*25mm	302*180*50mm

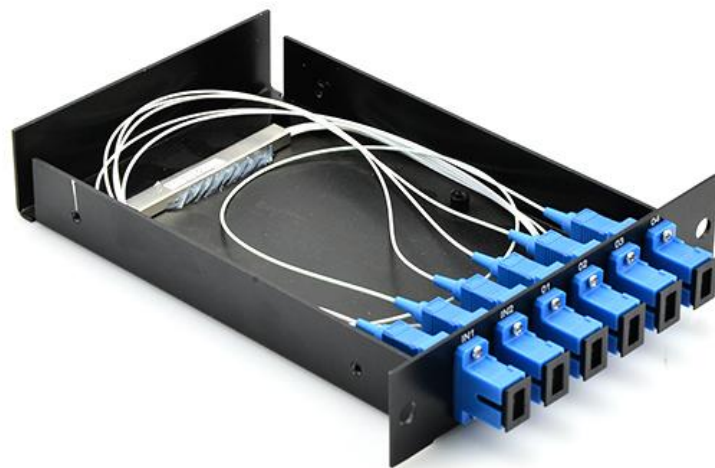

Tray Type PLC Splitter



DESCRIPTION

A tray type PLC splitter can be installed in a standard 19" fibre optic distribution frame or in a 19" fibre optic cross-connection

- Industry-standard bulkhead style
- Highest splitter densities to maximize rack space
- Flexible and scalable platforms

PACKAGING

1*2	1*4	1*8	1*16	1*32
302*180*25mm				302*180*50mm
2*2	2*4	2*8	2*16	2*32
302*180*25mm				302*180*50mm

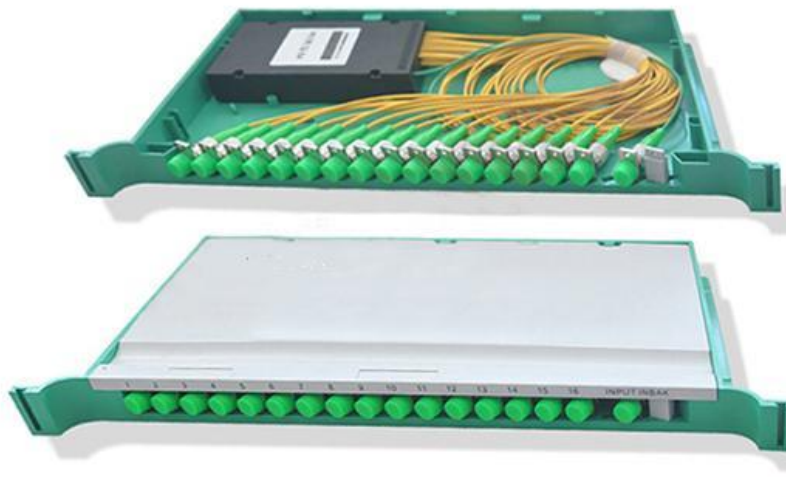

Tray Type PLC Splitter



DESCRIPTION

A tray type PLC splitter can be installed in a standard 19" fibre optic distribution frame or in a 19" fibre optic cross-connection

- Industry-standard bulkhead style
- Highest splitter densities to maximize rack space
- Flexible and scalable platforms

PACKAGING

1*2	1*4	1*8	1*16	1*32
302*180*25mm				302*180*50mm
2*2	2*4	2*8	2*16	2*32
302*180*25mm				302*180*50mm



1 XN, 2XN PLC Splitter

SPECIFICATIONS												
Parameter	1X2	2X2	1X4	2X4	1X8	2X8	1X16	2X16	1X32	2X32	1X64	2X64
Operating Wavelength (nm)	1260~1650											
Fiber Type	G657A or Customer Specified											
Insertion Loss (dB) (P/S Grade)	3.8/ 4.0	4.0/ 4.2	7.1/ 7.3	7.6/ 7.6	10.2/ 10.5	11.0/ 11.2	13.5/ 13.7	14.4/ 14.6	16.5/ 16.9	17.5/ 17.9	20.5/ 21.0	21.0/2 1.5
Loss Uniformity (dB)	0.4	0.6	0.6	1.0	0.8	1.2	1.2	1.5	1.5	2.0	2.0	2.2
Return Loss (dB) (P/S Grade)	55/50											
Polarisation Dependent Loss (dB)	0.2	0.2	0.2	0.2	0.2	0.3	0.25	0.3	0.3	0.4	0.35	0.4
Directivity (dB)	55											
Wavelength Dependent Loss (dB)	0.3	0.3	0.3	0.4	0.3	0.5	0.5	0.5	0.5	0.5	0.5	0.5
Temp. Stability (-40~85°C) (dB)	0.4	0.4	0.4	0.4	0.4	0.4	0.5	0.5	0.5	0.5	0.5	0.5
Operating Temperature (°C)	-40°C to 85°C											
Storage Temperature (°C)	-40°C to 85°C											
Device Dimension (mm) (L×W×H)	40×4×4	40× 4×4	50× 4×4	40× 4×4	50×4×4			50×7×4		60× 7×4	60×12×4	

ORDERING INFORMATION					
A	B/C	D/E	F/G	H	
PLC	Port	Input /Output Pigtail Type	Input /Output Fibre Length	Input /Output Connector	Package Type
PLC	102=1 x 2 104=1 x 4 108=1 x 8 116=1 x 16 132=1 x 32 164=1 x 64 202=2 x 2 204=1 x 4 208=1 x 8 216=1 x 16 232=1 x 32	1=900um loose tube 2=2.0mm loose tube 3=3.0mm loose tube	05=0.5M 10=1.0M 15=1.5M	0=None FU=FC/UPC FA=FC/APC SU=SC/UPC SA=SC/APC LU=LC/UPC LA=LC/APC ST=STX=Others	P2=100 x 80 x 10.5mm P3=120 x 80 x 18mm P4=140 x 115 x 18 mm XL=1,2,3,4U LGX Module X=Others

Splitter Panel



FEATURES

- Low insertion loss
- Low PDL
- Compact design
- Good channel-to-channel uniformity
- Wide operating wavelength: from 1260nm to 1650nm
- Wide operating temperature: from -40°C to 85°C
- High reliability and stability

APPLICATIONS

- FTTX Systems
- PON Networks
- CATV Links
- Optical Signal Distribution

COMPLIANCE

- Telcordia GR-1209-CORE-2001 Telcordia GR-1221-CORE-1999 RoHS

SPECIFICATIONS

Parameters	1X2	2X2	1X4	2X4	1X8	2X8	1X16	2X16	1X32	2X32	1X64	2X64
Operating Wavelength (nm)	1260~1650											
Fiber Type	G657A or customer specified											
Insertion Loss (dB) (P/S Grade)	3.8/ 4.0	4.0/ 4.2	7.1/ 7.3	7.6/ 7.6	10.2/ 10.5	11.0/ 11.2	13.5/ 13.7	14.4/ 14.6	16.5/ 16.9	17.5/ 17.9	20.5/ 21.0	21.0/ 21.5
Loss Uniformity (dB)	0.4	0.6	0.6	1.0	0.8	1.2	1.2	1.5	1.5	2.0	2.0	2.2
Return Loss (dB) (P/S Grade)	55/50											
Polarisation Dependent Loss (dB)	0.2	0.2	0.2	0.2	0.2	0.3	0.25	0.3	0.3	0.4	0.35	0.4
Directivity (dB)	55											
Wavelength Dependent Loss (dB)	0.3	0.3	0.3	0.4	0.3	0.5	0.5	0.5	0.5	0.5	0.5	0.5
Temperature Stability (-40~85°C) (dB)	0.4	0.4	0.4	0.4	0.4	0.4	0.5	0.5	0.5	0.5	0.5	0.5
Operating Temperature (°C)	-40°C to 85°C											
Storage Temperature (°C)	-40°C to 85°C											

NOTES

- Specified without connectors
- All measurements taken at room temperature

QSFP+ Passive Copper Cable



STRUCTURE DIAGRAM & DESCRIPTION

The QSFP+ passive cable assemblies are high performance, cost effective I/O solutions for 40G LAN, HPC and cost effective I/O solutions for 40G LAN, HPC and SAN applications. The QSFP+ passive copper cables are compliant with SFF-8436, QSFP+ MSA and IEEE P802.3ba 40GBASE-CR4. It offers a low power consumption, short reach interconnect applications. The cable each lane is capable of transmitting data at rates up to 10Gb/s, providing an aggregated rate of 40Gb/s.

APPLICATIONS

- 10G / 40Gigabit Ethernet
- InfiniBand 4XSDR, DDR, QDR
- Switches, Routers, and HBAs
- Data Centers
- 2, 4, 8, 10 Gigabit Fibre Channel

MECHANICAL DIMENSIONS

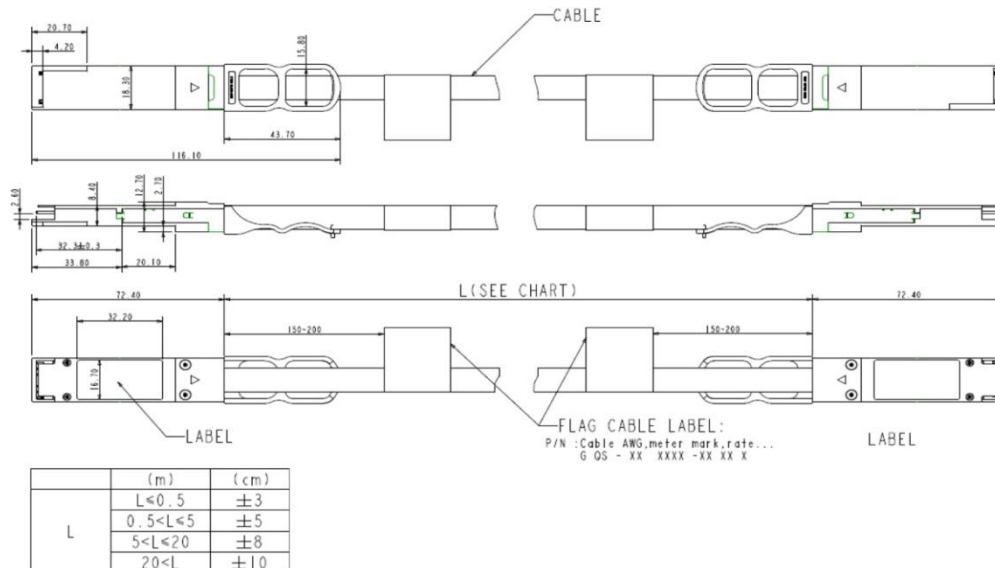

FEATURES

- QSFP+ conforms to the Small Form Factor SFF-8436
- 4-Channel Full-Duplex Passive Copper Cable Transceiver
- Support for multi-gigabit data rates :1.0 Gbps - 10.3125 Gbps (per channel)
- Maximum aggregate data rate: 41.25 Gps (4 x 10.3125Gbit/s)
- Copper link length up to 5m (passive limiting)
- High-Density QSFP 38-PIN Connector
- Power Supply :+3.3V
- Low power consumption: 0.02 W (typ.)
- I2C based two-wire serial interface for EEPROM signature which can be customized
- Temperature Range: 0~ 70 °C

STANDARDS COMPLIANCE

- IEEE 802.3ba
- SFF-8436
- QDR InfiniBand
- QSFP+ MSA
- RoHS Compliant

MECHANICAL DIMENSIONS

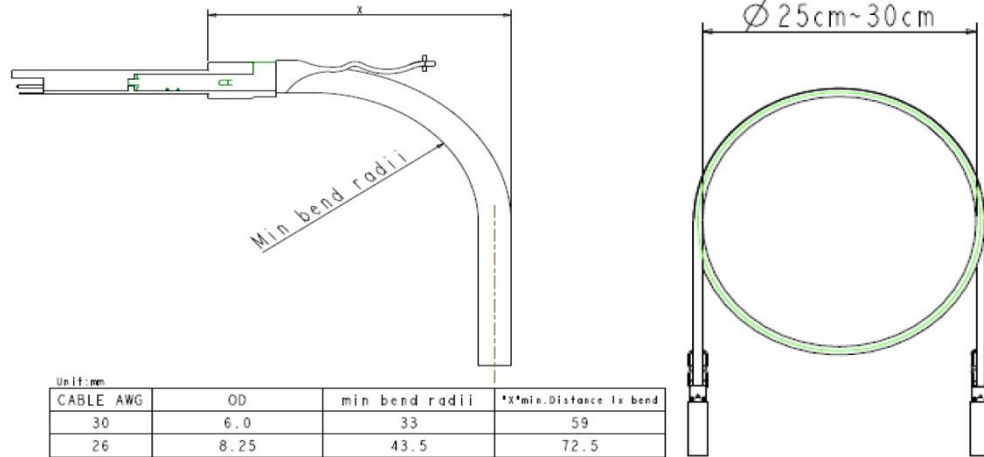

RECOMMENDED OPERATING CONDITIONS

Parameter	Symbol	Min	Typical	Max	Unit
Storage Ambient Temperature		-40		+85	°C
Operating Case Temperature	Tc	0		+70	°C
Power Supply Voltage	Vcc3	3.14	3.3	3.47	V
Power Dissipation	PD			0.02	W

QSFP+ Host Board Schematic for passive copper cables

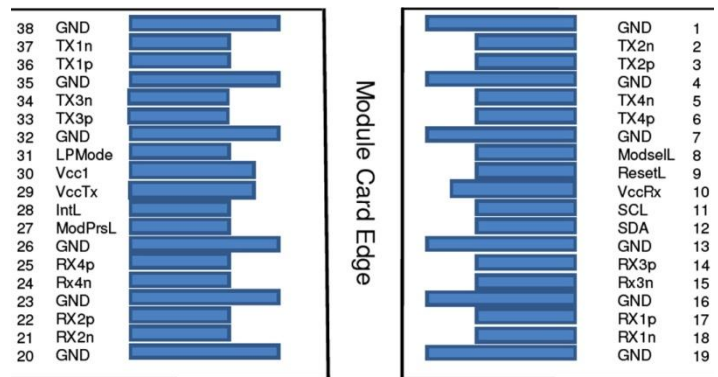
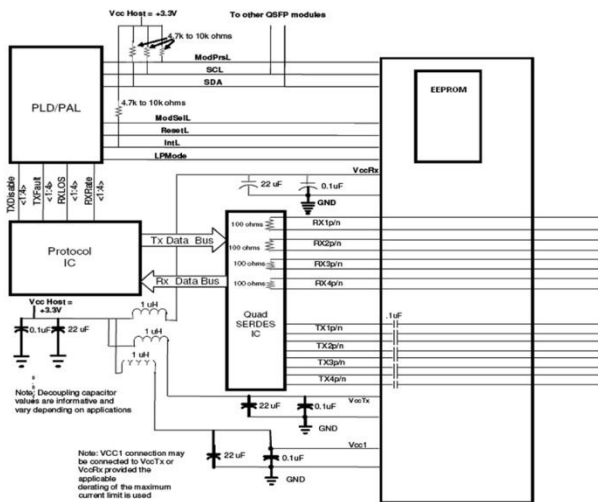

Top Side
Viewed From Top

Bottom Side
Viewed From Bottom

PIN DESCRIPTIONS

QSFP+ Copper Module



RECOMMENDED OPERATING CONDITIONS			
Logic	Symbol	Name/Description	Notes
	GND	Ground	1
CML-I	Tx2n	Transmitter Inverted Data Input	
CML-I	Tx2p	Transmitter Non-Inverted Data Input	
	GND	Ground	1
CML-I	Tx4n	Transmitter Inverted Data Input	
CML-I	Tx4p	Transmitter Non-Inverted Data Input	
	GND	Ground	1
LVTTTL-I	ModSelL	Module Select	
LVTTTL-I	ResetL	Module Reset	
	Vcc Rx	+3.3V Power Supply Receiver	2
LVC MOSI/O	SCL	2-wire serial interface clock	
LVC MOSI/O	SDA	2-wire serial interface data	
	GND	Ground	1
CML-O	Rx3p	Receiver Non-Inverted Data Output	
CML-O	Rx3n	Receiver Inverted Data Output	
	GND	Ground	1
CML-O	Rx1p	Receiver Non-Inverted Data Output	
CML-O	Rx1n	Receiver Inverted Data Output	
	GND	Ground	1
CML-O	Rx2p	Receiver Inverted Data Output	
CML-O	Rx2n	Receiver Non-Inverted Data Output	
	GND	Ground	1
CML-O	Rx4p	Receiver Inverted Data Output	
CML-O	Rx4n	Receiver Non-Inverted Data Output	
	GND	Ground	1
LVTTTL-O	ModPrsL	Module Present	
LVTTTL-O	IntL	Interrupt	
	Vcc Tx	+3.3V Power supply transmitter	2
	Vcc1	+3.3V Power supply	2
LVTTTL-I	LPMode	Low Power Mode	
	GND	Ground	1
CML-I	Tx3p	Transmitter Non-Inverted Data Input	
CML-I	Tx3n	Transmitter Inverted Data Input	
	GND	Ground	1
CML-I	Tx1p	Transmitter Non-Inverted Data Input	
CML-I	Tx1n	Transmitter Inverted Data Input	
	GND	Ground	1

Note 1: GND is the symbol for signal and supply (power) common for the QSFP+ module. All are common within the QSFP+ module and all module voltages are referenced to this potential unless otherwise noted. Connect these directly to the host board signal-common ground plane.

Note 2: Vcc Rx, Vcc1 and Vcc Tx are the receiver and transmitter power supplies and shall be applied concurrently. Requirements defined for the host side of the Host Edge Card Connector are listed in Table 6. Recommended host board power supply filtering is shown in Figure 4. Vcc Rx Vcc1 and Vcc Tx may be internally connected within the QSFP+ Module module in any combination. The connector pins are each rated for a maximum current of 500 mA.

40Gb/s QSFP+ to 4x SFP+ Breakout Active Optical Cable



STRUCTURE DIAGRAM & DESCRIPTION

QSFP+ to 4x SFP+ breakout active optical cable with full real-time digital diagnostic monitoring.

FEATURES

- 4 independent full-duplex channels
- Up to 11.2 Gb/s data rate per channel
- QSFP+ and SFP + MSA compliant
- Up to 100m transmission
- Operating case temperature: 0 to 70°C
- Single 3.3V power supply
- Maximum power consumption of 1.5W for QSFP+ terminal and 0.8W for each SFP+ terminal
- RoHS-6 compliant

APPLICATIONS

- 2 / 4 / 8G Fiber Channel
- Infiniband SDR/DDR/QDR
- 10/40G Ethernet



40Gb/s (QSFP + SR4) Optical Module



STRUCTURE DIAGRAM & DESCRIPTION

This product is a parallel 40Gb/s Quad Small Form-factor Pluggable (QSFP+) optical module. It provides increased port density and total system cost savings. The QSFP+ full-duplex optical module offers 4 independent transmit and receive channels, each capable of 10Gb/s operation for an aggregate data rate of 40Gb/s on 100 meters of OM3 multi-mode fiber. An optical fiber ribbon cable with an MTP/MPO connector can be plugged into the QSFP+ module receptacle. Proper alignment is ensured by the guide pins inside the receptacle. The cable usually cannot be twisted for proper channel to channel alignment. Electrical connection is achieved through a z-pluggable 38-pin IPASS® connector.

The module operates by a single +3.3V power supply. LVCMOS/LVTTL global control signals, such as Module Present, Reset, Interrupt and Low Power Mode, are available with the modules. A 2-wire serial interface is available to send and receive more complex control signals, and to receive digital diagnostic information. Individual channels can be addressed and unused channels can be shut down for maximum design flexibility. The product is designed with form factor, optical/electrical connection and digital diagnostic interface according to the QSFP+ Multi-Source-Agreement (MSA). It has been designed to meet the harshest external operating conditions including temperature, humidity and EMI interference. The module offers very high functionality and feature integration, accessible via a two-wire serial interface.

FEATURES

- 4 independent full-duplex channels
- Up to 11.2Gb/s data rate per channel
- MTP/MPO optical connector
- QSFP+ MSA compliant
- Digital diagnostic capabilities
- Up to 100m transmission on OM3 multi-mode ribbon fiber
- CML compatible electrical I/O
- Single +3.3V power supply
- Operating case temperature: 0~70oC
- XLPPi electric interface
- Maximum power consumption 1.5W
- RoHS-6 compliant

APPLICATIONS

- Rack to Rack
- Data Center
- Infiniband QDR, DDR and SDR
- 40G Ethernet

FUNCTIONAL DESCRIPTION

This product converts parallel electrical input signals into parallel optical signals, by a driven Vertical Cavity Surface Emitting Laser (VCSEL) array. The transmitter module accepts electrical input signals compatible with Common Mode Logic (CML) levels. All input data signals are differential and internally terminated. The receiver module converts parallel optical input signals via a photo detector array into parallel electrical output signals. The receiver module outputs electrical signals are also voltage compatible with Common Mode Logic (CML) levels. All data signals are differential and support a data rates up to 10Gb/s per channel. Figure 1 shows the functional block diagram of this product.

A single +3.3V power supply is required to power up the module. Both power supply pins VccTx and VccRx are internally connected and should be applied concurrently. As per MSA specifications the module offers 7 low speed hardware control pins (including the 2-wire serial interface): ModSelL, SCL, SDA, ResetL, LPMODE, ModPrsL and IntL. Module Select (ModSelL) is an input pin. When held low by the host, the module responds to 2-wire serial communication commands. The ModSelL allows the use of multiple QSFP+ modules on a single 2-wire interface bus – individual ModSelL lines for each QSFP+ module must be used. Serial Clock (SCL) and Serial Data (SDA) are required for the 2-wire serial bus communication interface and enable the host to access the QSFP+ memory map. The ResetL pin enables a complete module reset, returning module settings to their default state, when a low level on the ResetL pin is held for longer than the minimum pulse length. During the execution of a reset the host shall disregard all status bits until the module indicates a completion of the reset interrupt. The module indicates this by posting an IntL (Interrupt) signal with the Data_Not_Ready bit negated in the memory map. Note that on power up (including hot insertion) the module should post this completion of reset interrupt without requiring a reset. Low Power Mode (LPMODE) pin is used to set the maximum power consumption for the module in order to protect hosts that are not capable of cooling higher power modules, should such modules be accidentally inserted. Module Present (ModPrsL) is a signal local to the host board which, in the absence of a module, is normally pulled up to the host Vcc. When a module is inserted into the connector, it completes the path to ground through a resistor on the host board and asserts the signal. ModPrsL then indicates a module is present by setting ModPrsL to a “Low” state. Interrupt (IntL) is an output pin. Low indicates a possible module operational fault or a status critical to the host system. The host identifies the source of the interrupt using the 2-wire serial interface. The IntL pin is an open collector output and must be pulled to the Host Vcc voltage on the Host board.

Transceiver Block Diagram

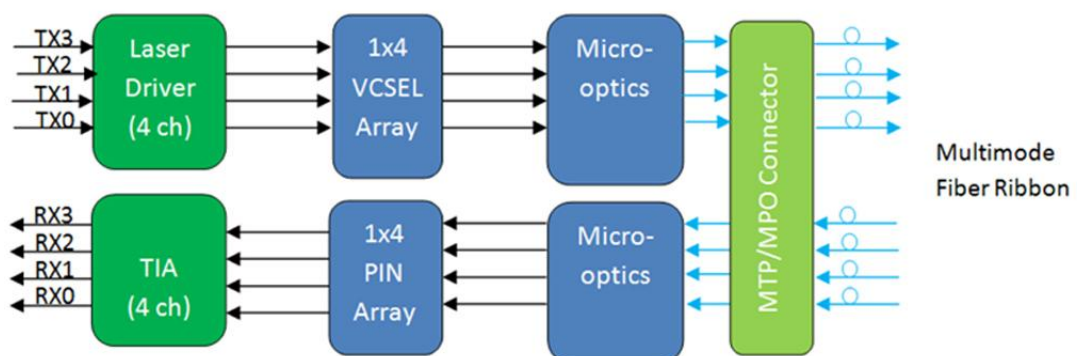

4, 8, 16, 18 Channels CWDM OADM Module



FEATURES

- Low insertion loss
- Wide pass band
- High channel isolation
- High stability and reliability
- Epoxy free on optical path

APPLICATIONS

- Line monitoring
- WDM network
- Telecommunication
- Cellular applications
- Fibre optical amplifier
- Access network

PERFORMANCE SPECIFICATION

Parameter	4 Channels		8 Channels		16 Channels		
	Mux	Demux	Mux	Demux	Mux	Demux	
Channel Wavelength (nm)	1270~1610 or 1271~1611						
Channel Spacing (nm)	20						
Channel Passband (@-0.5dB bandwidth) (nm)	±7.5/±6.5						
Insertion Loss (dB)	≤1.5		≤2.5		≤3.5		
Channel Uniformity (dB)	≤0.6		≤1.0		≤1.5		
Channel Ripple (dB)	<0.3						
	Adjacent	N/A	>30	N/A	>30	N/A	>30
	Non-adjacent	N/A	>40	N/A	>40	N/A	>40
Insertion Loss Temperature Sensivity (dB/°C)	<0.005						
Wavelength Temperature Shifting (nm/°C)	<0.002						
Polarization Dependent Loss (dB)	<0.1						
Polarization Mode Dispersion (ps)	<0.1						
Directivity (dB)	>50						
Return Loss(dB)	>45						
Maximum Power Handling (mW)	300						
Operating Temperature (°C)	-5~+75						
Storage Temperature (°C)	-40~+85						
Package Dimension (mm)	L100 x W80 x H10			L140 x W114 x H18 L120 x W80 x H18			



Specifications are for devices without connector. Specifications may change without notice.

ORDERING INFORMATION

CWDM	<input type="checkbox"/>	<input type="checkbox"/> <input type="checkbox"/>	<input type="checkbox"/>	<input type="checkbox"/> <input type="checkbox"/>	<input type="checkbox"/>	<input type="checkbox"/>	<input type="checkbox"/>
	Channel Spacing	Number of Channels	Configuration	1st Channel	Fiber Type	Fiber Length	Connector
	C=CWDM Grid	04=4Channel 08=8Channel 16=16Channel 18=18Channel N=N Channel	M=Mux D=Demux O=OADM	27=1270nm 47=1470nm 49=1490nm 61=1610nm	0=Bare fiber 1=900µm loose tube 2=2mm cable 3=3mm cable	1=1m 2=2m S=Specify	0=None 1=FC/APC 2=FC/UPC 3=SC/APC 4=SC/UPC 5=LC/APC 6=LC/UPC 7=ST S=Specify

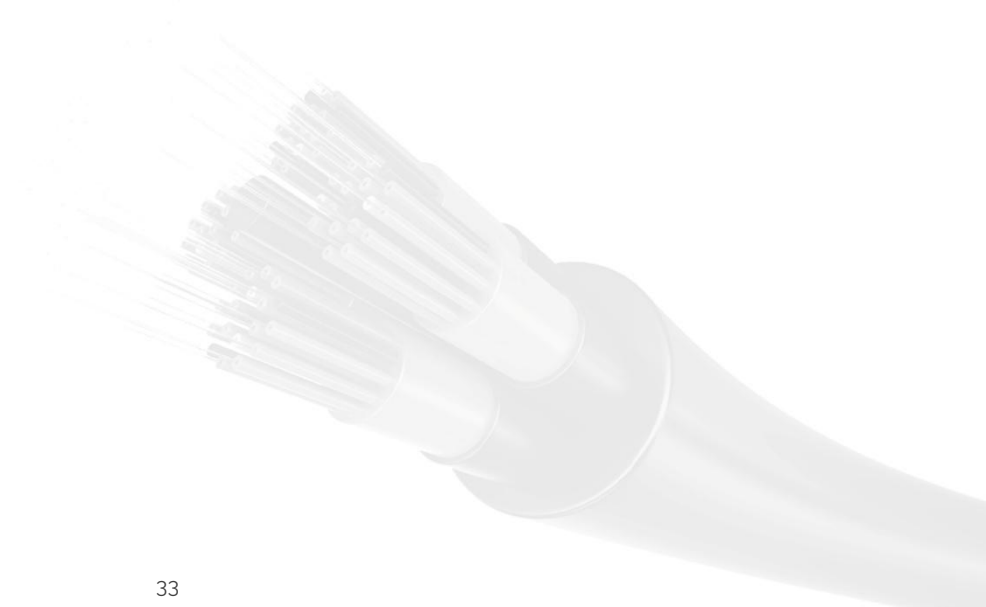
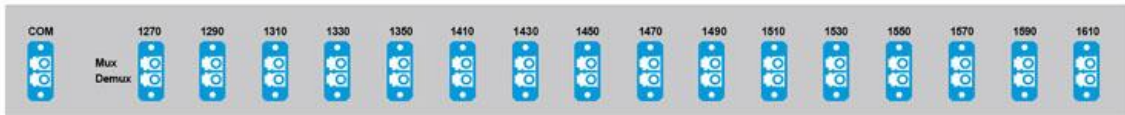
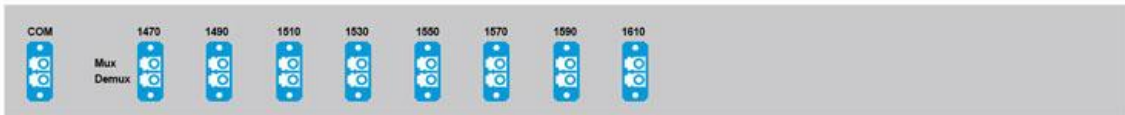

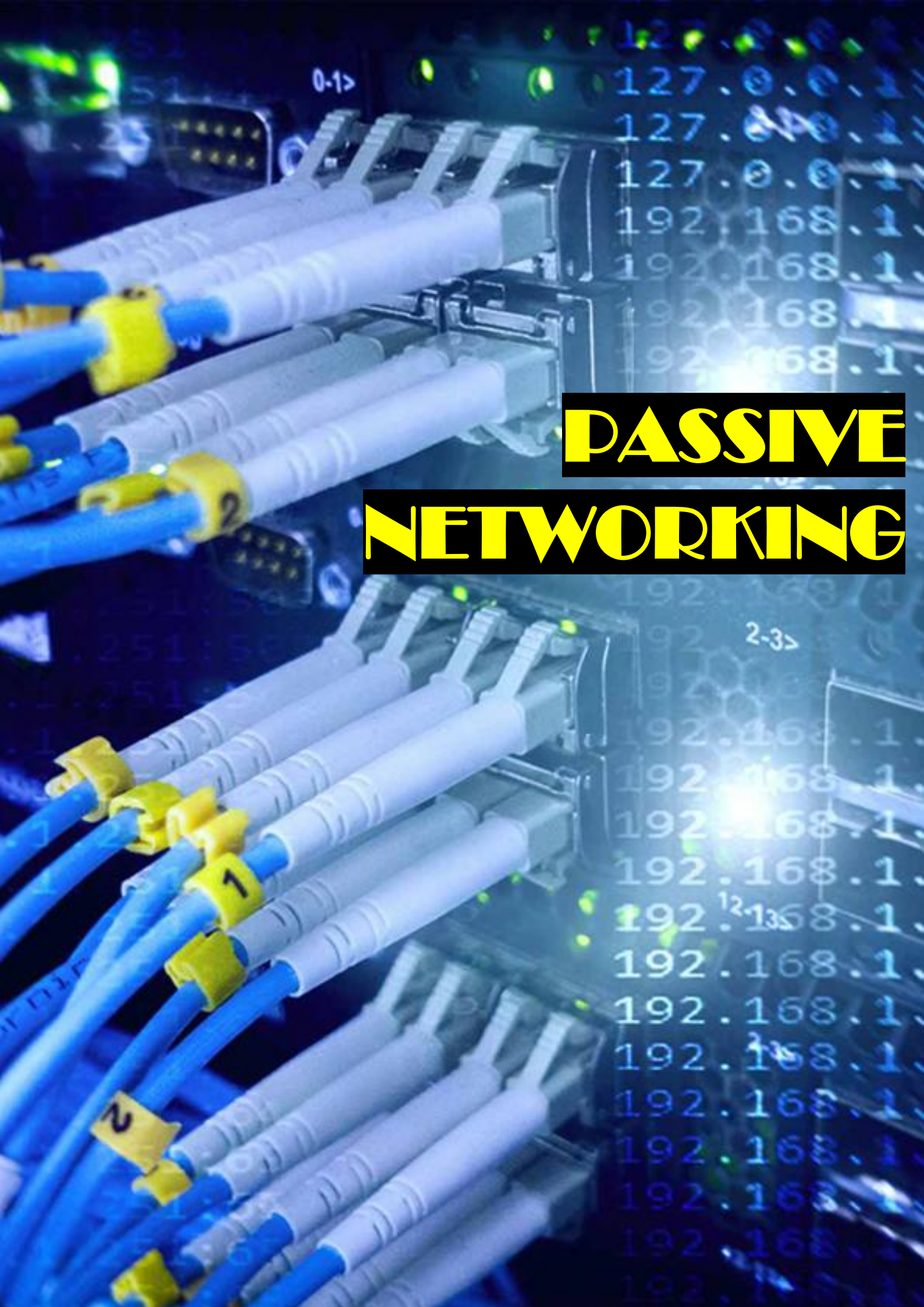

PASSIVE

NETWORKING

Bespoke Adapters

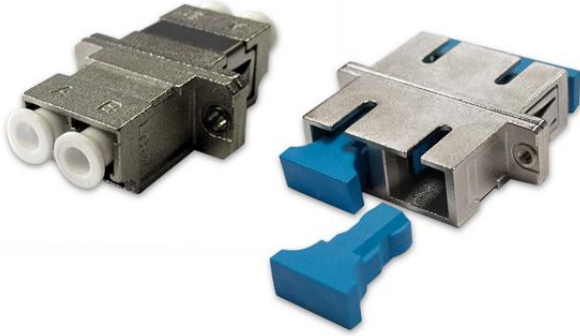

METAL ADAPTERS

We understand each customer might require unique specifications for their networking needs.

We are happy to offer bespoke adapters in all configurations using different materials, such as metal for increased strength and durability.

- LC Duplex and SC Duplex Metal Adapters

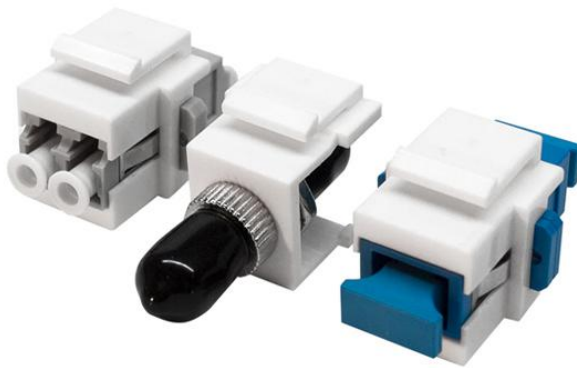

KEYSTONE ADAPTERS

Our fibre keystone modules support optical applications in bringing fibre to the desktop for both multimode and singlemode fibre installations.

They are designed to snap directly into standard keystone faceplates, inserts, surface mount boxes and blank patch panels.

- LC, ST and SC varieties shown

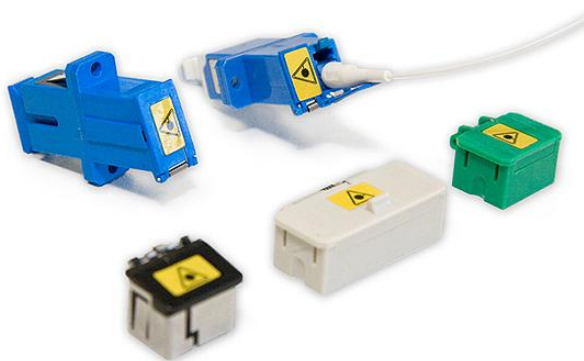

SHUTTERED ADAPTERS

Our shuttered adapter range provides a combination of safety features for FTTH applications & telecommunication networks. The shuttered design ensures the adapter remains dust free, increasing reliability and performance.

- SC APC Shuttered Adapter



Bespoke Connectors & Adapters

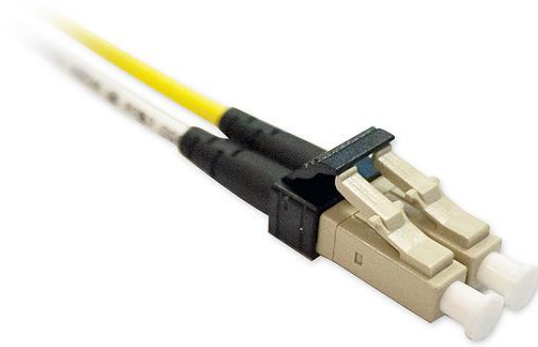

MINI-LC CONNECTOR

Mini-LC duplex connectors use industry standard LC connectors with a reduced centreline pitch from 6.25mm to 5.25mm, achieved with a specially designed duplex clip. Mini-LC duplex connectors are available in singlemode and multimode versions with 2mm or 3mm cable.



LC LOOPBACK CONNECTOR MODULE

Loopback modules are designed for the purpose of testing the transmission capability and receiver sensitivity in a network. It is a simple and effective testing solution available in our complete duplex range of connectors.

How it is used?

One connector is plugged into the output port, while the other is plugged into the input port of the equipment.

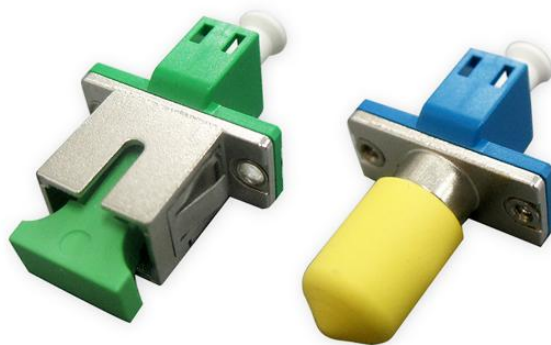

HYBRID ADAPTERS

Hybrid adapters provide a solution for applications where two different connector types are used. They are available with a variety of connector options: choice of housing material, simplex or duplex configurations and singlemode or multimode fibre types.

- LC-SC APC Simplex/LC-ST Singlemode Simplex Hybrid Adapters

E2 / UPC - E2 / E2A Connector / Adapter

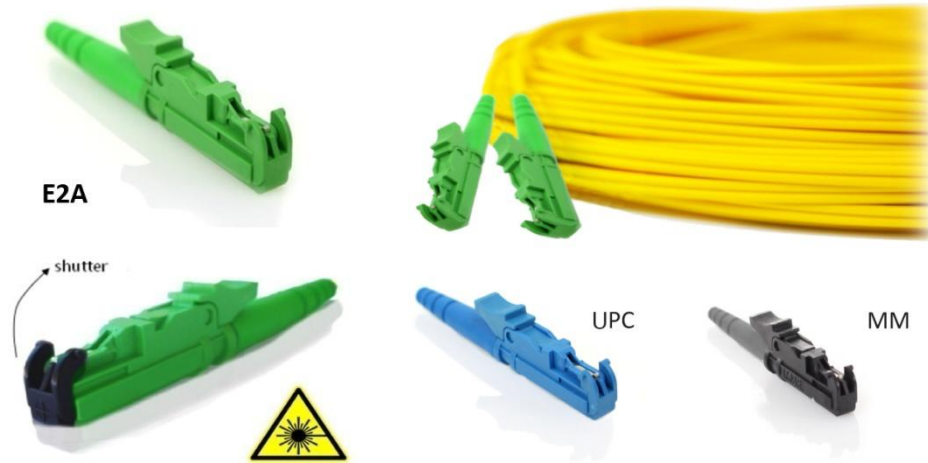

STRUCTURE DIAGRAM & DESCRIPTION

Our E2/E2A patchcord and pigtail connectors feature a spring-loaded shutter, which fully protects the ferrule from dust and scratches. The shutter closes automatically when the connector is disengaged, thus blocking impurities. The E2 or E2A connector is compliant with European (EN 186270) and International (IEC 61754-15) standards.

FEATURES

- E2 and E2A polishing options
- Simplex and Duplex configuration
- Easy and safe insertion and removal
- Robust construction
- Excellent choice for singlemode applications
- Colours available: black, blue and green

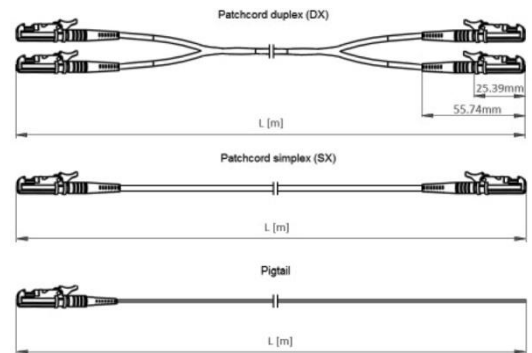

EXAMPLES OF PATCHCORDS AND PIGTAILS



CONNECTOR PERFORMANCE - SINGLEMODE

Insertion Loss	Max. 0.3dB; Typical 0.2dB
Return Loss	UPC > 50dB Typical 55dB E2A > 60dB Typical 65dB

CONNECTOR PERFORMANCE - MULTIMODE

Insertion Loss	Max. 0.5dB; Typical 0.3dB
----------------	---------------------------

FC Connector/Adapter



Multimode FC Connector

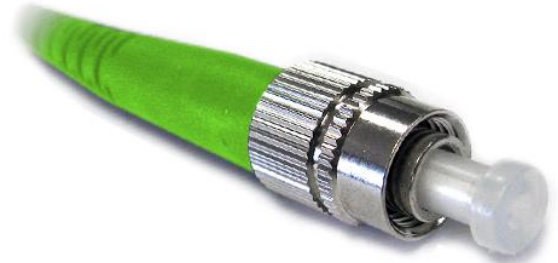

FC-APC Connector

STRUCTURE DIAGRAM & DESCRIPTION

Our FC Connector is a threaded cylindrical connector. It is designed to hold secure and remain stable in high-vibration environments and is used in most areas of a fibre network. It is constructed from nickel-plated metal and features a keyway for correct alignment.

FEATURES

- UPC and APC polishing options
- Simplex configuration
- Bayonet style spring
- Stainless construction
- 900µm, 2mm and 3mm diameter boot options



FC Adapter

2MM & 3MM CONNECTOR MATERIALS

Flange	Brass, Nickel Plated
Ferrule	Ceramic
Dust cap	Plastic
Boot	Plastic
Ring	Brass, Nickel Plated
Crimp Eyelet	AL
Stopper	Brass, Nickel Plated
Spring	Stainless
Housing	Plastic
Coupling	Plastic

900µm CONNECTOR MATERIALS

Flange	Brass, Nickel Plated
Ferrule	Ceramic
Dust cap	Plastic
Boot	Plastic
Stopper	Brass, Nickel Plated
Spring	Stainless
Housing	Plastic
Coupling	Plastic
-	-
-	-

Harsh Environment LC Connector Assembly



STRUCTURE DIAGRAM & DESCRIPTION

IP67 water-resistant LC connector assemblies are an important solution for harsh environments. They offer increased protection from contamination and moisture, with the addition of mechanical stability, anti-vibration and temperature resistance.

Authentication - RoHS

FEATURES

- Standard LC duplex connector which can be connected with standard LC duplex adaptor
- Available singlemode and multimode
- IP67 protection, salt-mist proof, humidity proof, dust proof
- Low insertion/return loss with a steady optical signal
- Lightweight, waterproof, dustproof, moisture proof, with a hard metal housing

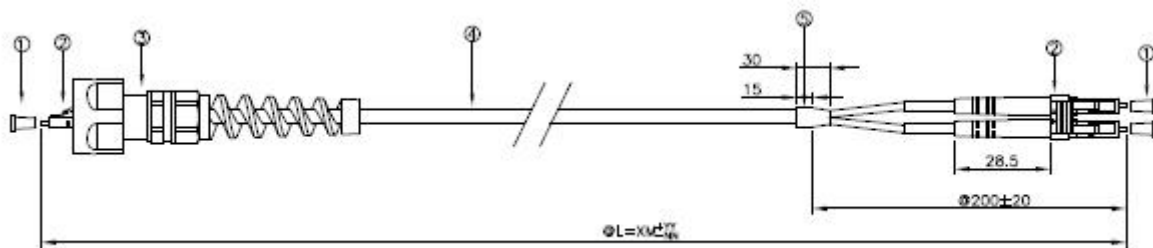

SPECIFICATIONS

Insertion Loss	$\leq 0.3\text{dB}$
Mechanical life	500 cycles
Working temperature	$-40^{\circ}\text{C} \sim +70^{\circ}\text{C}$
Storage temperature	$-40^{\circ}\text{C} \sim +70^{\circ}\text{C}$
Operating temperature	$-10^{\circ}\text{C} \sim +50^{\circ}\text{C}$
Protection Level	IP67
Tensile Data	(between junction and fibre cable) $\geq 180\text{N}$
UV resistant outer housing	UL 746C
Flame retardant outer housing	UL94 V-0

LC Connector/Adapter



Duplex Multimode Connector



Simplex Singlemode and APC

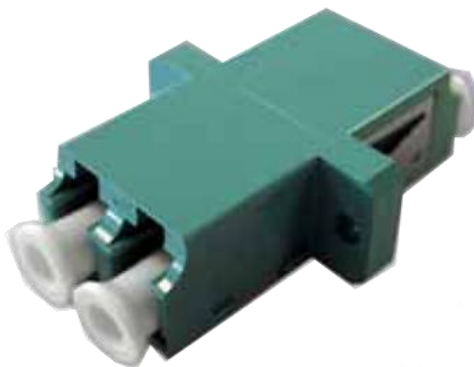

Duplex Multimode Aqua Adapter

The LC (Lucent Connector) is a small form-factor connector, characterised by its small size, 1.25mm ferrule and insertion clip. Its 1.25mm ferrule is half the size of the ST connector and is often used in singlemode applications due to its fantastic performance.

FEATURES

- PC, UPC and APC polishing options
- Simplex and Duplex configuration
- Easy and safe insertion and removal
- Robust construction
- Excellent choice for singlemode applications
- Colours available: beige, blue and green
- 900µm, 2mm and 3mm diameter boot

CONNECTOR SPECIFICATIONS

Temp. Cycling	-40 to +75°C, 40 cycles; =0.2dB Change
High Temp.	70°C for 96 hours; < 0.4dB Change
Damp Heat	40°C at 93% RH, 96 hours; < 0.4dB Change
Vibration	10-55 Hz, 1.5mm P to P; < 0.2dB Change
Mating Durability	500 mating cycles; < 0.2dB Change
Operating Temp.	-40°C to +85°C

CONNECTOR PERFORMANCE - SINGLEMODE

Insertion Loss	Max. 0.3dB; Typical 0.2dB
Return Loss	UPC > 50dB Typical 55dB APC > 60dB Typical 65dB

CONNECTOR PERFORMANCE - MULTIMODE

Insertion Loss	Max. 0.5dB; Typical 0.3dB
----------------	---------------------------

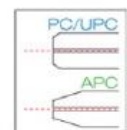
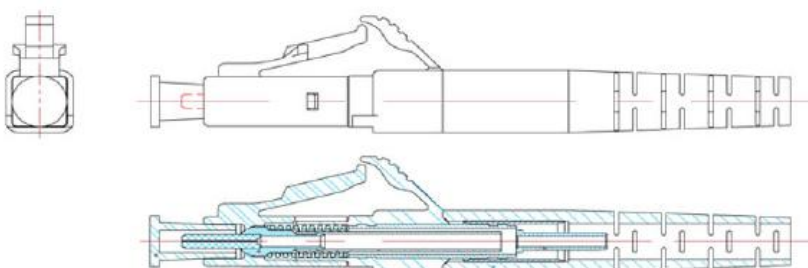

LC Connector SM and MM 3.0mm boot style

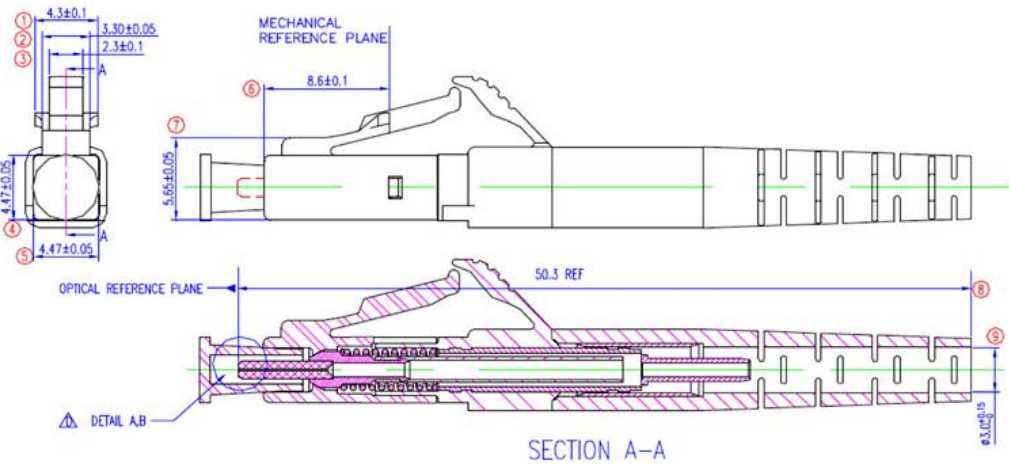

LC Connector SM and MM 2.0mm boot duplex style

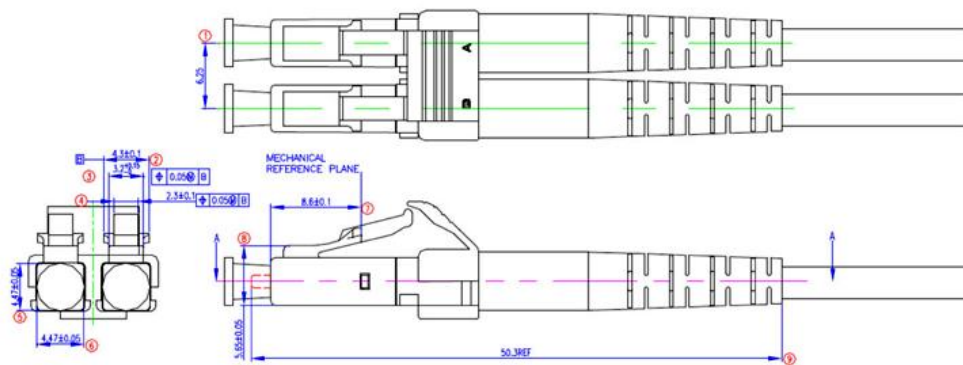

LC Connector SM and MM 3.0mm boot duplex style

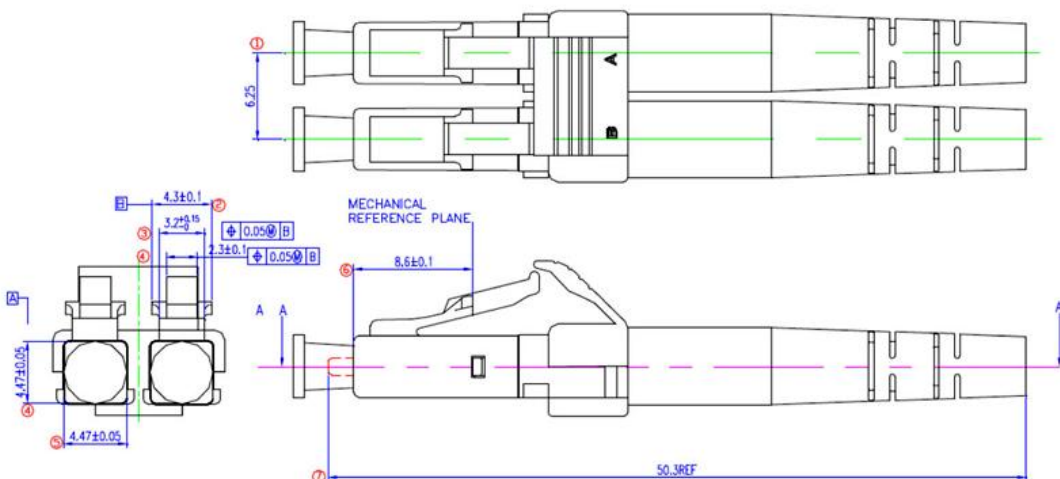

LC Connector SM and MM 0.9mm boot style

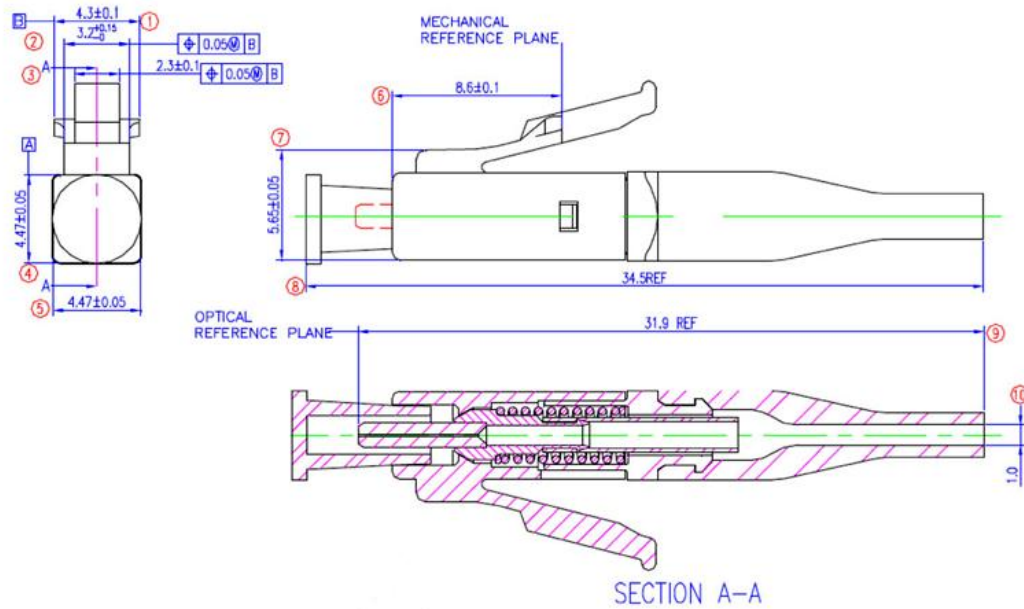

LC Connector SM and MM 2.0mm boot style

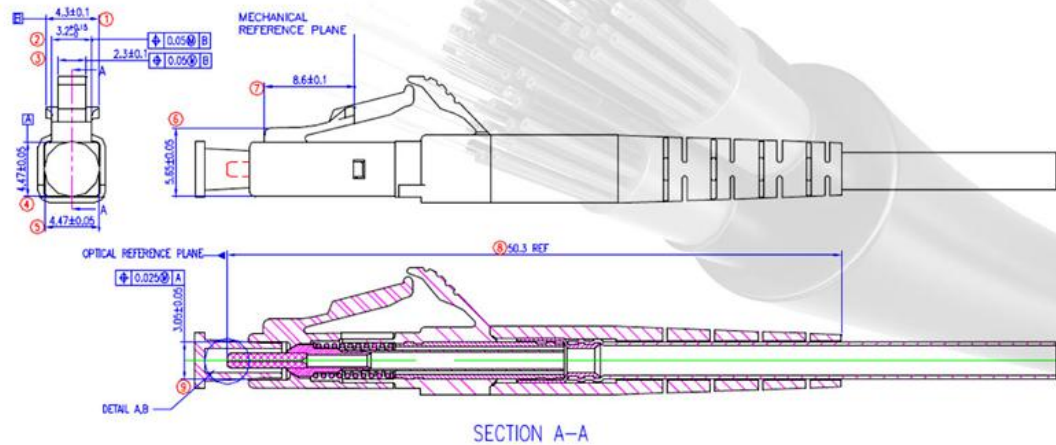

Ordering Information

MODE	
OM1	OM1
OM2	OM2
OM3	OM3
OM4	OM4
OS2	OS2
G657A1	7A
G657A2	7A2

CONSTRUCTION TYPE	
LOOSE TUBE	LT
TIGHT BUFFERED	TB
STEEL TAPE ARMoured	STA
BREAKOUT	BO
STEEL WIRE ARMOUR	SWA

NO. OF FIBRES	
1 Fibre	1
2 Fibre	2
4 Fibre	4
8 Fibre	8
12 Fibre	12
16 Fibre	16
24 Fibre	24
48 Fibre	48
96 Fibre	96
144 Fibre	144
288 Fibre	288

JACKET	
Low Smoke Zero Hallogen	LS
Poly Ethylene	PE

Sample Part Number

OM1	TB	24	LS
-----	----	----	----

OM1TB24-LS
OM1 Loose Tube Cable 24 Fibres Low Smoke Hallogen

ESTIMATED CABLE WEIGHTS CHART KG/KM							
FIBRE COUNTS	TB	LT	STA	SWA	FLAT	DUPLEX	SIMPLEX
2	19	53	88	180	27	9	7.5
4	22	53	88	180	X	X	X
6	29	53	88	180	X	X	X
8	37	53	88	180	X	X	X
12	49	53	88	180	X	X	X
24	57	60	88	180	X	X	X

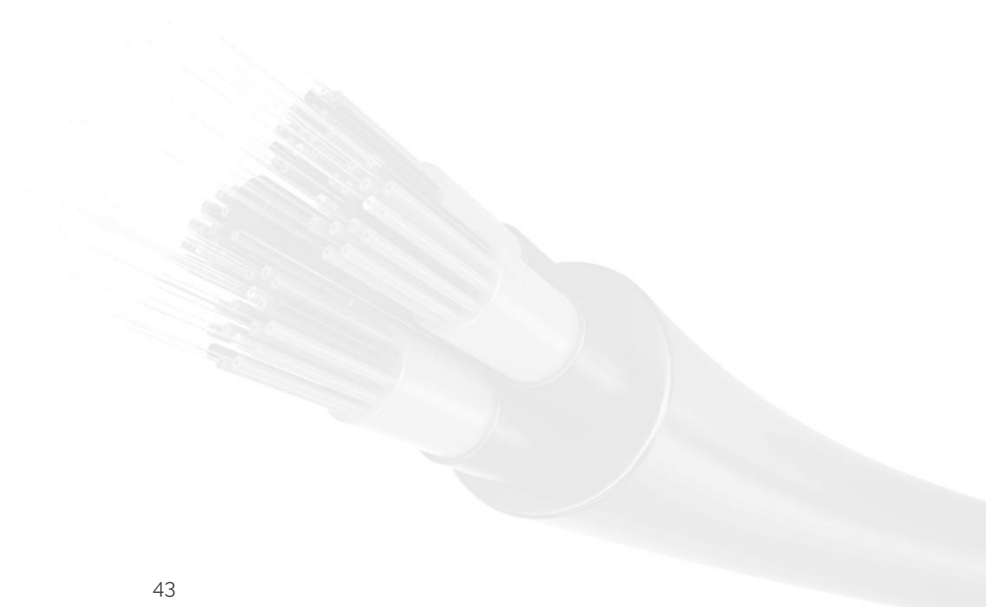

LC Quad Adapters

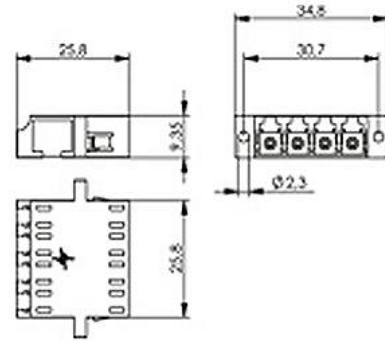
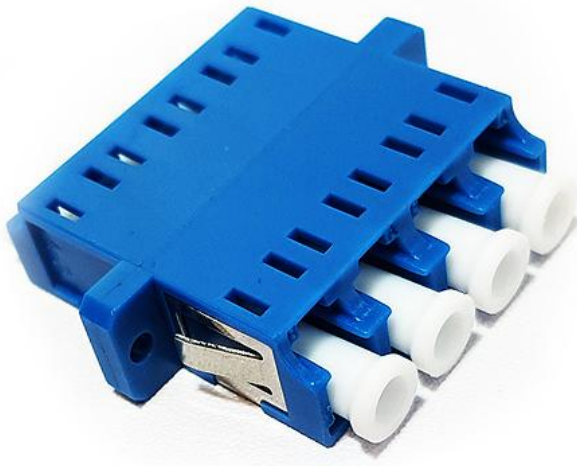

STRUCTURE DIAGRAM & DESCRIPTION

Durable, precise and reliable: ICL's fibre optic adapters coupling sleeves are made of zirconia ceramics, exceeding the specifications of the relevant international standards.

FEATURES

- Description: LC Quad Adaptor, multimode, singlemode, ceramic sleeve, plastic housing
- Installation: Snap-in or screw mounted
- Mounting dim.: SC Duplex aperture
- Housing Colour: Blue, Aqua, Beige, Violet, Green

PERFORMANCE CHARACTERISTICS

- For singlemode and multimode applications

MECHANICAL CHARACTERISTICS

- IEC 61300-3-4 - Insertion Loss "typ" 0.1dB - Ceramic
- IEC 61300-2-2 - Mating Durability 500 cycles
- IEC 61754-13 - Receptacle Retention Force 12N – 2.5N
- IEC 61300-2-22 - Operating Temperature -25°C to +70°C (12-cycles)

Material: adaptor split sleeve	Zirconia ceramic
Material: adaptor housing	Thermoplastic, flame retardant, non halogen Multimode: Beige, Aqua, Violet; Singlemode: Blue;
Colour: adaptor housing	Singlemode APC: Green

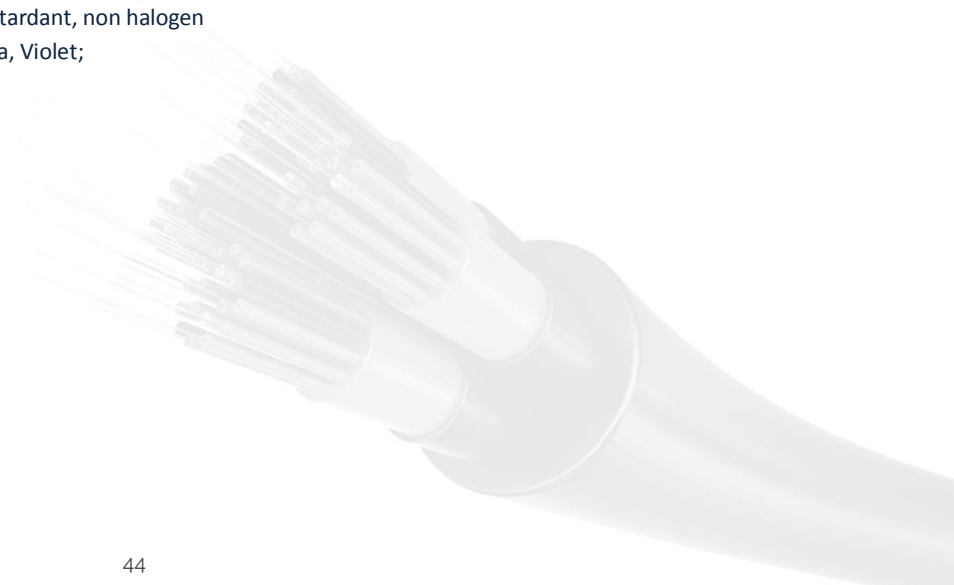

MTRJ System

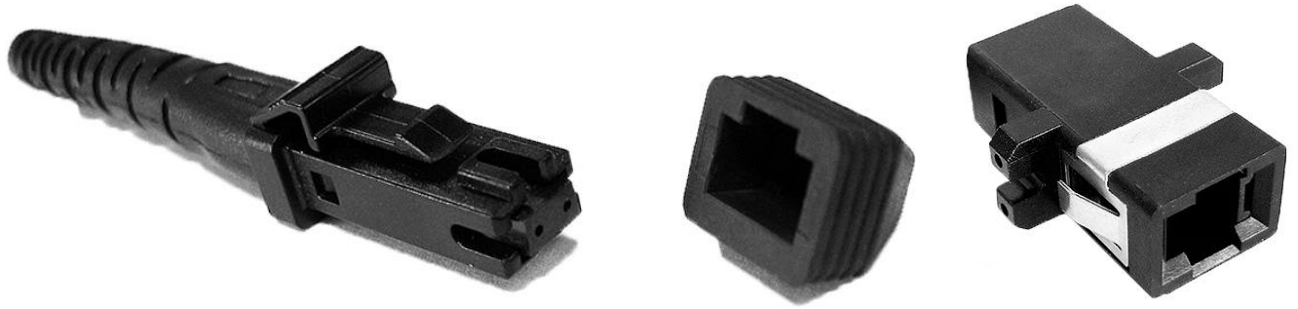

STRUCTURE DIAGRAM & DESCRIPTION

The ICL MTRJ (Mechanical Transfer Registered Jack) is a popular small-form connector. It features two fibres mated together that align with the adapter with the help of keyway orientation and are secured with a clip. Popularised from its low cost and small size.

FEATURES

- PC, UPC and APC polishing options
- Simplex and Duplex configuration
- Bayonet style spring
- Stainless construction

2mm, 3mm Connector Materials

Flange	Brass, Nickel Plated
Ferrule	Ceramic
Dust cap	Plastic
Boot	Plastic
Ring	Brass, Nickel Plated
Crimp Eyelet	AL
Stopper	Brass, Nickel Plated
Spring	Stainless
Housing	Plastic
Coupling	Plastic

900µm Connector Materials

Flange	Brass, Nickel Plated
Ferrule	Ceramic
Dust cap	Plastic
Boot	Plastic
Ring	-
Crimp Eyelet	-
Stopper	Brass, Nickel Plated
Spring	Stainless
Housing	Plastic
Coupling	Plastic

MU Connectors

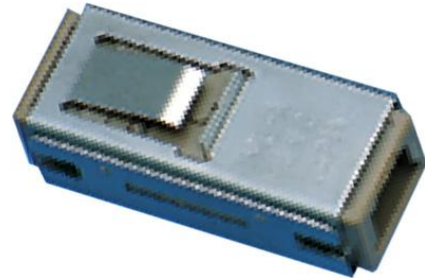

FEATURES

- Optimum optical performance through Adamant high quality ferrules
- Wide selection of ferrules
- Small form factor and high density applications
- Ferrule inspection data sheet included with all shipments

APPEARANCE

Fiber Jacket ϕ 0.9mm

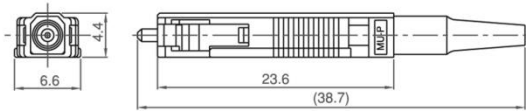

Fiber Jacket ϕ 2.0mm

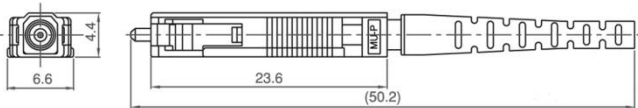

MUJ Style Plug Fiber (Jacket ϕ 0.9mm)

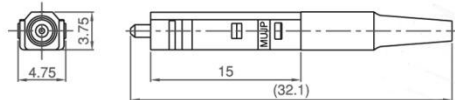

Adapter

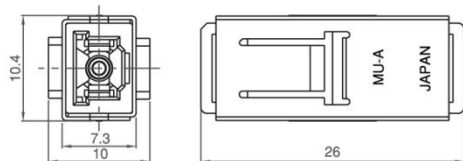

SPECIFICATIONS

- IEC 61754-6: Type MU connector
- Telcordia GR-326-CORE
- SM (9/125) , MM (50/125, 62.5/125)
- $\leq 0.1\text{dB}$ (SM) $\leq 0.1\text{dB}$ (MM)
- $\leq 0.2\text{dB}$ $\leq 0.1\text{dB}$ (APC)
- $\geq 55\text{dB}$ (SM) , $\geq 70\text{dB}$ (APC) , $\geq 30\text{dB}$ (MM)
- $-40^{\circ}\text{C} \sim +85^{\circ}\text{C}$
- $\leq 0.3\text{dB}$ ($-40^{\circ}\text{C} \sim +85^{\circ}\text{C}$)
- $\leq 0.2\text{dB}$ (500回)
- Based on IEC 61754-6: Type MU connector
- Telcordia GR-326-CORE tested
- Fiber types : SM (9/125) , MM (50/125, 62.5/125)
- Insertion Loss* : [Connector] $\leq 0.1\text{dB}$ (SM) $\leq 0.1\text{dB}$ (MM)
- [Adapter] $\leq 0.2\text{dB}$ $\leq 0.1\text{dB}$ (APC)
- Return Loss : $\geq 55\text{dB}$ (SM) , $\geq 70\text{dB}$ (APC) , $\geq 30\text{dB}$ (MM)
- Operation Temperature : $-40^{\circ}\text{C} \sim +85^{\circ}\text{C}$
- Temperature Stability: $\leq 0.3\text{dB}$ ($-40^{\circ}\text{C} \sim +85^{\circ}\text{C}$)
- Mating Durability: $\leq 0.2\text{dB}$ (500times)
- Housing Color : Brown (SM) , Green (APC) , Beige (MM)

*Tested against Master Connector

SC Connector/Adapter

The SC (Subscriber Connector) is a low cost and durable snap-in, push-pull style connector, commonly utilized in newer network applications. It is characterised by its square housing, 2.5mm ferrule and features a keyway for correct insertion purposes.

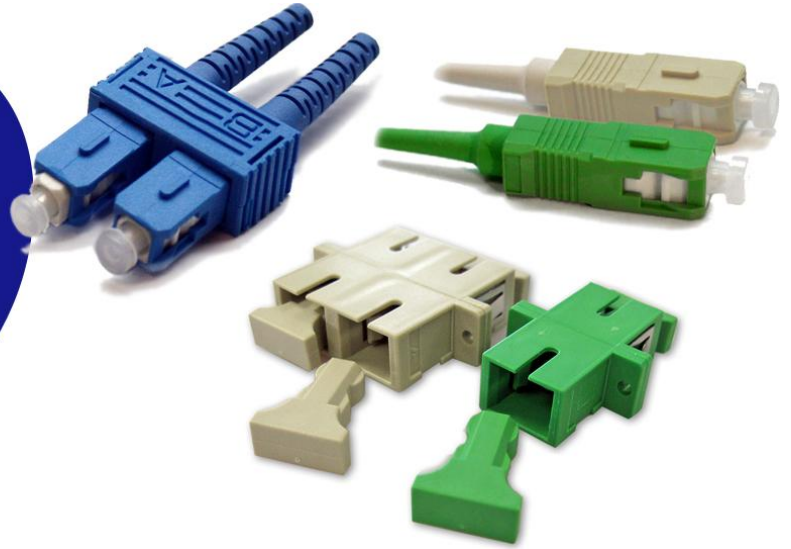

FEATURES	
•	PC, UPC and APC polishing options
•	Simplex and Duplex configuration
•	Easy and safe insertion and removal
•	Robust construction
•	Excellent choice for singlemode applications
•	Colours available: beige, blue and green
•	900µm, 2mm and 3mm diameter boots

SPECIFICATIONS	
Temp. Cycling	-40°C to +75°C, 40 cycles; =0.2dB Change
High Temp.	70°C for 96 hours; < 0.4dB Change
Damp Heat	40°C at 93% RH, 96 hours; < 0.4dB Change
Vibration	10-55 Hz, 1.5mm P to P; < 0.2dB Change
Mating Durability	500 mating cycles; < 0.2dB Change
Operating Temp.	-40°C to +85°C

SINGLEMODE PERFORMANCE	
Insertion Loss	Max. 0.3dB; Typical 0.2dB
Return Loss	UPC > 50dB Typical 55dB APC > 60dB Typical 65dB

MULTIMODE PERFORMANCE	
Insertion Loss	Max. 0.3dB; Typical 0.2dB

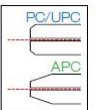
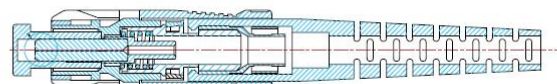
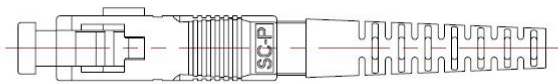

Secure Lock LC Connectors



STRUCTURE DIAGRAM & DESCRIPTION

Secure lock LC connectors offer mechanical network security for organizations desiring to segregate networks for privacy or security concerns. The unique adaptor locking mechanism is designed for preventing accidental fibre disconnection of important channel links. The adaptor housing is moulded in one piece, giving enhanced precision, structure and reliable performance. Used with any secure lock LC connector.

FEATURES

- Prevents unauthorized changes - ICL's secure lock LC connectors are designed to prevent unauthorized or inadvertent changes to cabling networks in highly sensitive applications (such as data centers, telecom rooms and enterprise networks including financial, educational, IT and military networks) where multiple physical layer access classifications are critical
- Secure Lock connectors offer a unique tamper proof solution - ICL's unique 'tamper proof' Secure Lock LC connectivity solution is compatible and can be fitted to any industry-standard LC ports in active network equipment, patch panels and customer premise equipment. ICL's Secure Lock LC solution is available in pigtail, patchcord and multi-fiber cable formats.
- The efficient ICL Secure Lock LC design accommodates high density patching applications. ICL Secure Lock products are ideal to secure physical layer control in military and federal networking, video broadcast and highly sensitive data-center markets.
- Easy extraction with a matching colour-coded tool - the locking Secure Lock LC connectors can only be unplugged using a matching colour-coded extraction tool. These keyed tools allow automatic de-latching of the Secure Lock LC connector from the port, limiting physical disturbance of adjacent live circuit connections. Access to empty or unassigned ports can be prevented with the use of similarly keyed colour coded Secure Lock LC Port blockers.
- The SecureLock LC extraction tools allow for easy manual connector removal even from high density patch panels and are colour coded to match the connector key type. The connectors plug into both duplex and quad adaptors.
- Complimenting the Secure Lock LC connectors, ICL also provides Secure Lock LC locking port plugs acting as 'locking dust caps' enabling empty LC ports to be locked out, preventing the unauthorized insertion of a cable assembly or connector. The port plugs can be disconnected in the same way as the Secure Lock LC connector simply by using the appropriate keyed extraction tool.

TECHNICAL PARAMETERS

SPECIFICATIONS

Insertion loss	0.1dB Typical for SM UPC, SM APC, MM PC
Return loss	55dB for SM UPC, 65dB for SM APC
Lock Key Options	4 Key configuration in 4 colours Red, Yellow, Black and White
Boot / Cable option	3mm, 2mm boot Flex angle boot also available
Operating Temperature	-40°C to +75°C
Mechanical requirement	To meet and exceed GR-326 Core Issue 4

Secure Lock LC Connectors

EXTENDED INFORMATION

- True locked keyed connector security
- Multiple key configurations of access control and tamper-proofing
- Compatible with all industry standard ports
- Industry standard colour coding of housings for easy identification and administration
- Blockers available for 'protecting' unused LC ports

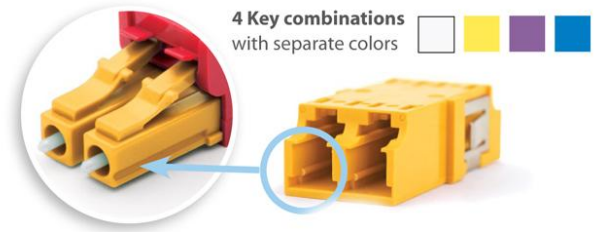

APPLICATIONS

- FTTX bi-directional networks
- Telecom rooms & ODF's
- Secure military IT networks
- Commercial enterprise networks
- Datacenters
- Customer premise connections
- Test labs

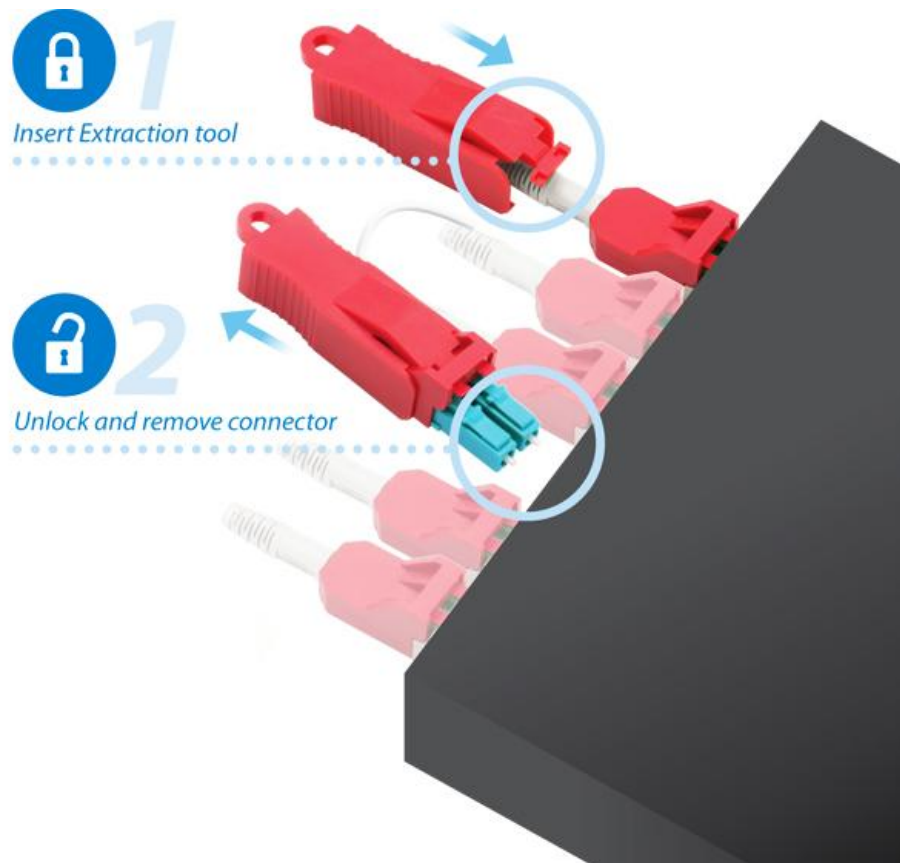

ST Connector / Adapter



Multimode ST Connector



Singlemode ST Connector



STRUCTURE DIAGRAM & DESCRIPTION

The ICL ST (Straight Tip) is a Quick release, bayonet style connector. Its cylindrical design features a keyed ferrule for correct insertion purposes, and a metal spring to ensure fit into the keyed ST screw-in adapter. A twist bayonet ensures a secure connection.

FEATURES

- PC, UPC and APC polishing options
- Simplex configuration
- Bayonet style spring
- Stainless construction
- 900 um, 2mm and 3mm diameter boot

CONNECTOR SPECIFICATIONS

Temp. Cycling	-40 to +75°C, 40 cycles; = 0.2dB Change
High Temp.	70°C for 96 hours; < 0.4dB Change
Damp Heat	40°C at 93% RH, 96 hours; < 0.4dB Change
Vibration	10-55 Hz, 1.5mm P to P; < 0.2dB Change
Mating Durability	500 mating cycles; < 0.2dB Change
Operating Temp.	-40°C to +85°C

CONNECTOR PERFORMANCE - SINGLE MODE

Insertion Loss	Max. 0.3dB; Typical 0.2dB
Return Loss	UPC > 50dB Typical 55dB APC > 60dB Typical 65dB

CONNECTOR PERFORMANCE – MULTI MODE

Insertion Loss	Max. 0.5dB; Typical 0.3dB
----------------	---------------------------

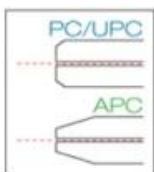
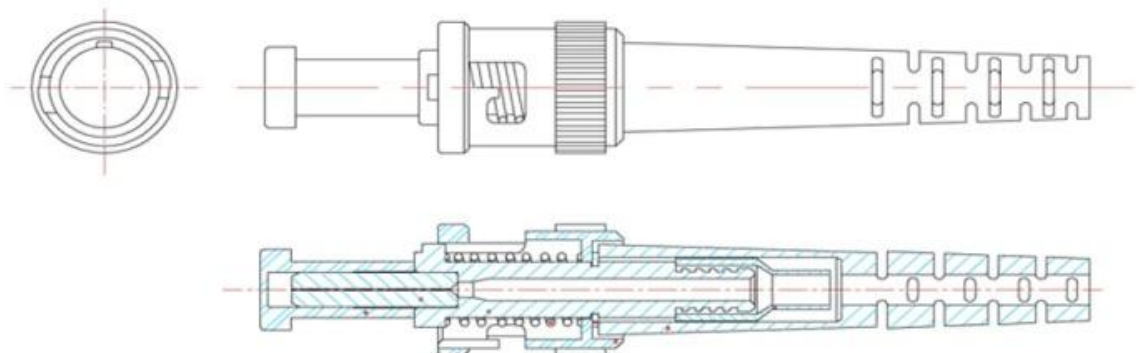

LC Field Installable Connector (FIC)

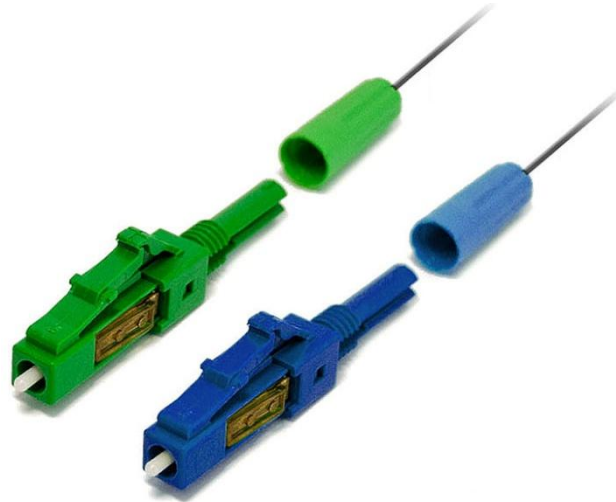

STRUCTURE DIAGRAM & DESCRIPTION

A LC type FIC is a pre-polished and pre-assembled connector which holds a fibre in place and can be installed within 2 minutes. The LC type is a small design with great details and high technology. All the parts are made from Ultem™ material to withstand high temperature and external shocks. It is available in several configurations to suit different singlemode and multimode applications. The APC connector is designed to provide superior return loss without sacrificing insertion loss. This FIC has been recognised as a world class product by the Ministry of Knowledge Economy.

FEATURES

- No epoxy or polishing required
- Superior optical performance
- Quick and easy fibre termination
- High success rate of connections

APPLICATIONS

- Fibre Optic Telecommunications
- Fibre Distribution Frame
- FTTH Outlets
- Optical Cable Interconnection
- Cable Television

COMPATIBLE CABLES

- Round Type, Flat Type, Figure 8 Type
- Aerial Drop Cable, Air Blown Cable
- (250µm / 900µm / 2.0mm / 2.0mm x 2.5mm)

SPECIFICATIONS

Standard	TIA / EIA 604-10 (LC)
Insertion Loss	Typ. 0.15dB/Max. 0.3dB
Return Loss	Typ. 50dB / Max. 55dB (PC) Typ. 55dB / Max. 60dB (APC)
Endurance	≤ 0.3dB, 500 times reconnection
Tension	≤ 0.2dB change, 3.0kg
Temperature Change	≤ 0.3dB change, 21 times / -40°C to +75°C

SC Field Installable Connector (FIC)

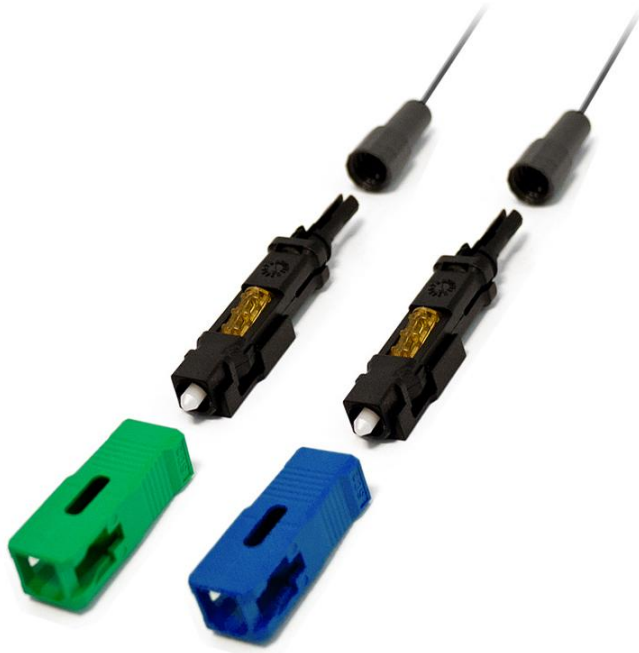

STRUCTURE DIAGRAM & DESCRIPTION

A SC type FIC is the most widely used fibre optic connector in FTTx which does not need epoxy or polishing. It enables fast and on-site installation of 250µm, 900µm, 3.0mm and 2.0mm x 3.0mm cable type connectors, even in areas with no power. Two or three pieces of the pre-assembled and factory terminated connectors can be installed within 2 minutes using simple tools and can be recycled several times.

It facilitates a reliable and durable optical network especially suitable for advance fibre optic systems requiring exceptional stability and low loss. This FIC has been recognised as a world class product by the Ministry of Knowledge Economy.

FEATURES

- No epoxy or polishing required
- Only two (all-in-one type) or three pre-assembled parts
- Quick and easy fibre termination
- High success rate of connections

APPLICATIONS

- Fibre Optic Telecommunication
- Fibre Distribution Frame
- FTTH Outlets
- Optical Cable Interconnection
- Cable Television

COMPATIBLE CABLES

- Round Type, Flat Type, Figure 8 Type
- Aerial Drop Cable, Air Blown Cable
- 250µm / 900µm / 2.0mm / 3.0mm / 2.0mm x 3.0mm

SPECIFICATIONS

Standard	TIA / EIA 604-3 (SC)
Insertion Loss	Typ. 0.15db / Max. 0.3dB
Return Loss	Typ. 50dB / Max. 55dB (PC) Typ. 55dB / Max. 60dB (APC)
Endurance	≤ 0.3dB, 500 times reconnection
Tension	≤ 0.2dB change, 3.0kg
Temperature Change	≤ 0.3dB change, 21 times / -40°C to +75°C

ST Field Installable Connector (FIC)

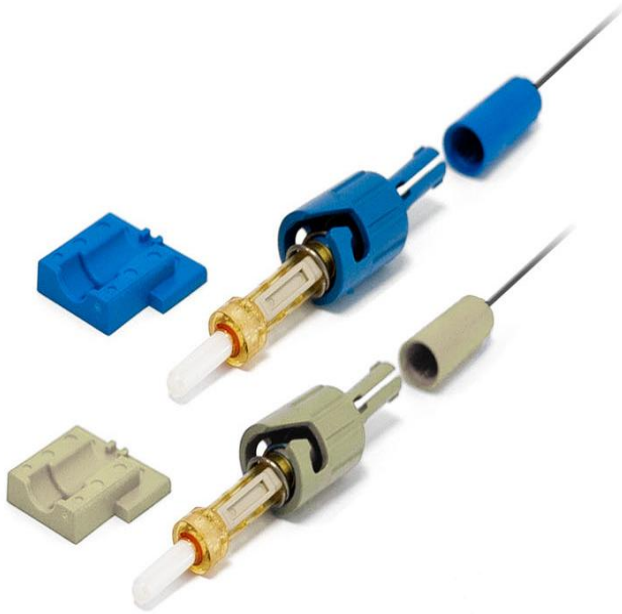

STRUCTURE DIAGRAM & DESCRIPTION

A ST type FIC is the most widely used fibre optic connector in FTTx which does not need epoxy or polishing. It can be installed within 2 minutes using simple tools and can be recycled several times. The ST type is a small design with great details and high technology. All the parts are made from Ultem™ to withstand high temperatures and external shocks. It is available in several configurations to suit different singlemode and multimode applications. The APC connector is designed to provide superior return loss without sacrificing insertion loss.

FEATURES

- No epoxy or polishing required
- Only two (all-in-one type) or three pre-assembled parts
- Quick and easy fibre termination
- High success rate of connections

APPLICATIONS

- Fibre Optic Telecommunication
- Fibre Distribution Frame
- FTTH Outlets
- Optical Cable Interconnection
- Cable Television

SPECIFICATIONS

Standard	TIA / EIA 604-3 (SC)
Insertion Loss	Typ. 0.15db / Max. 0.3dB
Return Loss	Typ. 50dB / Max. 55dB (PC) Typ. 55dB / Max. 60dB (APC)
Endurance	≤ 0.3dB, 500 times reconnection
Tension	≤ 0.2dB change, 3.0kg
Temperature Change	≤ 0.3dB change, 21 times / -40°C to +75°C

COMPATIBLE CABLES

- Round Type, Flat Type, Figure 8 Type
- Aerial Drop Cable, Air Blown Cable
- 250µm / 900µm / 2.0mm / 3.0mm / 2.0mm x 3.0mm



Fixed Attenuators



STRUCTURE DIAGRAM & DESCRIPTION

Our fixed attenuators are designed for reducing optical power levels in a network to match the receiver's requirements. Our range of high performance attenuators are designed to give accurate attenuation over a wide range of wavelengths. Our attenuators are presented with a plug type configuration; allowing for ease of use and functionality. Straight out of the box, these attenuators allow for direct connection to a fibre patchcord, for insertion into the relevant ICL's adapter.

FEATURES

- Fixed attenuation values of 1, 2, 3, 5, 10, 15 and 20 dB (others available)
- Accurate and tested attenuation
- Available with ST, SC, LC, FC and MU packages
- Flat response over all wavelengths
- Plug-in type
- Environmentally stable
- Complies with Telcordia requirement GR-910-CORE

SPECIFICATIONS

Compatible Adapters	Nm	1310 & 1550 (singlemode); 1550 (DSF); 850nm OR 1300nm (multimode)
Attenuation Tolerance	dB	1dB \leq 0.3dB (Typical)
Return Loss	dB	> 40 – 60
PDL	dB	0.1
Operating Temperature	°C	-40°C - +75°C
Storage Temperature	°C	-40°C - +85°C

Attenuated Patchcord (In-Line)

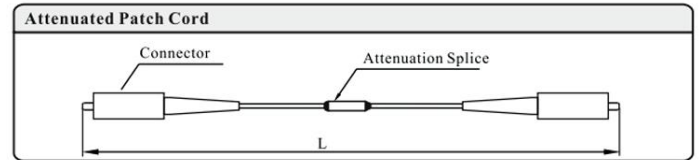

In-line

STRUCTURE DIAGRAM & DESCRIPTION

ICL's high performance attenuated patchcords are used to attenuate optical power in an optical system. The attenuated patchcord can be used to replace the conventional cable assembly and attenuator combination. It is a compact, multi-purpose passive device designed to operate at 1310 and 1550nm wavelengths. ICL provides attenuated patchcords with various connectors, including SC, ST, FC, LC, MU and hybrid types.

FEATURES

- Simultaneously functions as an attenuator and a patchcord
- Various connector types available
- Conforms to EIA/TIA standards
- 100% insertion loss testing
- Wavelength-insensitive
- Mode noise suppression
- Low polarization dependent loss
- High laser power endurance
- Fixed and variable attenuation

APPLICATIONS

- Telecommunication systems
- Cable television networks
- Test equipment
- Data communications networks
- Local Area Networks

SPECIFICATIONS

PARAMETERS		CHARACTERISTICS
Attenuation		1 to 30dB (1dB increment)
Operating Wavelength		1310nm / 1550nm
Tolerance - Attenuation 1 to 10dB, 11 to 30dB		±0.5dB, ±1.0dB
Attenuated Patchcord		1 ~ 2m
In-Line Attenuation		2 ~ 10m
Return Loss		PC type : < -50dB / APC type : < -60dB
Polarization Dependent Loss		< 0.5dB
Operating Temperature		-20°C to +70°C
INTERFEROMETER	PC TYPE	APC TYPE
Radius Of Curvature	7mm ~ 25mm	5mm ~ 12mm
Apex Offset	Max. 50µm	Max. 50µm
Fiber Height	-50nm ~ 50nm	-50nm ~ 50nm
Tilt Error on APC 8'	None	±0.3

* Interferometer measuring equipment : CC6000 / Norland, ACCIS NC-3000 / Norland

* Specification for all connector types (SC, LC, ST, FC MU) is the same

Fibre Optic Multimode Patchcords

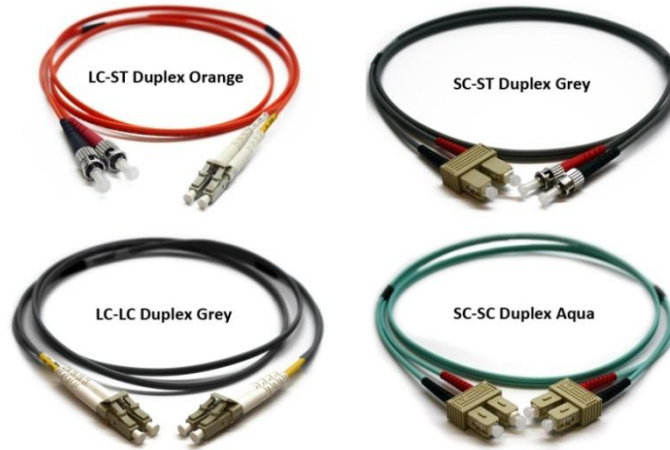

STRUCTURE DIAGRAM & DESCRIPTION

Multimode optical fiber is suitable for communication over short distances, such as in an office building or school. Multimode fibre equipment is cheaper than singlemode; due to its high capacity and reliability, multimode fiber is ideal for backbone applications.

FEATURES

- Connector options: E2000, FC, LC, MTRJ, SC and ST
- Simplex and Duplex configuration
- Choice of cable colour and length
- Robust construction
- LSZH cable jacket
- Each patchcord supplied with test certificate & optical results

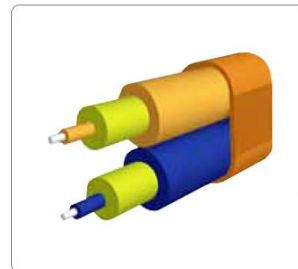

For Your Information:
All duplex patchcords are also available in flat duplex.

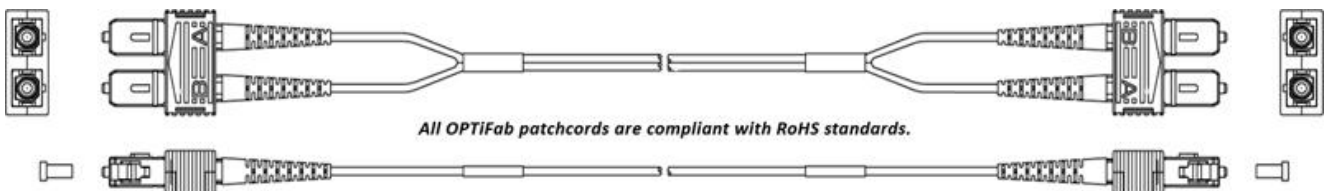

SPECIFICATIONS

Insertion Loss	Typical 0.2 dB (PC / UPC)
Return Loss	N/A
Max.Tensile Load	100N/cm
Apex Offset	≤50 um, ≤100 um
Fire Performance	LSZH for outdoor/indoor
Attenuation	850/1300 = 2.8/0.8
Fibre Spherical Height	-90 nm, +50 nm
Operating Temperature	-20°C to +70°C
Curve Radius	10 to 25mm, 5 to 15mm

Fibre Optic Patch Cord (Singlemode)

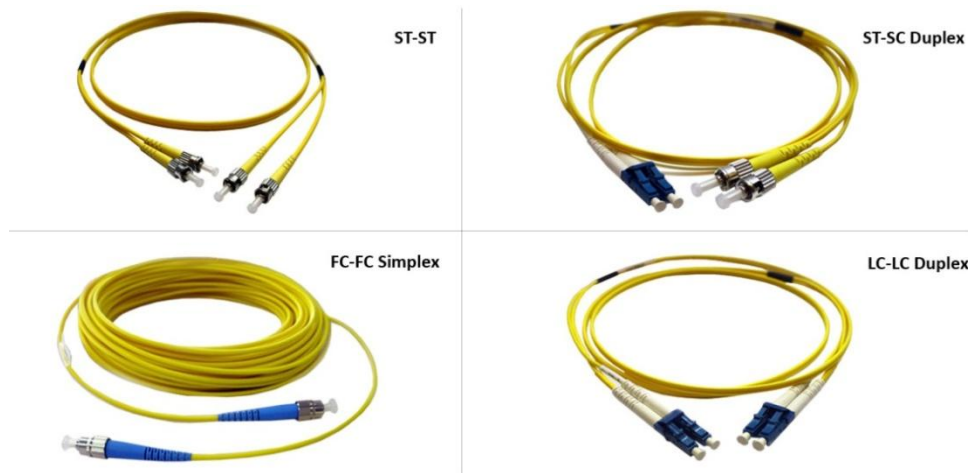

STRUCTURE DIAGRAM & DESCRIPTION

Singlemode optical fibre is characterised by its narrow modal dispersion (8.3 to 10 micron diameter); better retaining fidelity of light pulses and exhibiting higher bandwidth than multimode. As a result, singlemode fibre is ideal for long distance applications.

FEATURES

- Connector options: E2, FC, LC, MTRJ, SC, ST and APC types
- Simplex and Duplex configuration
- Choice of cable colour and length
- Robust construction
- LSZH cable jacket
- Each patch cord supplied with test certificate and optical results

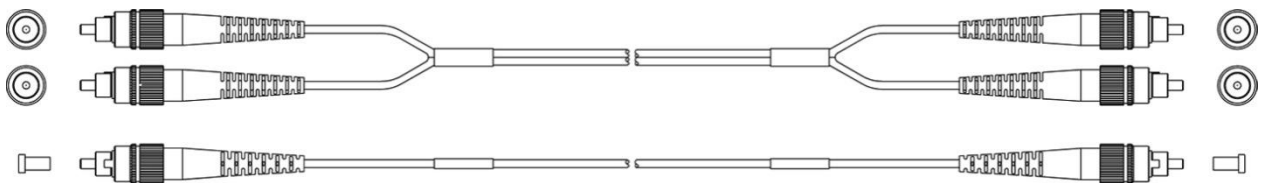

SPECIFICATIONS

Insertion Loss	Typical 0.2 dB (PC / UPC)
Return Loss	Typical 50 dB max 60 dB (APC)
Max.Tensile Load	100N/cm
Apex Offset	≤50 um, ≤100 um
Fire Performance	LSZH for outdoor/indoor
Attenuation	1300/1550 = 0.38/0.24
Fibre Spherical Height	-90 nm, +50 nm
Operating Temperature	-20°C to +70°C
Curve Radius	10 to 25mm, 5 to 15mm

FOR YOUR INFORMATION:

All duplex patch cords are also available in flat duplex

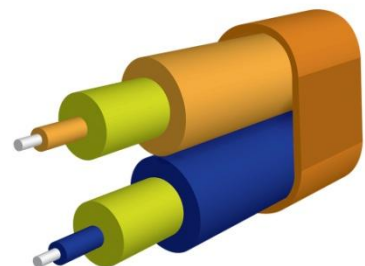

Ordering Information

CABLE LENGTH	
1M	1
2M	2
3M	3
5M	5
7M	7
10M	10
15M	15
20M	20
25M	25
XX	SPECIFY

CONNECTOR END A	
LC	LC
LC/APC	LCA
SC	SC
SC/APC	SCA
ST	ST
FC	FC
MTRJ	MJ
E2000	E2
E2000/APC	E2A

CONNECTOR END B	
LC	LC
LC/APC	LCA
SC	SC
SC/APC	SCA
ST	ST
FC	FC
MTRJ	MJ
E2000	E2
E2000/APC	E2A

MODE	
OM1	62
OM2	50
OM3	OM3
OM4	OM4
OS2 / G657A1	09
G657A2	7A2

DUPLEX/SIMPLEX	
DUPLEX	D
SIMPLEX	S

COLOR	
ORANGE	OR
AQUA	AQ
VIOLET	EV
YELLOW	YE
YY	SPECIFY

SAMPLE PART NUMBER					
3	LC	LC	09	D	YE
3LCLC09DYE3M LC-LC Singlemode Duplex Yellow					



Flat Duplex Patchcord



FEATURES

- Connector options: E2000, FC, LC, MTRJ, SC, ST with UPC and APC polishing available
- Simplex and Duplex configuration
- Choice of cable colour and length
- Robust construction - suitable for outdoor applications
- LSZH cable jacket
- Aramid strength member in each patch cord
- Each patch cord supplied with test certificate and optical results
- Comply with IEC 61300-3-6 and IEC 61300-3-34:2009
- Short & Mini boot 18 mm or less

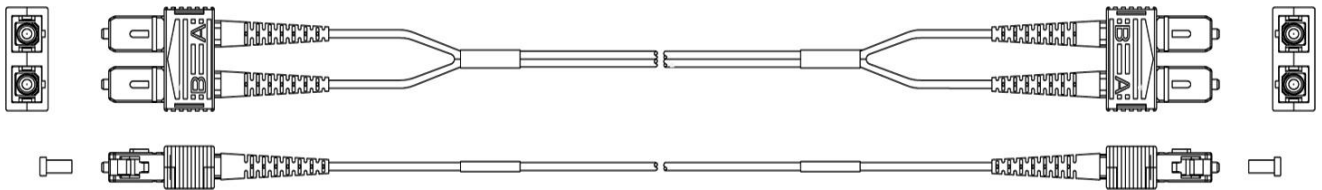

SPECIFICATIONS (Singlemode)

Insertion Loss	Typical ≤ 0.2 dB (PC / UPC)
Return Loss	Typical ≤ -56 dB (UPC) max ≤ -60 dB (APC)
Max. Tensile Load	100N/cm
Apex Offset	≤ 50 μm , ≤ 100 μm
Fire Performance	LSZH for outdoor/indoor
Attenuation	1300/1550 = 0.38/0.24
Fibre Spherical Height	-90 nm, +50 nm
Operating Temperature	-40°C to +80°C
Curve Radius	10 to 25mm, 5 to 15mm

SPECIFICATIONS (Multimode)

Insertion Loss	Typical 0.2 dB (PC / UPC)
Return Loss	N/A
Max. Tensile Load	100N/cm
Apex Offset	≤ 50 μm , ≤ 100 μm
Fire Performance	LSZH for outdoor/indoor
Attenuation	850/1300 = 2.8/0.8
Fibre Spherical Height	-90 nm, +50 nm
Operating Temperature	-20°C to +70°C
Curve Radius	10 to 25mm, 5 to 15mm

CABLE CHARACTERISTICS

- Tight-buffered optical fibre
- Aramid-yarn strength member
- LSZH Durable outer jacket

CABLE APPLICATIONS

- Indoor/Office/LAN
- Patchcords & Pigtails
- Direct Connection to Terminal Equipment

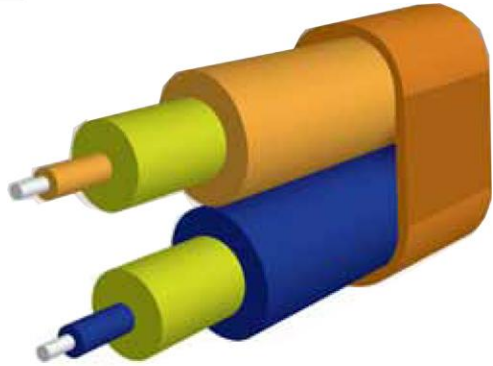

TIGHT BUFFERED SIMPLEX CABLE

Fibre Core	2			
Weight	kg/km	13.1	14.8	25.6
Cable Dimensions	mm	2.4x4.8	3.0x5.0	4.0x7.0
Long-term Tensile Load	N	100	100	160
Short-term Tensile Load	N	200	200	300
Minimum Bend Radius	60mm dynamic/30mm static			
Crush Resistance (LT/ST)	N	300/1000		
Temperature Range	°C	-20 ~ +60		

CABLE FEATURES

- Choice of fibre type
- 100% Dielectric
- High strength aramid-yarn strength member
- Easy to strip with appropriate tool
- Duplex easy and safe to separate
- Choice of outer jacket material and colour
- OS2, OM1, OM2, OM3 and OM4

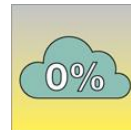

low-smoke
zero halogen



flame retardant



moisture
protected



highly flexible

STANDARDS

- Environmental and mechanical tests according to: EN 187000 and CEI 60794.
- Fire test according to: UNE-EN 50266 (IEC 60332-3) / UNE-EN 50267 (IEC 60754-1) / UNE-EN 50268 (IEC 61034-1/2).
- 1LSZH = Low-smoke Zero-halogen flame retardant thermoplastic compound

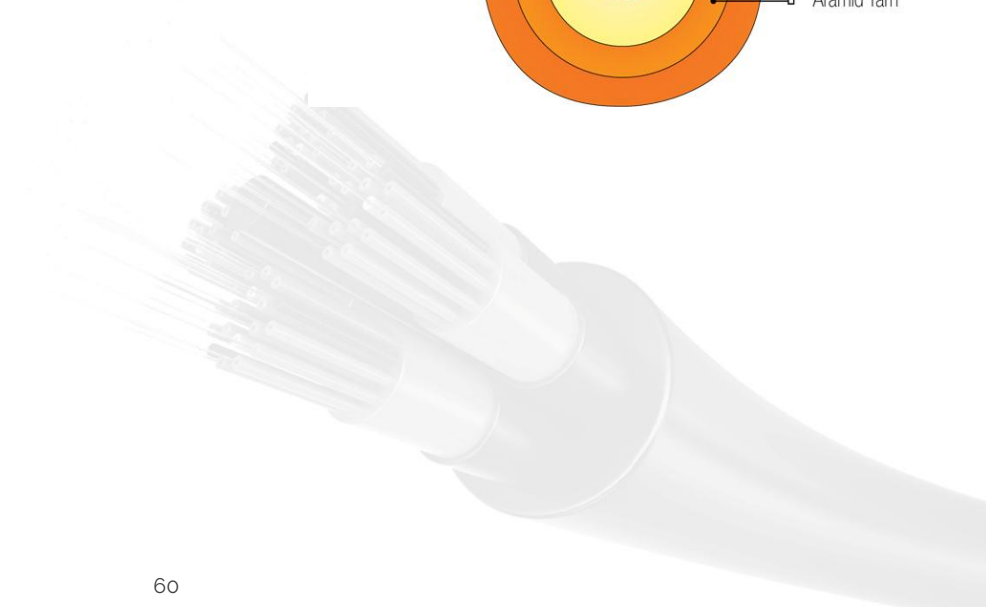
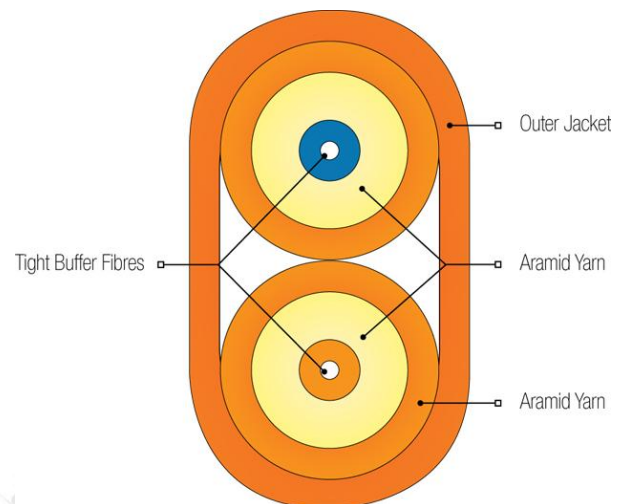

LED Patch Cords



STRUCTURE DIAGRAM & DESCRIPTION

Our series of patch cords offer a quick and accurate method of identifying the termination point of optical patch cords. Each end of ICL patch cords offer a flashing light allowing technicians to visually trace individual patch cords from one end to another without pulling or affecting the patch cord. ICL is supplied with special power sources easily attached to the patch cords. The LED light will blink every 2 seconds, stopping after 30 seconds.

FEATURES

- Easy traceability
- Patented technology
- No effect on patch cord functionality
- Low insertion loss
- High return loss
- High repeatability
- Temperature stabilization

APPLICATION

- WANs, LANs, CATV
- Telecommunications
- Optical Networks
- Testing / Measuring
- ISP center room
- Data Center

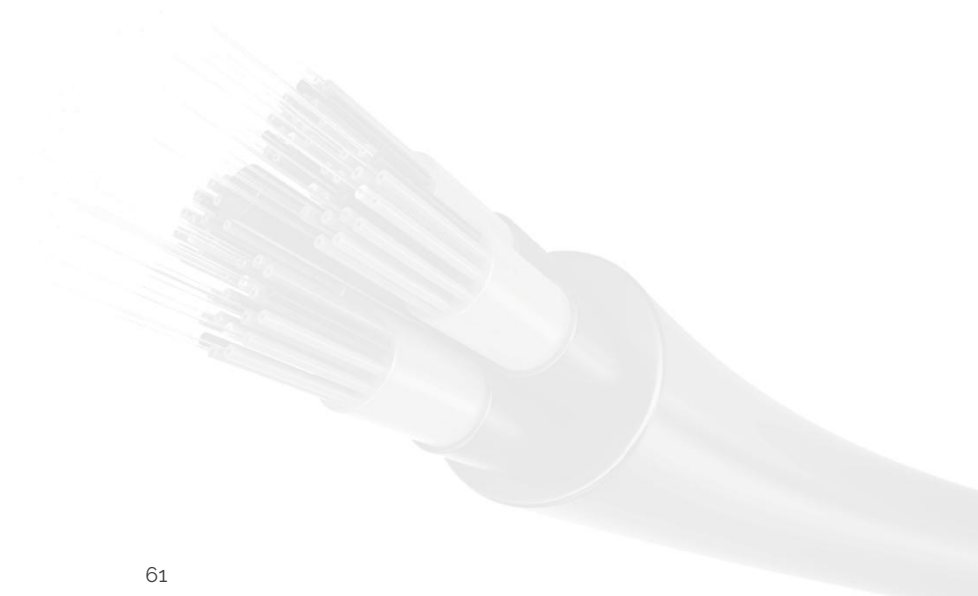

Mode Conditioning Patchcords

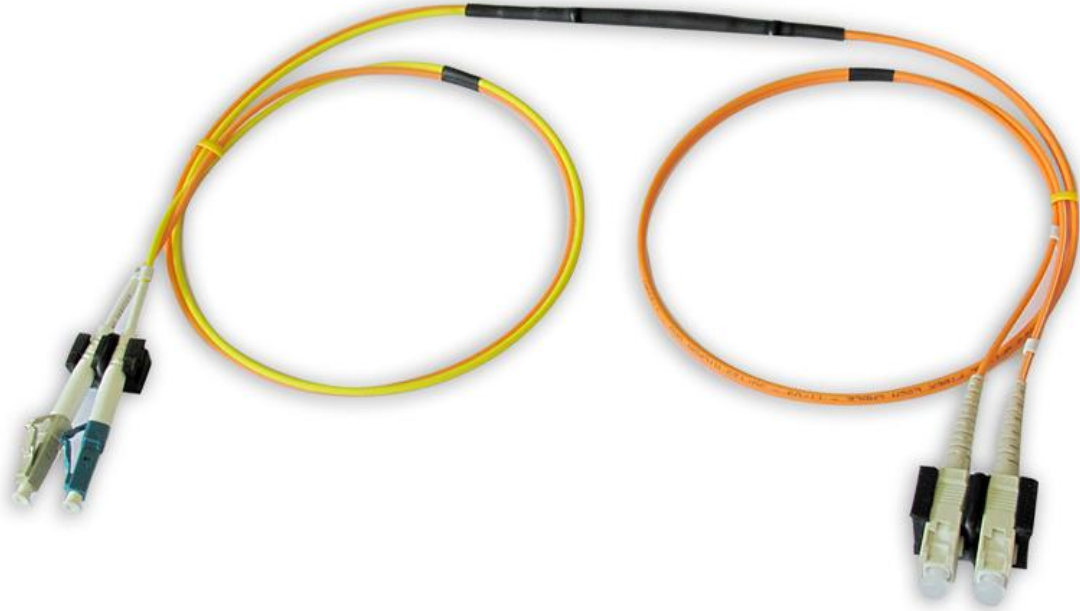

STRUCTURE DIAGRAM & DESCRIPTION

Mode conditioning patchcords are designed for longwave Gigabit Ethernet (1310nm/1000 base-LX) network applications, where both singlemode and multimode interconnects are required. The connection between the singlemode and multimode fibre is slightly offset, resulting in the mode conditioning patchcord removing transmission-distance limiting Differential Mode Delay (DMD), which is present in multimode fibre.

FEATURES

- Connector options: E2000, FC, LC, MTRJ, SC and ST
- Stable and permanent core offset
- Low-loss connections
- Solution to DMD effects
- Installed in the same method as a traditional patchcord



SPECIFICATIONS

	SM 9/125	MM 50/125	MM 62.5/125
Fiber type	SM 9/125	MM 50/125	MM 62.5/125
Fibre Wavelength	1310/1550nm	850/1310nm	850/1310nm
Insertion Loss (typical)	0.3dB	0.2dB	0.2dB
Insertion Loss (max)	0.8dB	0.7dB	0.7dB
Temperature Range	-20 - +70°C	-20 - +70°C	-20 - +70°C
Mating Durability (500 cycles)	<0.2dB	<0.2dB	<0.2dB
Attenuation Max.	3.3 dB/km	1 dB/km	0.5 dB/km
Numerical Aperture (NA)	0.13	0.2	0.275

SC APC Patch Cord (Singlemode) OS1/2

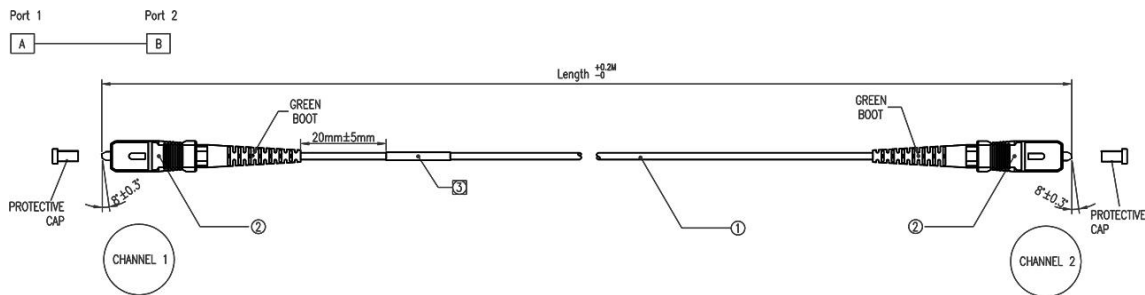
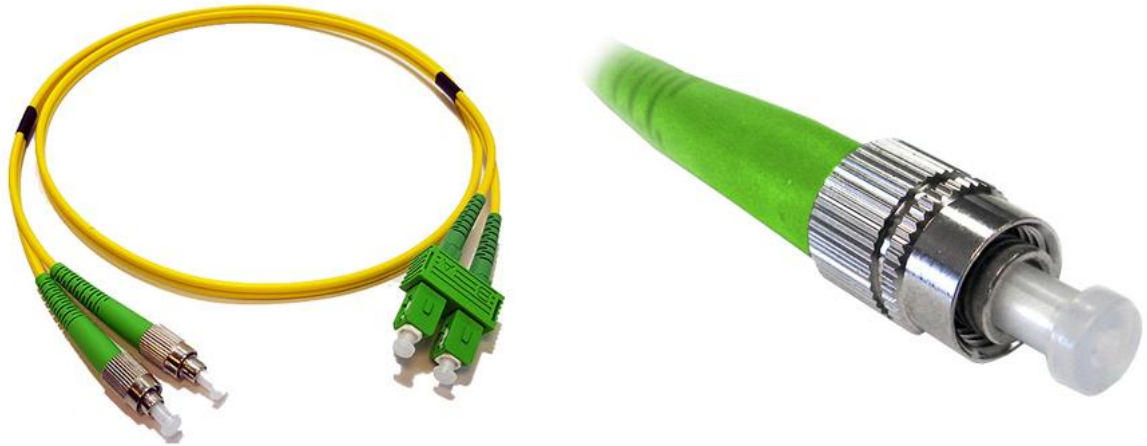

STRUCTURE DIAGRAM & DESCRIPTION

Singlemode optical fibre is characterised by its narrow modal dispersion (8.3 to 10 micron diameter), better retaining fidelity of light pulses and exhibiting higher bandwidth than multimode. As a result, singlemode fibre is ideal for long distance applications. With many years of acquired knowledge and experience, ICL specialises in high quality and reliable patch cords in a variety of lengths, colours and connector configurations. We continually monitor our processes to ensure consistent high quality terminations.

FEATURES

- SC APC Connector
- Simplex configuration
- Choice of cable colour and length
- Robust construction
- LSZH cable jacket
- Each patch cord supplied with test certificate and optical results

SPECIFICATIONS

SC connector dimensions	7.3mm H x 8.9mmW x 55mm D
Maximum connector loss	0.3 dB
Typical connector loss	0.2 dB
Typical return loss	-65 dB
Angle tolerance	8° \pm 1 0.3°
Buffer material	PVC
Buffer OD	900 μ m
Jacket material	LSZH
Jacket OD	2 mm/2.8 mm/3 mm
Installation tensile load	100 N
Long-Term tensile load	50 N
Maximum tensile load	100 N/cm
Installation (loaded)	5.0cm (Min. bend radius)
Long-term (unloaded)	3.0cm (Min. bend radius)
Crush resistance	750 N/cm
Impact resistance	1,000 cycles
Flex resistance	5,000 cycles
Attenuation at 1550 nm	0.25 dB/km
Attenuation at 1310 nm	0.35 dB/km
Operating temperature	-20°C to +70°C

Secure Locking Fibre Optic Patch Cords

Compatible with any STANDARD SC ADAPTOR OR SC PORT



Secure SC Connector designed to prevent unauthorized access or changes

STRUCTURE DIAGRAM & DESCRIPTION

ICL's secure SC connector system is designed to prevent unauthorized or accidental changes to cabling networks in highly sensitive applications including datacentres, military and secure IT networks. The secure SC system is compatible with any new or existing SC ports in devices such as patch panels and active equipment. The SC connectors can only be unplugged using a matching, colour coded extraction tool. These keyed tools allow the connector to be automatically removed from the port. Access to empty or unused ports can be prevented using similarly keyed, colour coded SC port blockers.

SECURE SC



Locking Connector

SECURE SC

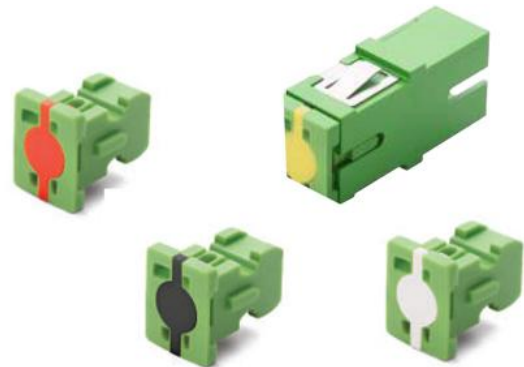

Port Blocker

OPTICAL SPECIFICATIONS AND CONNECTOR OPTIONS

Insertion Loss	0.1dB typical for SM UPC, SM APC, MM PC
Return Loss	55dB for SM UPC, 65dB for SM APC
Lock Key Options	4 key configuration in 4 colours: red, yellow, black and white
Boot / Cable option	3mm & 2mm boots, flex angle boot also available
Operating Temperature	-40°C to +75°C
Mechanical requirement	To meet and exceed GR-326 core issue 4

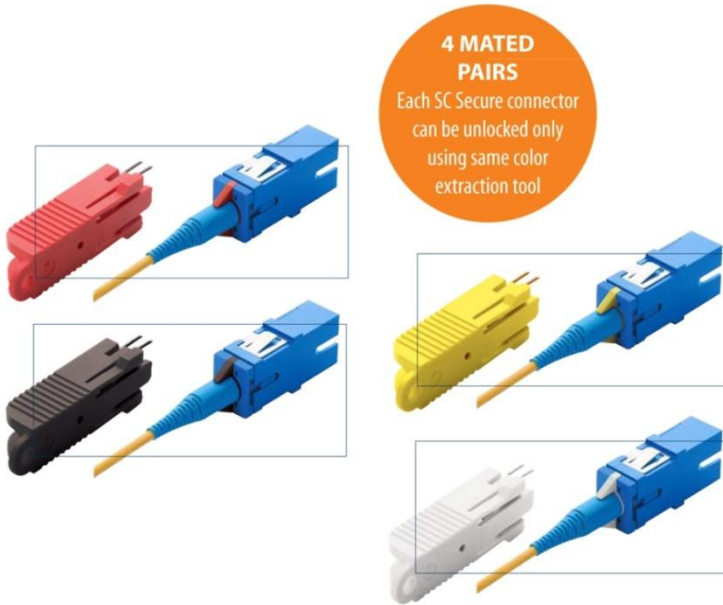

SECURE SC & EXTRACTION TOOL

Secure SC cable assemblies and matching extraction tools are available in four keyways, signified by four different colours (as per image on the left). Singlemode and multimode cable assemblies can be customized to suit individual customers' requirements.

Complementing the secure SC connectors, ICL also supplies secure SC locking port blocks. These effectively act as locking dust caps, enabling empty SC ports to be locked, preventing unauthorized use.

Port blockers are disconnected in the same way as the secure SC connectors, by using the matching colour-coded extraction tool.

FEATURES

- True locked keyed connector security
- Multiple key configurations of access control and tamperproofing
- Compatible with all industry standard passive and active SC ports Industry standard colour coding of housings for easy identification and administration of SM and MM ports
- Port blockers available for 'protecting' unused ports

APPLICATIONS

- FTTX bi-directional networks
- Telecom rooms & ODF's
- Secure military IT networks
- Commercial enterprise networks
- Datacenters
- Customer premise connections
- Test labs

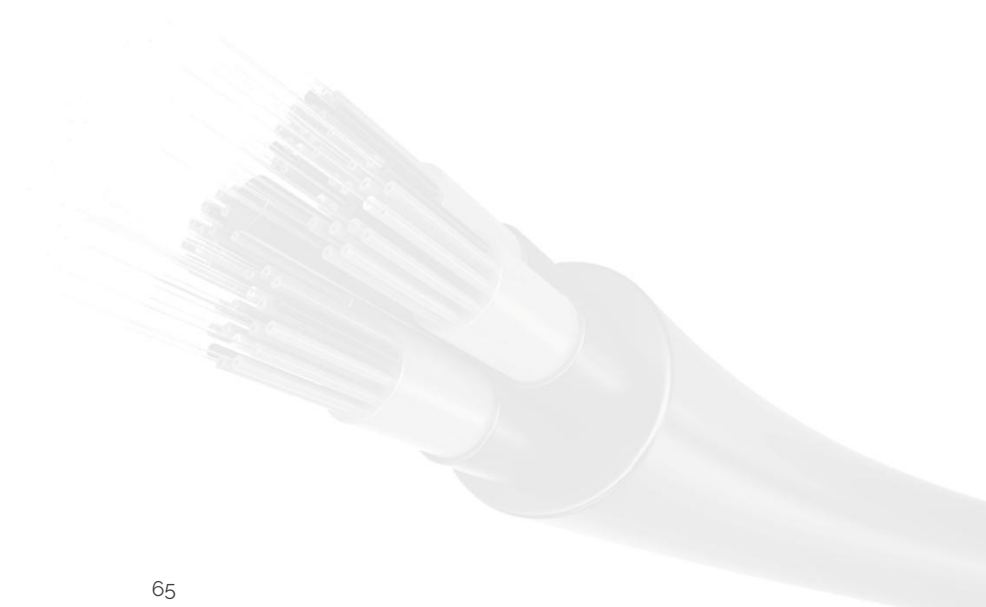

Steel Tape Armoured Patchcord

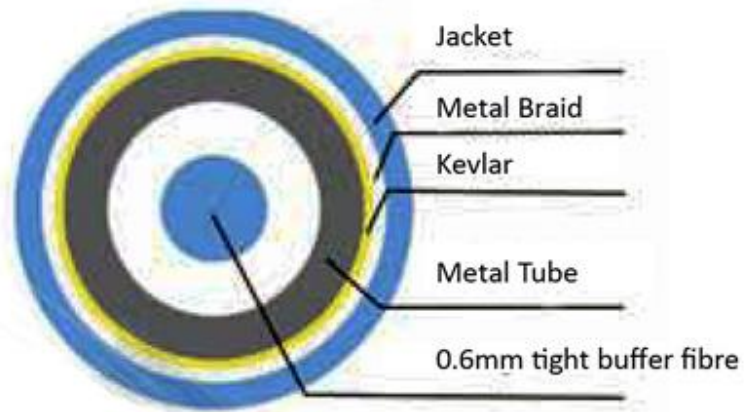

STRUCTURE DIAGRAM & DESCRIPTION

Armoured patchcords are used in areas or applications where additional safeguards are required to ensure added cable protection. The stainless steel armoured construction is designed to provide strength, but remains flexible enough for interconnection and routing.

FEATURES

- Good mechanical and environmental properties
- Flame-retardant performance
- Strong and durable agile
- Satisfies various customer and market requests

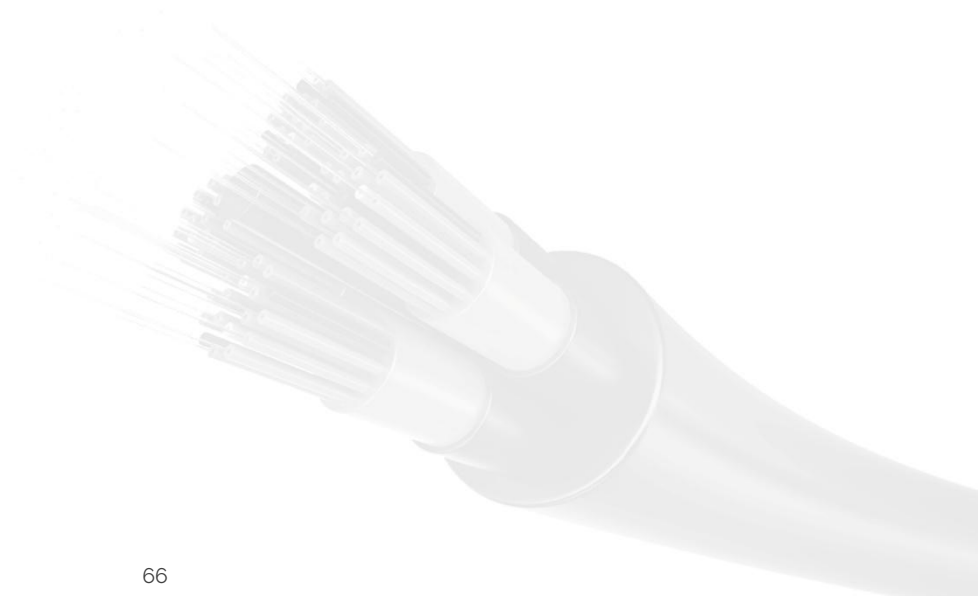

Single & Multi Fibre Launch Boxes



FEATURES

- Watertight, crushproof and dustproof
- Easy to open with secure double latches
- Strong and lightweight open shell core with solid wall design
- O-ring seal
- Automatic pressure equalization valve
- Ideal for onsite and harsh environment use

SPECIFICATIONS



Single Fibre Mini Launch Box

- Dimensions – 190mm x 128mm x 54mm
- Capacity-up to 500mtr of fibre
- 1mtr tail length
- All Simplex connector types available



Single Fibre Yellow Launch Box

- Dimensions – 206mm x 167mm x 90mm
- Capacity - up to 1km of fibre
- Custom tail lengths
- All Simplex connector types available



Multi Fibre Medium Launch Box

- Dimensions – 340mm x 295mm x152mm
- Capacity - up to 3x 2km of fibre
- Custom tail lengths



Multimode Pigtails



STRUCTURE DIAGRAM & DESCRIPTION

Multimode optical fibre is suitable for communication over short distances, such as in an office building or a school. Multimode fibre equipment is cheaper than singlemode, and due to its high capacity and reliability, multimode fibre is ideal for backbone applications.

FEATURES

- Connector options: E2000, FC, LC, MTRJ, SC, ST and APC types
- Choice of fibre colour and length
- Each pigtail supplied with test certificate and optical results
- Operating temperatures from -20°C to +70°C

SPECIFICATIONS

Insertion	Typical 0.2 dB (PC / UPC) 0.3dB Max
Return Loss	N/A
Max.Tensile Load	100N/cm
Apex Offset	≤50 um, ≤100 um
Fire Performance	LSZH for outdoor/indoor
Attenuation	850/1300 = 2.8/0.8
Fibre Spherical Height	-90 nm, +50 nm
Operating Temp.	-40°C to +80°C
Curve Radius	10 to 25mm, 5 to 15mm

Singlemode Pigtails



STRUCTURE DIAGRAM & DESCRIPTION

SINGLEMODE

Singlemode optical fibre is characterised by its narrow modal dispersion (8.3 to 10 micron diameter); better retaining fidelity of light pulses and exhibiting higher bandwidth than multimode. As a result, singlemode fibre is ideal for long distance applications.

FEATURES

- Connector options: E2000, FC, LC, MTRJ, SC, ST and APC types
- Choice of fibre colour and length
- Each pigtail supplied with test certificate and optical results

SPECIFICATIONS

Insertion Loss	Typical 0.2 dB (PC / UPC) Max 0.3dB
Return Loss	Typical 50 dB max 60 dB (APC)
Max.Tensile Load	100N/cm
Apex Offset	≤50 um, ≤100 um
Fire Performance	LSZH for outdoor/indoor
Attenuation	1300/1550 = 0.38/0.24
Fibre Spherical Height	-90 nm, +50 nm
Operating Temp.	-40°C to +80°C
Curve Radius	10 to 25mm, 5 to 15mm

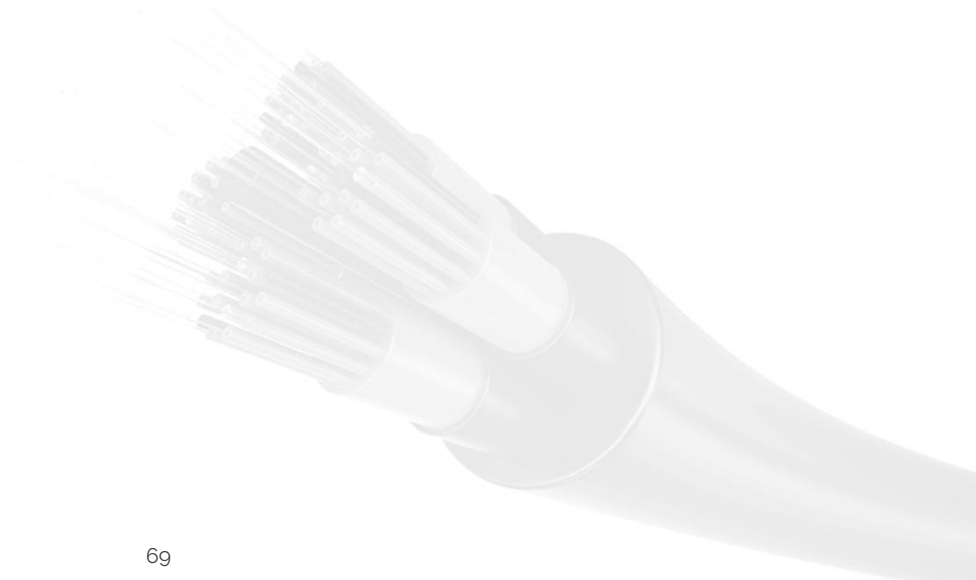

SC/APC Pre-Connectorised 2F MINI 2.5 Pigtail Reel

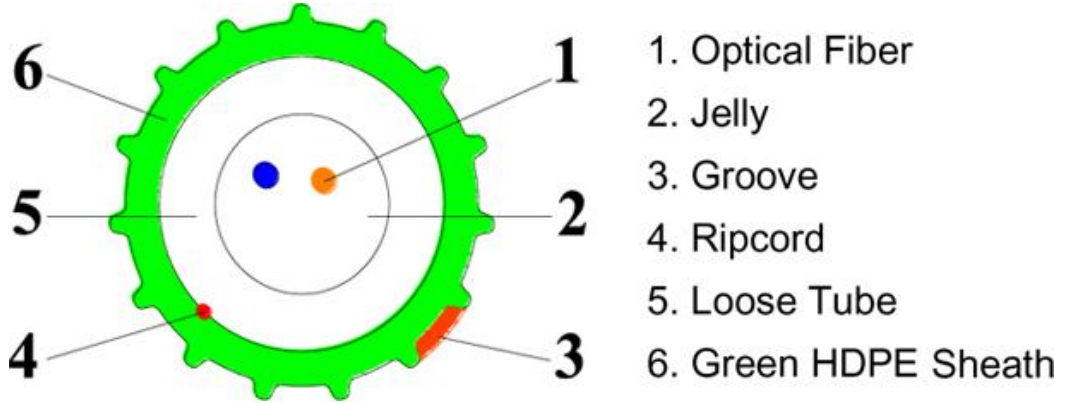

STRUCTURE DIAGRAM & DESCRIPTION

The SC/APC pre-connectorised 2 fibres MINI 2.5 pigtail reel is routed from the 5/3.5mm micro duct into the OFDF shelf after installing blown fibre. The installation length is up to 150m, and the packaging drum is suitable for mounting on the Ericsson Blowing Gun.

FEATURES

- 2 fibres MINI 2.5
- Suitable for singlemode G652D optical fibre
- Complete accessories, less manpower, lower installation time.

TECHNICAL PARAMETERS

Fibre Count	2 Fibres (G.652.D)
Outer Diameter (mm)	2.5±0.1
Weight (g/m)	6.0
Min Bend radius (mm)	50
Attenuation 1310/1550nm	≤0.36/0.22 dB/km
Temperature range	Storage : -30°C ~ +70°C Operation : -40°C ~ +75°C Installation : -5°C ~ +50°C
Insertion Loss	≤0.3 dB
Return Loss	≥60.0 dB

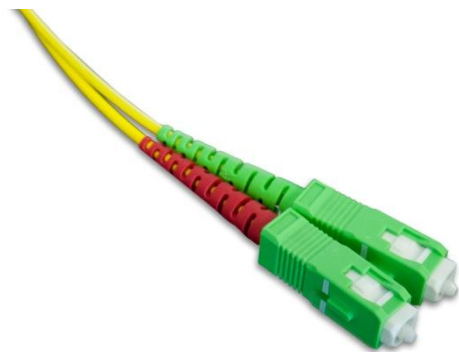

SC/APC CONNECTOR (Φ0.9mm,1.5m)

PACKAGING

Length	Drum size (mm)
2 SC/APC + 50m MINI 2.5	φ265×100
2 SC/APC + 100m MINI 2.5	φ265×100
2 SC/APC + 150m MINI 2.5	φ265×100
Box Size (mm) Length×Wid×High	590 × 560 × 320
Number	12 drums / box
2 SC/APC + 150m MINI 2.5	50m : 10kg, 100m : 14kg, 150m : 18kg

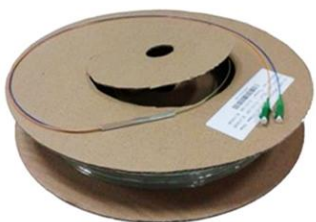

Pre-Terminated Fibre Solutions



STRUCTURE DIAGRAM & DESCRIPTION

Our pre-terminated fibre solutions allow our customers to order complete assemblies ready for direct installation, cutting on-site time and labour costs. Supplied on a drum with protective packaging to ensure that the fibre and all pre-term components arrive in perfect condition. Internal/external LSZH cables jackets meet all fire safety standards.

FEATURES

- Internal and external use
- Option of 2mm/3mm breakout for ruggedised use
- Staggered tails or fan-out
- Labelled for identification
- Choice of cable colour
- Singlemode and multimode fibre options
- Choice of connectors available in connector range
- Clear protective sock
- Available in custom lengths
- Supplied with test certificate and optical results

CONNECTOR OPTIONS

- FC / LC / MTRJ / MU / SC / ST / E2 / E2A

FIBRE TYPES AVAILABLE

- Tight buffered
- Loose tube
- Corrugated steel tape armoured
- Steel wire armoured

Breakout Cable 2 - 16 fibre (with 2mm sub cables)

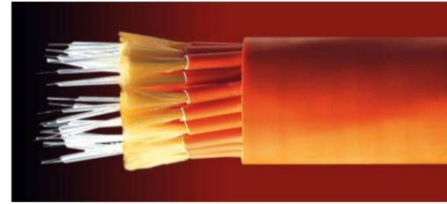
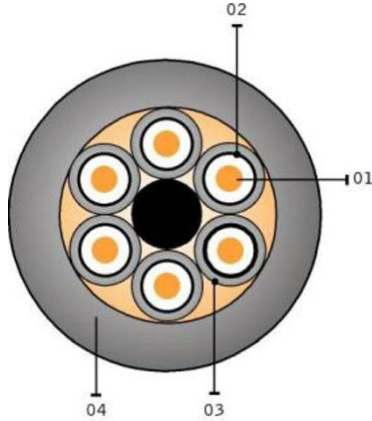

STANDARDS

Mechanical and environmental tests according to IEC 60794-1-21 and IEC 60794-1-22 LSZH, halogen free, low smoke and flame retardant thermoplastic compound



STRUCTURE DIAGRAM & DESCRIPTION

Compact / Resilient / Tough / Excellent mechanical resistance / Easy to strip (gel free) / Totally dielectric / Reduced diameter / Direct connectorization

CABLE DESCRIPTION

1. Tight Buffer Fibre (0.9 mm)
2. Strength Members
3. Individual Jacket (\varnothing 2.1 mm)
4. Outer Jacket

OPTIONS

- Jacket: PVC / PE / PU / PA
- Special colour code

FIRE RESISTANCE

- Flame retardant (IEC 60332-3)
- Halogen free (IEC 60754-1/-2)
- Low smoke emission (IEC 61034-2)

CPR CLASSIFICATION (EUROCLASS)

- Reaction to Fire: Dca, s2, d2, a1
- Declaration Code: DOP02100

APPLICATIONS

- Indoor
- Direct connection to terminal equipments
- Based on DIN VDE 0888 part 6

SPECIFICATIONS

PARAMETERS	CHARACTERISTICS					
	2	4	6	8	12	16
Fiber	2	4	6	8	12	16
Strength member of sub cables	Aramid Yarns					
Central Filler	Yes					
Sub-cables Jacket	LSZH ¹					
Identification	Numbers					
Outer jacket	LSZH ¹					
Colour	Orange (MM62) / Blue (MM50) / Yellow (SM)					
Weight (Kg/Km)	45	45	63	89	153	136
Outer \varnothing (mm)	7.1 \pm 0.3	7.1 \pm 0.3	8.3 \pm 0.3	9.8 \pm 0.3	12.6 \pm 0.5	12.6 \pm 0.5
Tensile Load Perm / Inst (N)	700 / 1250	900 / 1600	1200 / 2150	1500 / 2700	2000 / 3600	2500 / 4000
Max. Crush (N/dm)	1500 - (IEC 60794-1-21 E3)					
Temperature Range	-20 °C to +70 °C - (IEC 60794-1-22 F1)					
Min. Bending Radius (mm)	20 x Outer \varnothing - (IEC 60794-1-21 E11)					

Breakout Cable 24 - 48 fibre (with 2mm sub cables)

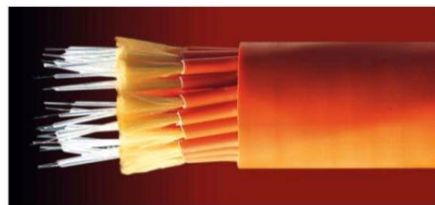
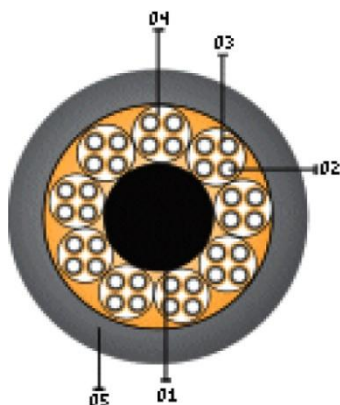

STANDARDS

Mechanical and environmental tests according to IEC 60794-1-21 & IEC 60794-1-22 LSZH, halogen free, low smoke and flame retardant thermoplastic compound



STRUCTURE DIAGRAM & DESCRIPTION

Compact / Resilient / Tough / Excellent mechanical resistance / Easy to strip (gel free) / Totally dielectric / High fiber count / Direct connectorization

CABLE DESCRIPTION

1. Central Element (GRP)
2. Tight Buffer Fibre (0.9 mm)
3. Strength Members
4. Individual Jacket (Ø 2.1 mm)
5. Outer Jacket

OPTIONS

- Jacket: PVC / PE / PU / PA
- Special colour code
- Buffer Easy-Strip

FIRE RESISTANCE

- Flame retardant (IEC 60332-1 / IEC 60332-3)
- Halogen free (IEC 60754-1/-2)
- Low smoke emission (IEC 61034-2)

CPR CLASSIFICATION (EUROCLASS)

- Reaction to Fire: Dca, s2, d2, a1
- Declaration Code: DOP02100

APPLICATIONS

- Indoor
- Direct connection to terminal equipments
- Based on DIN VDE 0888 part 6

SPECIFICATIONS

PARAMETERS	CHARACTERISTICS			
	24	32	36	48
Fiber	24	32	36	48
Strength member of sub cables	Aramid Yarns			
Min. Bending Radius (mm)	20 x Outer Ø (IEC 60794-1-21 E11)			
Sub-cables Jacket	Thermoplastic [Ø Sub-cables - 2.1 mm]			
Identification	Numbers			
Outer jacket	LSZH ¹			
Colour	Orange (MM62) / Blue (MM50) / Yellow (SM)			
Weight (Kg/Km)	251	351	420	389
Outer Ø (mm)	16.5 ±0.5	19.5 ±0.5	21.1 ±0.5	22.9 ±0.5
Tensile Load Perm / Inst (N)	900 / 1650	1200 / 2150	1500/2700	2000/3600
Max. Crush (N/dm)	(IEC 60794-1-21 E3)			
Max. Tensile Load (N)	3000 (Operating) / 4000 (Installation) - (IEC 60794-1-21 E1)			
Temperature Range	-20 °C to +70 °C - (IEC 60794-1-22 F1)			
Maximum Length (m) on drum	850			

Military Breakout Cable (Up to 12 Fibres)

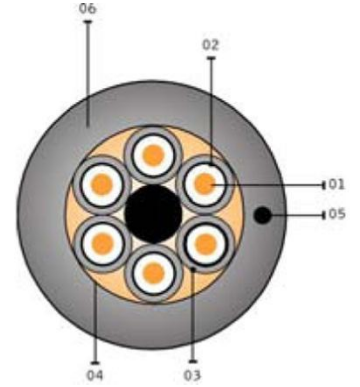
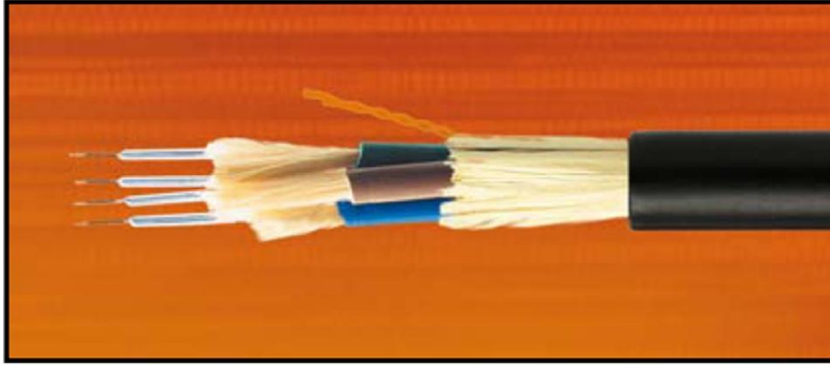

STRUCTURE DIAGRAM & DESCRIPTION

Compact / Resilient / Tough / Excellent mechanical resistance / Easy to strip (gel free) / Totally dielectric / Based on military norm / Direct connectorization

CABLE DESCRIPTION	NORMS / APPROVALS	OPTIONS
<ol style="list-style-type: none"> Tight Buffer Fibre (0.9 mm) Aramid Individual Jacket (Ø 2.5 mm) Ripcord Outer Jacket 	<ul style="list-style-type: none"> Based on military norm MIL-C-85045 	<ul style="list-style-type: none"> Easy-Strip Buffer PU-LSZH Jacket

SPECIFICATIONS

Fibres	2	4	6	8	12	-
Strength member of sub cables	Aramid Yarns					
Subcables Ø (mm)	2.5					
Subcables Jacket	Thermoplastic LSZH ¹					
Identification	Colours ²					
Outer Jacket	Polyurethane					
Colour	Black					
Max. Length	3200 m					
Weight (Kg/Km)	63	63	87	124	202	-
Outer Ø (mm)	9.0 ^{±0.3}	9.0 ^{±0.3}	10.5 ^{±0.3}	12.2 ^{±0.5}	15.5 ^{±0.5}	-
Tensile Load Perm / Inst (N)	900 / 1600	1200 / 2150	1500 / 2700	1900 / 3400	2500 / 3500	-
Crush (N)	2000					
Temperature Range	-40 °C to +70 °C					
Min. Bending Radius (mm)	20 x Outer Ø					

STANDARDS

- LSZH – LSZH – Halogen free, low smoke and flame retardant thermoplastic compound
- Colour Fibres = Blue – Orange – Green – Brown – Grey – White – Red – Black – Yellow – Violet – Pink – Turquoise



Military Distribution Cable (Up to 12 Fibres)

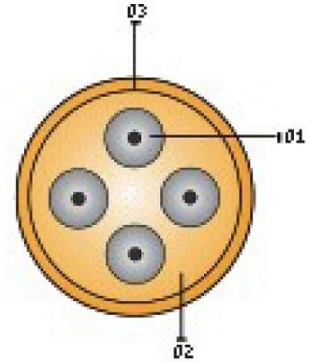

STRUCTURE DIAGRAM & DESCRIPTION

Compact / Resilient / Tough / Excellent mechanical resistance / Easy to strip (gel free) / Totally dielectric / Based on military norm / Direct connectorization

CABLE DESCRIPTION	NORMS / APPROVALS	OPTIONS
<ol style="list-style-type: none"> 1. Tight Buffer Fibre (0.9 mm) 2. Aramid 3. Outer Jacket 	<ul style="list-style-type: none"> • Based on military norm MIL-C-85045 • EN187000, IEC60794-1-2 	<ul style="list-style-type: none"> • Easy-Strip Buffer • PUR-LSZH Jacket • SM(G657A)/OM1/OM2/OM3/OM4

SPECIFICATIONS

Fibres	2	4	6	8	10	12
Strength member of sub cables	Aramid Yarns					
Outer Jacket	PUR-FR					
Colour	Black					
Crush (N)	4400					
Weight (Kg/Km)	21	24	29	36	45	49
Outer Ø (mm)	5.0 ±0.3	5.8 ±0.3	6.0 ±0.3	6.5 ±0.3	7.4 ±0.3	8.2 ±0.3
Tensile Load Perm / Inst (N)	600 / 1100			2500 / 3500		
Maximum Length	4200 m					
Temperature Range	-55 °C to +85 °C					
Min. Bending Radius (mm)	20 x Outer Ø					

STANDARDS

Colour Fibres = Blue – Orange – Green – Brown – Grey – White – Red – Black – Yellow – Violet – Pink – Turquoise



External Loose Tube Cable 16-144 core

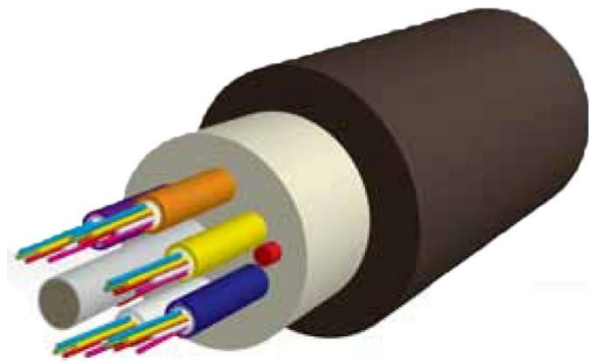
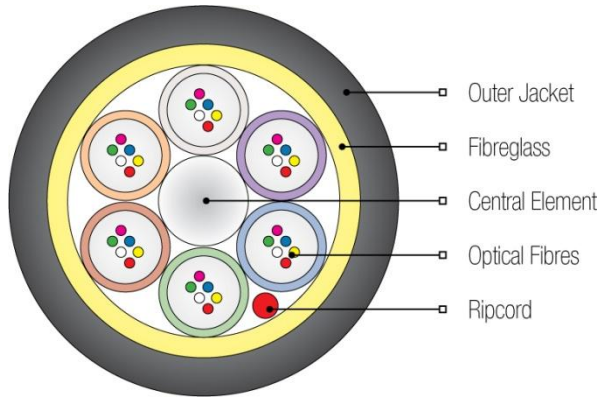

FEATURES

- Choice of fibre type
- Choice of colour coded fibres
- 100% Dielectric
- Excellent friction resistance
- Water blocking fibreglass reinforcements
- Choice of outer jacket material and colour
- OS2, OM1, OM2, OM3 and OM4

CABLE CHARACTERISTICS

- 250µm colour-coded optical fibre
- Gel filled loose-tubes for fibre lubrication and water repping properties
- Central Element (GRP)
- Ripcord
- Durable outer jacket

APPLICATIONS

- External duct applications
- Suitable for "blown air" systems

MULTI LOOSE TUBE CABLE (16-144)

Fibre Count	16	24	32	36	48	64	72	96	128	144	
Fibres/Tube	4	6	8	6	12	8	12	12	8	12	
Total Tubes	4	4	4	6	4	8	6	8	18	14	
Active Tubes	4	4	4	6	4	8	6	8	16	12	
Weight	kg/km	63	64	74	82	84	134	119	157	194	181
Outer Diameter	mm	9.3	10.2	10.5	11	13.2	12.6	14.3	16.7	17	
Tensile Load (LT)	N	1000				1500					
Tensile Load (ST)	N	1800				2700					
Min. Bend Radius	20x Outer Diameters										
Maximum Length	m	4200	3100	4200	2100	3100	2100	3100	2100	2100	
Temperature	°C	-40~+70									
Colour	Black										
Crush Resistance	N	2000									

STANDARDS

Environmental and mechanical tests according to: EN 187000 and CEI 60794

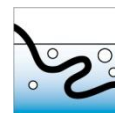

watertight



rodent protection



moisture protected



ultraviolet resistant

Fibre Colour Options:

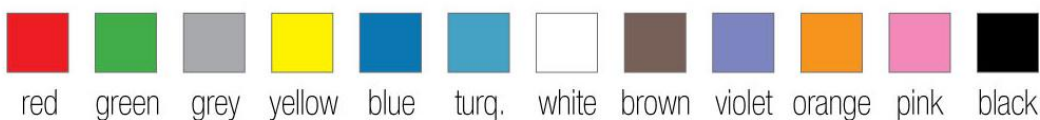

Non-Armored Multi-Tube Cable

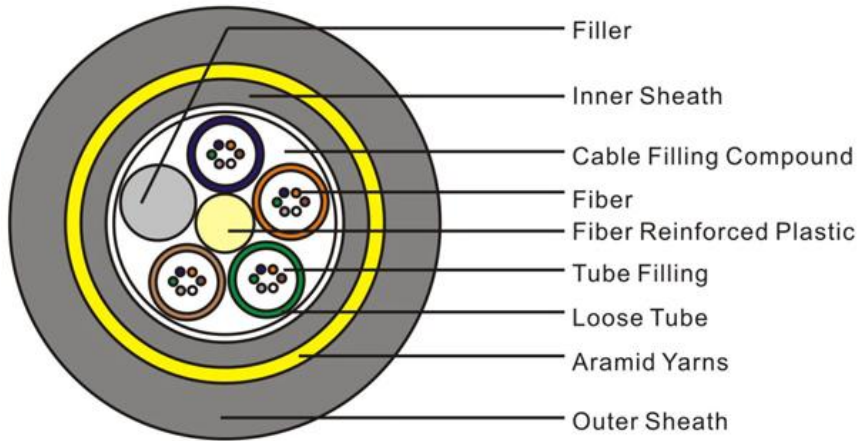

MARKING

Cable Marker every Meter by:

- Project name or project owner
- Year of manufacture
- Type of cable
- Number of fiber
- Cable length

Packing:

- Wooden or plywood drums with protection

Drum Dimension:

- 1.1m*1.1m*0.6m

Delivery Length:

- Standard delivery lengths are 2km/drum

FIBER ATTENUATION

ITEMS	DESCRIPTION	
G.652D	Attenuation@1310	0.36dB/km
	Attenuation@1550	0.22dB/km

CABLE DIMENSION AND CONSTRUCTION

ITEMS	DESCRIPTION	
Optical Fiber	Attenuation@1310	6/12 fiber per tube
Central Strength Member	Material Diameter	Fiber Reinforce Plastic 2.0mm
Loose Tube	Material Diameter Thickness	PBT 2.0±0.1mm 0.35±0.05mm
Water Proofing	-	Cable Filling Compound
Sheath	Material Color Thickness	MDPE(Inner Sheath)/HDPE(Outer Sheath) Black/Yellow Typical 1.10mm (Inner Sheath)/1.50mm (Outer Sheath)
Cable Diameter		Approx. 11.6mm
Cable Weight		Approx. 95kg/km
Fiber Color Code		1-Blue, 2-Orange, 3-Green, 4-Brown, 5-Slate, 6-White
Tube Color Code		1-Blue, 2-Orange, 3-Green, 4-Brown

MECHANICAL AND ENVIRONMENTAL CHARACTERISTICS

ITEMS	TESTING STANDARD	DESCRIPTION
Tensile Strength	IEC 60794-1-E1 Installation Working	Change of Attenuation $\leq 0.10\text{dB}$ 3000N 100N
Crush Resistance	IEC 60794-1-E3 Installation Working	Change of Attenuation $\leq 0.10\text{dB}$ 3000N 1000N
Repeat Bending	IEC 60794-1-E6	Change of Attenuation $\leq 0.10\text{dB}$
Torsion	IEC 60794-1-E7	Change of Attenuation $\leq 0.10\text{dB}$
Water Penetration	60794-1-2-F5	No water leak through the open end in 24 hours (Sample length 3m)
Temperature Range	60794-1-2-F1	-400C-+700C Change of Attenuation $\leq 0.10\text{dB}$
Bending Radius	Static Dynamic	20×Cable Diameter 10×Cable Diameter

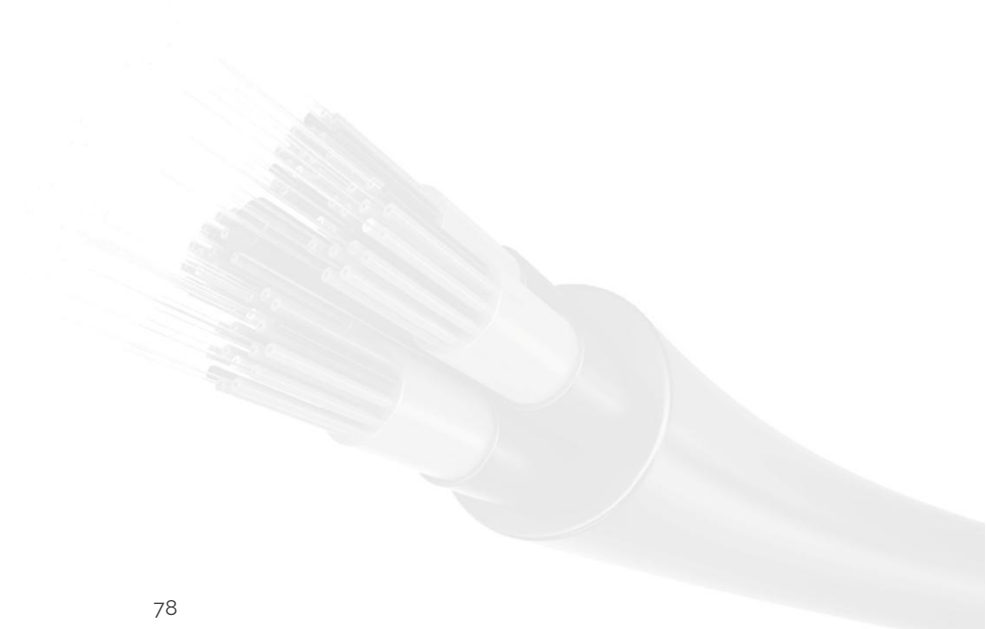

Single Loose Tube Cable 2-24 core

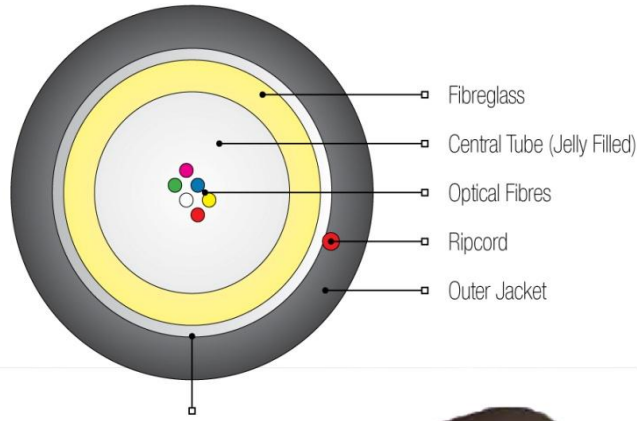

FEATURES

- Choice of fibre type
- Choice of colour coded fibres
- 100% Dielectric
- Water blocking fibreglass reinforcements
- Choice of outer jacket material and colour
- OS2, OM1, OM2, OM3 and OM4

CABLE CHARACTERISTICS

- 250µm colour-coded optical fibre
- Gel filled loose tubes for fibre lubrication and water repelling properties
- Corrugated steel tape for superior protection
- Ripcord
- Durable outer jacket

APPLICATIONS

- Ideal for water crossings e.g. rivers and lakes
- Suitable for one or both end pre-termination

STANDARDS

Environmental and mechanical tests according to: EN 187000 and CEI 60794.

Fire test according to: UNE-EN 50266 (IEC 60332-3) / UNE-EN 50267 (IEC 60754-1) / UNE-EN 50268 (IEC 61034-1/2).

1LSZH = Low-smoke Zero-halogen flame retardant thermoplastic compound

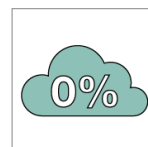

low-smoke
zero halogen



flame retardant



moisture
protected

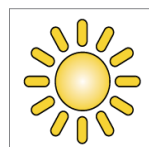

ultraviolet
resistant

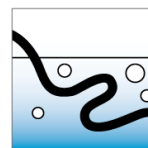

watertight



rodent
protection

Fibre Colour Options:

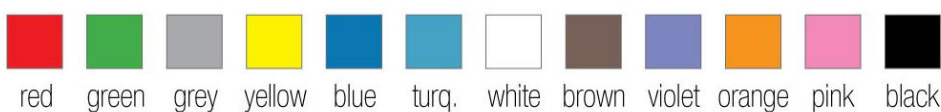

STA Loose Tube Cable 2-24 core

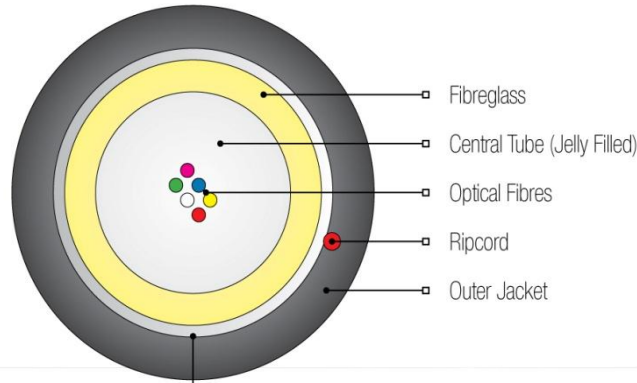

FEATURES

- Choice of fibre type
- Choice of colour coded fibres
- High strength aramid-yarn strength member
- Choice of outer jacket material and colour
- OS1, OM1, OM2, OM3 and OM4
- Able to withstand impacts and high pressure

CABLE CHARACTERISTICS

- 250µm colour-coded optical fibre
- Gel filled loose tubes for fibre lubrication and water repelling properties
- Corrugated steel tape for superior protection
- Ripcord
- Durable outer jacket

APPLICATIONS

- External duct and direct burial applications
- Harsh environments where impact and crush protection is required
- Ideal for water crossings e.g. rivers and lakes

LOOSE TUBE CABLE (2-24)

Fibre Count		2	4	6	8	12	16	24
Weight	kg/km				~88			
Central Tube	mm				4.5			
Outer Diameter	mm				~9.6			
Tensile Load(LT)	N				1500			
Tensile Load(ST)	N				2700			
Min. Bend Radius		20x Outer Diameters						
Maximum Length	m				2000			
Temperature	°C				-40~+70			
Colour					Black			
Crush Resistance	N				2000			

STANDARDS

Environmental and mechanical tests according to: EN 187000 and CEI 60794

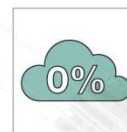

low-smoke
zero halogen

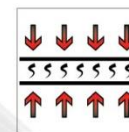

crush resistant



moisture
protected



ultraviolet
resistant



watertight



high rodent
protection

Fibre Colour Options:

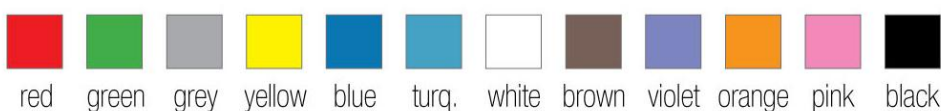

STA Loose Tube Cable 16-144 Fibre

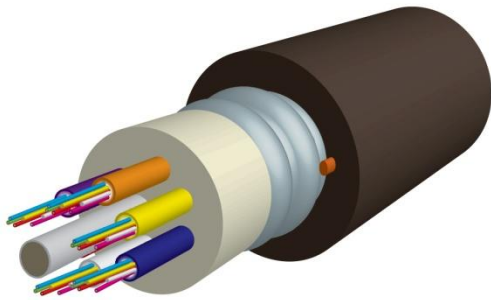
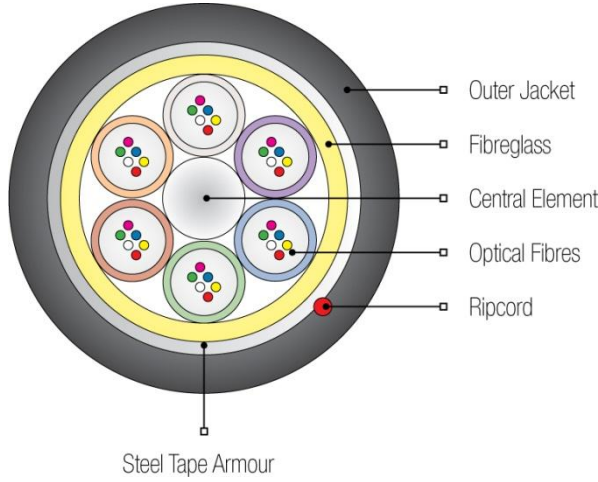

FEATURES

- Choice of fibre type
- Choice of colour coded fibres
- High strength aramid-yarn strength member
- Choice of outer jacket material and colour
- OS1, OM1, OM2, OM3 and OM4
- Able to withstand impacts and high pressure

CABLE CHARACTERISTICS

- 250µm colour-coded optical fibre
- Gel filled loose tubes for fibre lubrication and water repelling properties
- Corrugated steel tape for superior protection
- Central Element (GRP)
- Ripcord
- Durable outer jacket

APPLICATIONS

- External duct and direct burial applications
- Harsh environments where impact and crush protection is required
- Ideal for water crossings e.g. rivers and lakes

MULTI LOOSE TUBE CABLE (16-144)

Fibre Count		16	24	32	36	48	64	72	96	128	144
Fibres/Tube		4	6	8	6	12	8	12	12	8	12
Total Tubes		4	4	4	6	4	8	6	8	18	14
Active Tubes		4	4	4	6	4	8	6	8	16	12
Weight	kg/km	98		143	148		220	215	222	269	261
Outer Diameter	mm	10		12.5			16		18.5		
Tensile Load (LT)	N	2000									
Tensile Load (ST)	N	3600									
Min. Bend Radius		20x Outer Diameters									
Maximum Length	m	4200	3100		2100		3100	2100			
Temperature	°C	-40~+70									
Colour		Black									
Crush Resistance	N	2000									

STANDARDS

Environmental and mechanical tests according to:
EN 187000 and CEI 60794

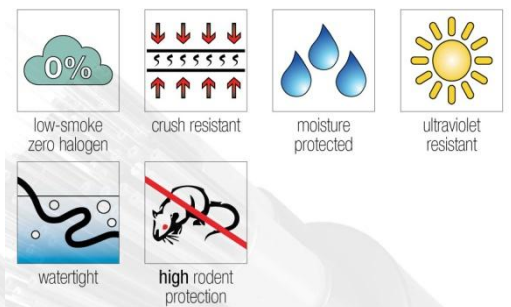

Fibre Colour Options:



Tight Buffered Distribution Cable

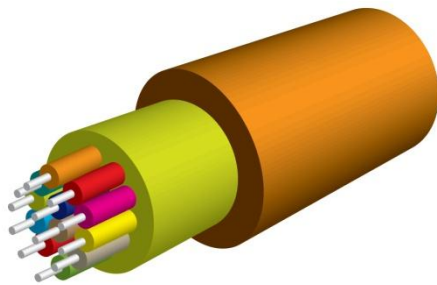
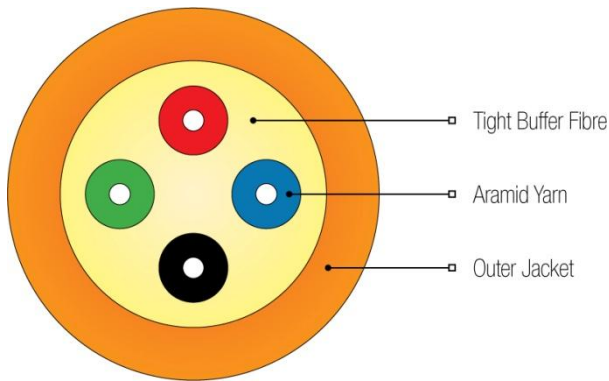

FEATURES

- Choice of fibre type
- Choice of colour coded fibres
- 100% Dielectric
- LSZH outer jacket
- High strength aramid-yarn strength member
- Easy to strip
- Choice of outer jacket material and colour
- OS2, OM1, OM2, OM3 and OM4

CABLE CHARACTERISTICS

- Tight-buffered 900µm optical fibre
- Aramid-yarn strength member
- Durable outer jacket

APPLICATIONS

- Internal cable for installation in trunking, under floor or in ceiling spaces
- Short run external links between buildings
- Fibre backbones in riser and horizontal configurations

TIGHT BUFFERED DISTRIBUTION CABLE

Fibre Core		2	4	6	8	12
Weight	kg/km	19	22	29	37	49
Outer Diameter	mm	4.5	4.9	5.6	6.3	7.3
Tensile Load (LT)	N	300		500		600
Tensile Load (ST)	N	700		850		1200
Min. Bend Radius	20x Outer Diameter					
Maximum Length	m	4200				
Temperature	°C	-5~+60				
Crush Resistance	N	100				

STANDARDS

Environmental and mechanical tests according to: EN 187000 and CEI 60794

Fire test according to: UNE-EN 50266 (IEC 60332-3) / UNE-EN 50267 (IEC 60754-1) / UNE-EN 50268 (IEC 61034-1/2)

1LSZH = Low-smoke zero-halogen flame retardant thermoplastic compound

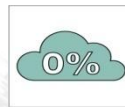

low-smoke
zero halogen



flame retardant



moisture
protected



highly flexible

Fibre Colour Options:



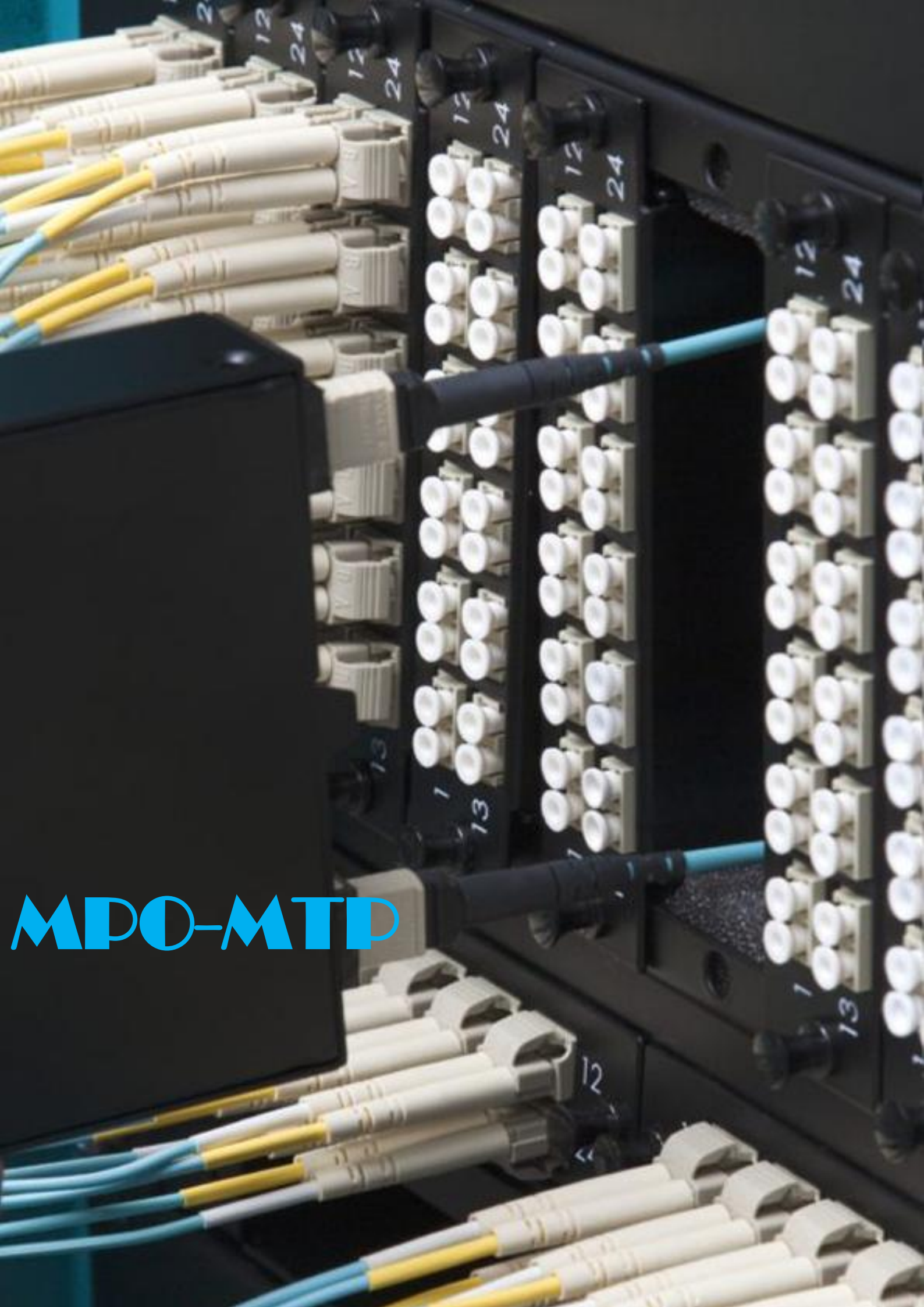

MPO-MTP

High Density 1U MTP Fibre Panel



STRUCTURE DIAGRAM & DESCRIPTION

ICL's High Density 1U Rack is specially designed to facilitate high density cabling systems in Data Centres and Telecommunication environments. This rack-mountable MTP patch panel can be loaded to provide a maximum of 144 fibres, utilising 36 x LC QUAD adapters as well as other capacities (including 72 or 96 fibres) all pre-connectorised to either 12 or 24 fibres MTPs, within a space-saving 1U profile.

Internally, the panel is spliced out to twelve MPO/MTP connectors, providing an easy plug-and-play option for such high-density fibre applications. The 1U fibre Ultra-Slim configuration contains factory controlled and tested MPO/MTP-LC assemblies to deliver optical performance and reliability. Low loss MPO/MTP and LC Premium versions are offered, featuring significantly improved insertion losses for demanding low power budget, high-speed networks.

FEATURES

- Flat front 1U and up to 144 LC fibre port configuration
- Available in SM, OM1, OM2, OM3, OM4 and OM5 fiber grades
- Flat front panel for optimal cable routing
- Easily accessible MPO/MTP ports for connection to trunk cables
- Compliant IEC-61754-7, EIA/TIA-604-5 & RoHS
- Factory terminated and tested
- MPO/MTP components feature superior optical and mechanical properties

PORT CONFIGURATION IS PROVIDED BY UTILISING LC QUAD & LC DUPLEX ADAPTERS TO ENABLE FIBRE CAPACITIES AT THE FRONT & 24/12 MPO/MTP ADAPTERS AT THE REAR.



MTP/MPO 4-Slot Cassette Open Panel

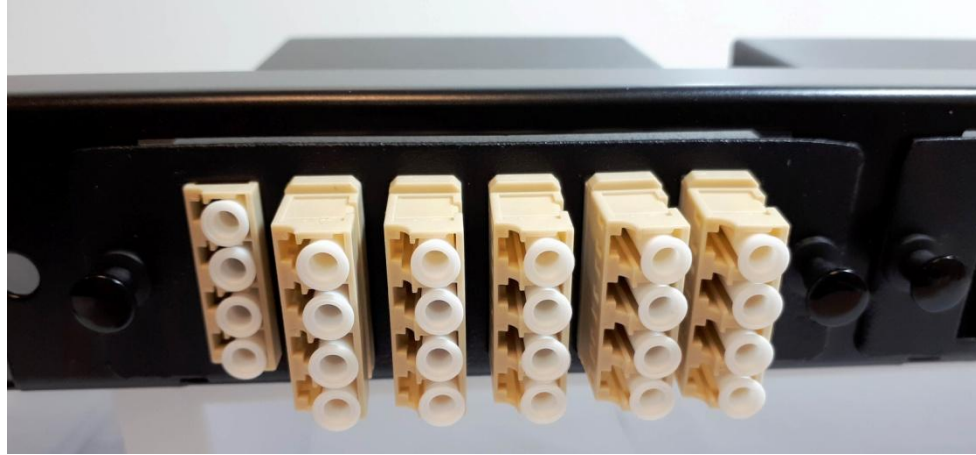

STRUCTURE DIAGRAM & DESCRIPTION

Our new rack-mounted 19" 1U panel is efficient and space-saving, offering 4 open ports, which can be loaded with MTP/MPO cassettes, fibre modules, or for copper applications a RJ CAT6/CAT5e-4-port module.

The panel offers a series of integrated cable retention lugs on the back, which helps secure data cables. The unit is robustly constructed from 16-gauge cold rolled steel, with a powder-coated finish.

FEATURES

- High density panel, supporting 4 x Cassettes, with a total fibre capacity of 96 fibres
- Each cassette has a capacity of 24 fibres
- All cassettes are pre-terminated
- Cassettes can be configured with 2 x 12-fibre MTP/MPO, or a single 24-fibre MTP/MPO Circuit
- Simple assembly and installation, cassettes are mounted to the panel separately
- Remaining open ports can be blanked off
- Dimensions = 440x190x43mm



MTP/MPO 12 Cassete 2U Rack



STRUCTURE DIAGRAM & DESCRIPTION

ICL's 2U rack-mounted MPO/MTP panel has a capacity for up to 12 vertically stacked MPO/MTP cassettes.

FEATURES

- Room for up to 12 MPO/MTP cassettes
- 2U height
- Cable management bar for easy organisation of fibre cable
- Cold rolled steel material
- Durable powder coated finish



MTP/MPO Max Fibre Cassette



STRUCTURE DIAGRAM & DESCRIPTION

Ideal for interconnecting multifibre MTP/MPO trunk cables and splitting the fibres out to various patching cables. Each cassette is internally populated with LC terminated breakout fibres. The cassettes are designed for fast and easy installation into ICL's 4 slot cassette open panel, alternatively into a 2U rack-mounted MPO/MTP panel.

Available in multimode OM3/OM4/OM5 and singlemode. The cassettes can be assembled as a single MTP/MPO 24-fibre unit, interfacing to 6 x LC Quad Adapters, or 2 x 12-fibre MTP/MPO internal circuits, directly terminated into 2 groups of LC.

FEATURES

- LC flangeless QUAD adapters
- Pre-terminated MTP/MPO, available as a 24-fibre single circuit or 2 x12-fibre circuits
- Easy nylatch panel fixing fasteners
- Robust plug & play cassettes



Mini Keystone 4-Port

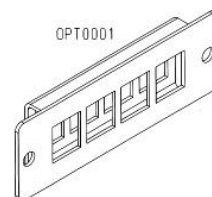
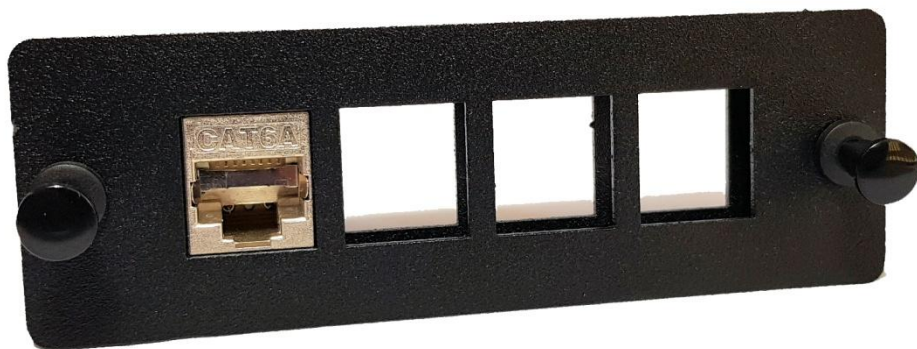

STRUCTURE DIAGRAM & DESCRIPTION

ICL's Mini Keystone4-Port RJ Adapter complements our MPO/MTP 4 cassette and the higher density 2U rack-mounted MPO/MTP 12 cassette panel.

The adapter place is manufactured from cold rolled steel and painted with black powder-coated finish. The adapter simply locks into position by snap-lock rivets.

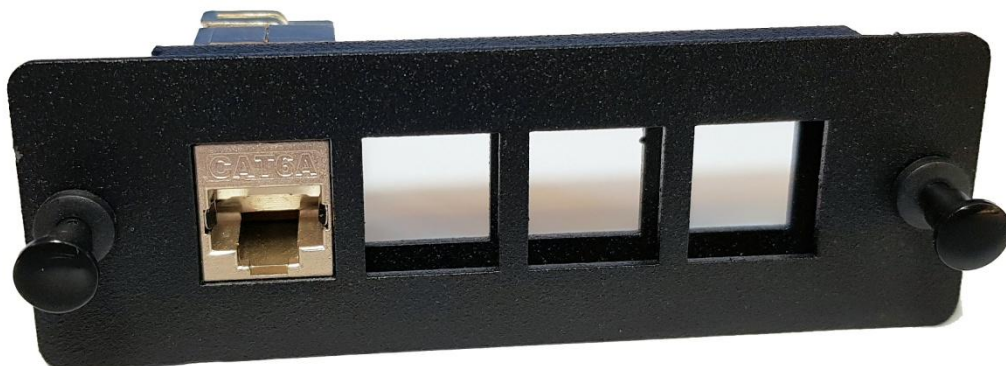

QSFP MTP/MPO – LC Duplex Breakout Cable

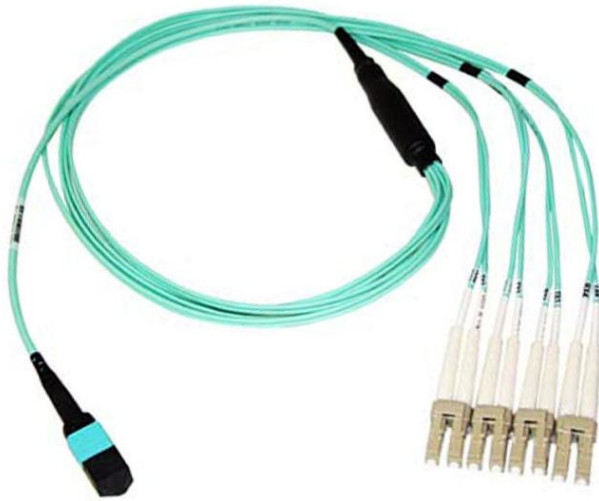

STRUCTURE DIAGRAM & DESCRIPTION

This is a 40 Gigabit Ethernet QSFP 40GBase-SR4 to MTP (MPO) / LC (4 LC Duplex) varied length breakout cable, OM3, 50/125. The GBIT QSFP MTP to LC/UPC breakout cable uses 12 fibre MMF 50/125um OM3 fibre (middle 4 fibres are unused).

It connects to a QSFP module cable for a fan out and offers an aqua/turquoise jacket colour. The fan out side has 8 LC Duplex connectors that are numbered according to the fibre position in the MTP/MPO connector.

FEATURES

- Connector A) MPO female connector (No guide pins)
- Connector B) LC/UPC
- 40 GB pin-out configuration
- Jacket type: LSZH rated (OFNR)
- Jacket colour: Aqua
- Fibre mode: multimode 50 laser optimised OM3
- Lengths available on request
- Cable type: 3mm round to 2mm on the breakout side
- Fibre count: 8 fibres

TECHNICAL DRAWING

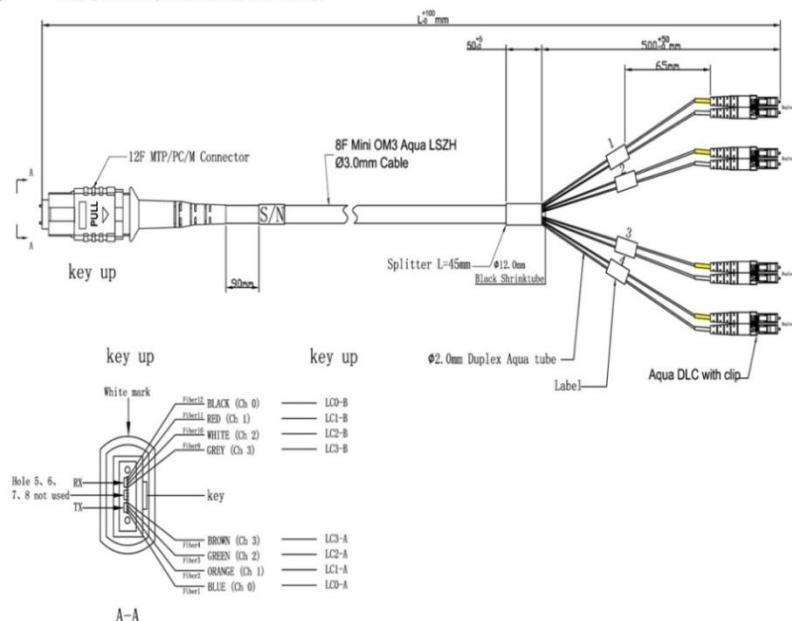

A close-up photograph of a fiber optic patch panel. The panel is filled with hundreds of fiber optic cables, organized into neat rows. The cables are color-coded, with yellow and pink being the most prominent. They are held in place by blue plastic clips on a metal frame. The background shows a rack of network equipment with green and pink ports.

FIBRE MANAGEMENT

Breakout Wallbox 6 Port SC Duplex/LC QUAD



STRUCTURE DIAGRAM & DESCRIPTION

This terminal box terminates up to 24 fibres. It is a perfect cost-effective solution for FTTx networks. It features a solid construction with adapter ports located on the outside edge for easy access.

FEATURES

- 1.2mm mild steel, IP20-rated
- 1x 20mm cable gland and 4x bunny clips
- Can be supplied unloaded or preloaded
- Ideal use indoor data centres or telco network
- Dimensions (L×W×H): 110mm × 110mm × 45mm

Breakout Wall Box - 8 Port FC/ST



STRUCTURE DIAGRAM & DESCRIPTION

This terminal box terminates up to 8 fibres. It is a perfect cost-effective solution for FTTx networks. It features a solid construction with adapter ports located on the outside edge for easy access.

FEATURES

- 1.2mm mild steel, IP20-rated
- 1x 20mm cable gland and 4x bunny clips
- Can be supplied unloaded or preloaded
- Ideal use indoor data centres or telco network
- Dimensions (L×W×H): 110mm × 110mm × 45mm

Breakout Wall Box 8 Port SC Simplex/LC Duplex



STRUCTURE DIAGRAM & DESCRIPTION

This terminal box terminates up to 16 fibres. It is a perfect cost-effective solution for FTTx networks.

FEATURES

- 1.2mm mild steel, rated at IP20
- 1x 20mm cable gland and 4x bunny clips
- Can be supplied unloaded or preloaded
- Ideal use indoor data centres or telco network
- Dimensions (LxWxH): 160mm x 160mm x 45mm



Tamper Proof Wall Box - 8-Port ST/FC



STRUCTURE DIAGRAM & DESCRIPTION

This terminal box terminates up to 8 fibres. It is a perfect cost-effective solution for FTTx networks. It features a solid construction, with adapter ports located on the outside edge for easy access.

FEATURES

- 1.2mm mild steel, rated at IP20
- 1x 20mm cable gland and 4x bunny clips
- Can be supplied unloaded or preloaded
- Ideal use indoor data centre or telco network
- Dimensions (LxWxH): 110mm x 110mm x 45mm

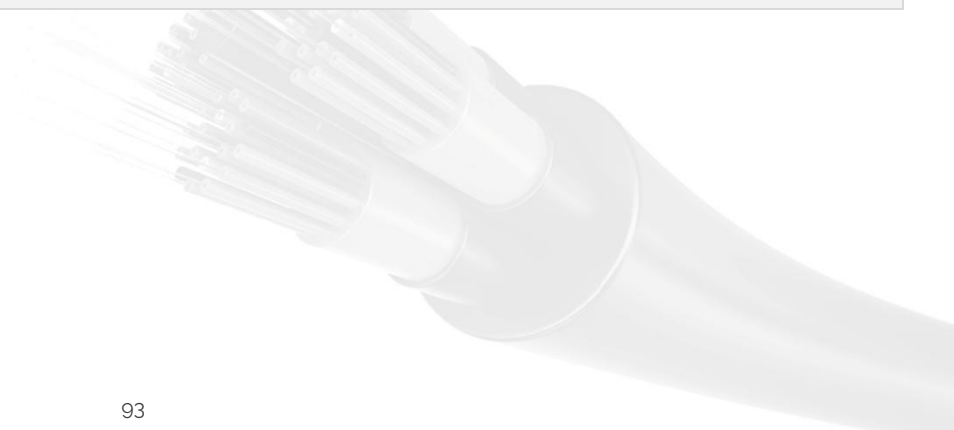

DIN Mountable Breakout Distribution Box

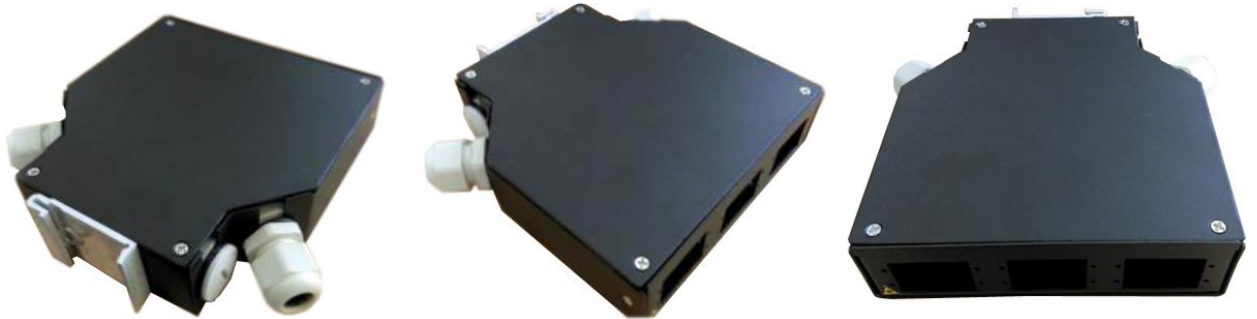

STRUCTURE DIAGRAM & DESCRIPTION

DIN Mountable Breakout Distribution Box (for 6 x SC Duplex/LC QUAD) and its larger counterpart (for 12 x SC Simplex/LC Duplex) can be used for various fiber optic networks within a rack. If space is limited, both can be wall-mounted using a suitable mounting rail. The units are suitable for terminal connection/patching/distribution for smaller networks and various other applications.

FEATURES

- Cold-rolled steel with electrostatic coating
- Suitable for different adapters: FC, SC, ST, LC
- 4x cable entry/exit ports; 12x pigtail entry/exit ports
- 12 fibre internal splicing module
- Maximum 12 port capacity

APPLICATIONS

- Suitable for pigtail, ribbon and bulk cable distribution
- Wall-mounted
- Rack-mounted
- Used in FTTH, Telecommunications and CATV etc.



6 x SC Duplex/LC QUAD
(129 x 37 x 140 mm)



12 x SC Simplex/LC Duplex
(145 X 123 X 72 mm)

IP56 Box

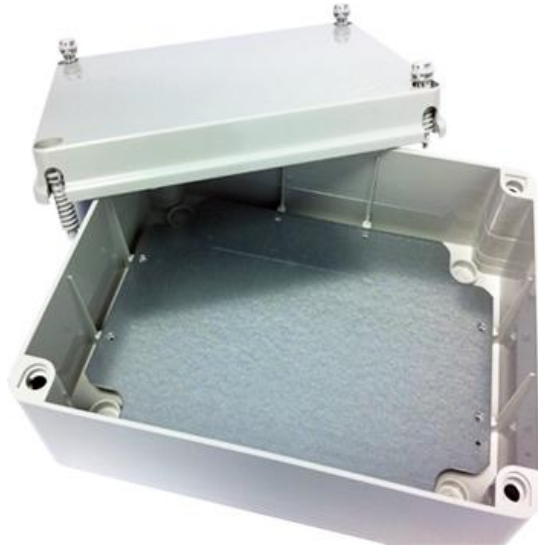

STRUCTURE DIAGRAM & DESCRIPTION

Our range of IP rated wall boxes is constructed to comply with the IP56 level of the ingress protection rating scheme. The boxes can either be supplied as unloaded (no adapters) or supplied with the adapters of your choice and/or a simple splice management kit. Maximum adapter capacity is up to 24 x FC/ST, 12 x SC Duplex or 12 x LC QUAD adapters.

TECHNICAL SPECIFICATIONS

- Width: 200mm
- Depth: 110mm
- Height: 260mm
- Color: Grey RAL 7035
- Cable entry: 2 x 20mm gland holes

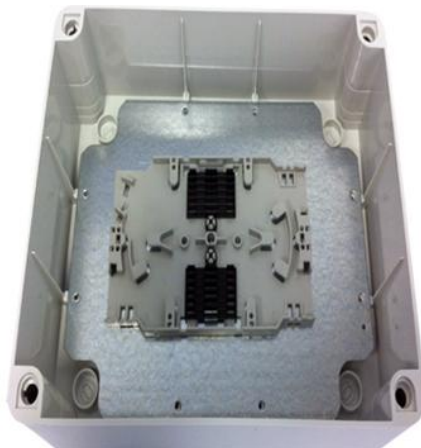
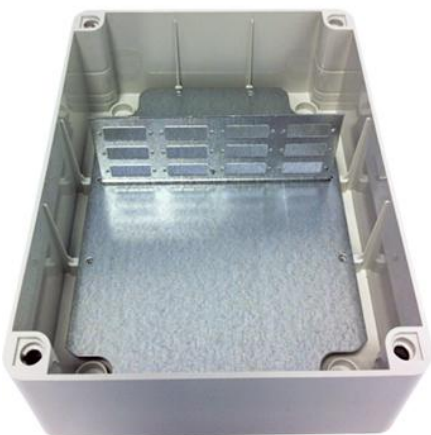

Sliding SC Simplex / LC Duplex Patch Panel (24 ports)



STRUCTURE DIAGRAM & DESCRIPTION

The 1U rack-mounted sliding panel is available unloaded or pre-loaded with up to 24 SC Simplex or LC Duplex multimode or singlemode adapters. It features 4x 20mm cable entry/exit holes, and 2x 10mm blown fibre holes. The panel's lower tray features punched slots for securing our fibre management trays, and pressed loops for securing fibre in place. The panel is constructed from cold-rolled steel, and finished with a durable matte black powder-coating. Other finishes such as grey powder-coating and natural stainless steel are also available.

FEATURES

- SC Simplex / LC Duplex
- Maximum fibre capacity equal to 48 fibres (LC Duplex)
- Fixed and sliding configurations
- Colour finish – black, RAL 9005
- RoHS compliant
- Operating temperature to -25°C +40°C
- Weight 2.59kg
- Supplied with fibre management kit

SPECIFICATIONS

Compatible adapters	SC Simplex / LC Duplex, MTRJ
19 inch rack fitting	1U
Weight (empty)	1.9kg
Weight (packaged)	2.5kg
Cable entry	4x 20mm, 2x 10mm
IP Rating	IP20
Material	16 gauge cold-rolled steel
Dimensions (panel only)	W: 424mm; H:44mm; D: 222mm

Sliding SC Simplex / LC Duplex Patch Panel (24 ports)



FRONT PLATE

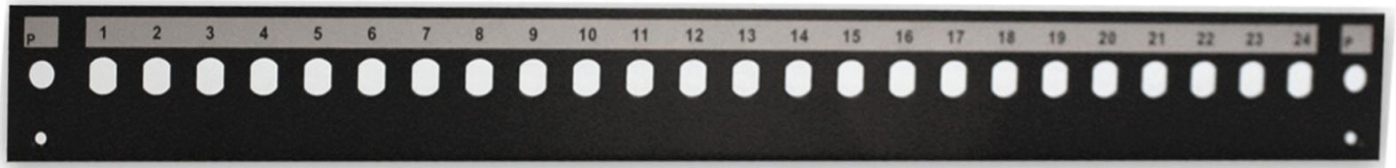

SC SIMPLEX / LC DUPLEX / MTRJ

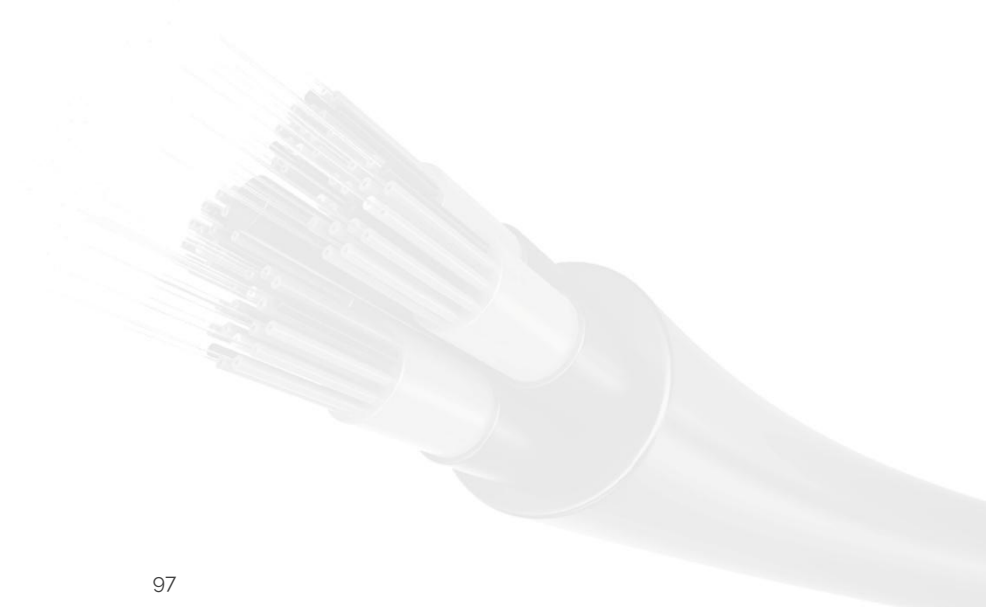

Sliding SC Duplex / LC QUAD Patch Panel (24 ports)



STRUCTURE DIAGRAM & DESCRIPTION

The 1U rack-mounted vertical sliding panel is available unloaded or pre-loaded with up to 24 SC Duplex or LC QUAD multimode or singlemode adapters. It features 4x 20mm cable entry/exit holes, and 2x 10mm blown fibre holes. The panel's lower tray features punched slots for securing our fibre management trays, and pressed loops for securing fibre in place. The panel is constructed from cold-rolled steel, and finished with a durable matte black powder-coating. Other finishes such as grey powder-coating and natural stainless steel are also available.

FEATURES

- SC Duplex / LC Quad
- Maximum fibre capacity equal to 96 fibres (LC Quad)
- Fixed and sliding configurations
- Colour finish – black, RAL 9005
- RoHS compliant
- Operating temperature to -25°C +40°C
- Weight 2.59kg
- Supplied with fibre management kit

SPECIFICATIONS

Compatible adapters	SC Duplex / LC QUAD
19 inch rack fitting	1U
Weight (empty)	1.9kg
Weight (packaged)	2.5kg
Cable entry	4x 20mm, 2x 10mm
IP Rating	IP20
Material	16 gauge cold-rolled steel
Dimensions (panel only)	W: 424mm; H:44mm; D: 222mm

Sliding SC Duplex / LC QUAD Patch Panel (24 ports)



FRONT PLATE

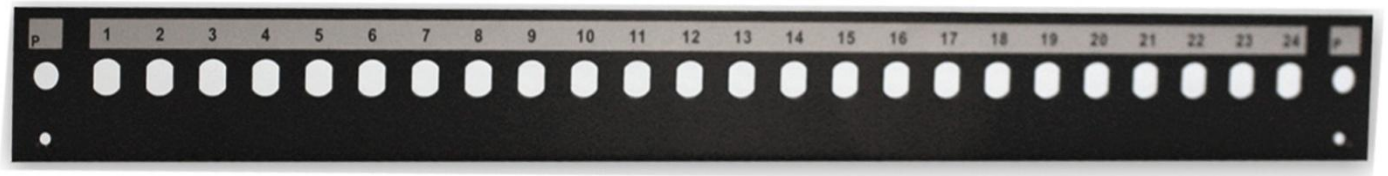

SC Duplex / LC QUAD

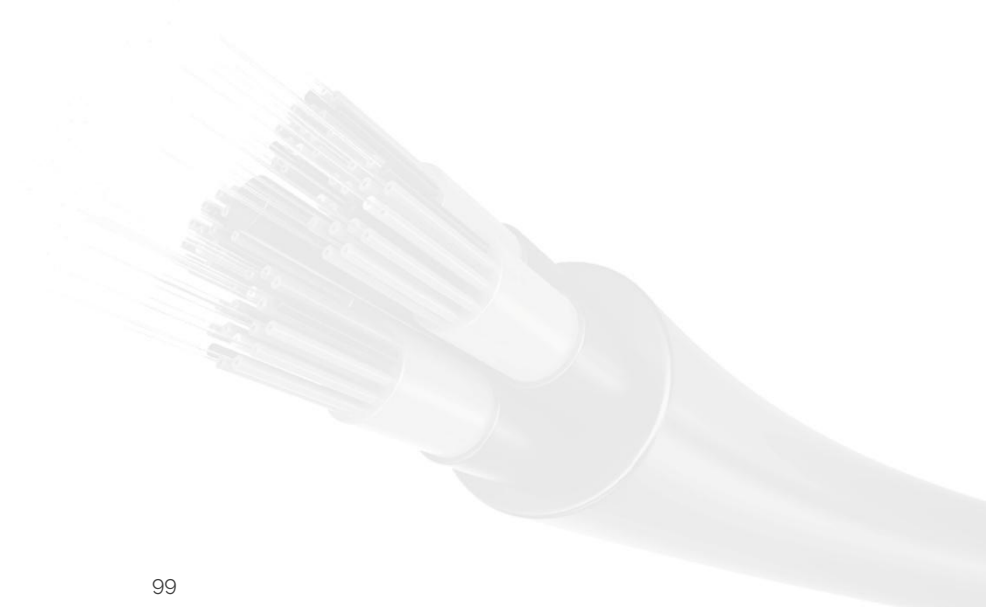

Sliding FC / ST Patch Panel (24 ports)



STRUCTURE DIAGRAM & DESCRIPTION

The 1U rack-mounted sliding panel is available unloaded or pre-loaded with up to 24 FC or ST multimode or singlemode adapters. It features 4x 20mm cable entry/exit holes, and 2x 10mm blown fibre holes. The panel's lower tray features punched slots for securing our fibre management trays, and pressed loops for securing fibre in place. The panel is constructed from cold-rolled steel, and finished with a durable matte black powder-coating. Other finishes such as grey powder-coating and natural stainless steel are also available.

FEATURES

- FC / ST
- Maximum fibre capacity equal to 24 fibres (LC Quad)
- Fixed and sliding configurations
- Colour finish – black, RAL 9005
- RoHS compliant
- Operating temperature to -25°C +40°C
- Weight 2.59kg
- Supplied with fibre management kit

SPECIFICATIONS

Compatible adapters	24x ST/FC
19 inch rack fitting	1U
Weight (empty)	1.9kg
Weight (packaged)	2.5kg
Cable entry	4x 20mm, 2x 10mm
IP Rating	IP20
Material	16 gauge cold-rolled steel
Dimensions (panel only)	W: 424mm; H:44mm; D: 222mm

Sliding FC / ST Patch Panel (24 ports)



FRONT PLATE

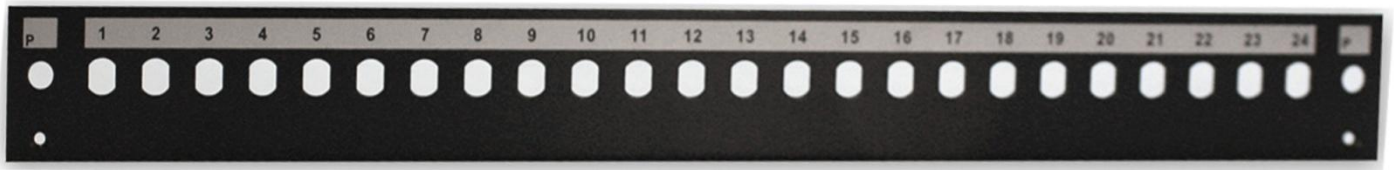

FC/ST



2U Fixed Patch Panel



STRUCTURE DIAGRAM & DESCRIPTION

Our 2U rack-mounted vertical fixed patch panel is available unloaded or pre-loaded with up to 48 x SC Duplex or 48 x LC QUAD adapters (singlemode / multimode). The panel's lower tray features punched screw holes for securing our fibre management trays and pressed loops for securing fibre in place. The panel is constructed from cold-rolled steel and finished with a durable matte black powder coating. Other finishes, such as a grey powder coating and natural stainless steel are also available.

FEATURES

- Fixed lid style, giving greater security
- SC-Duplex, LC-QUAD Adapters
- Fibre capacity: 96 fibre (SC Duplex); 192 fibre (LC QUAD)
- Colour finish - black, RAL 9005
- RoHS compliant
- Supplied with fibre management kit

SPECIFICATIONS

PARAMETERS	CHARACTERISTICS
Compatible adapters	48x SC Duplex/LC Quad
19 inch rack fitting	U - 2
Weight (empty)	3.7 kg
Weight (packaged)	3.8 kg
Cable Entry	4 x 20mm
IP Rating	IP20
Material	16 gauge cold-rolled steel
Dimensions (panel only)	W: 440mm; H:44mm; D:300mm



48-Port Telescopic ODF



STRUCTURE DIAGRAM & DESCRIPTION

48-Port Telescopic ODF is constructed from cold-rolled steel with integrated fibre routing and splice management. The 19" Panel is suitable for single fibre pigtail applications or ribbon splicing and includes a self-locking sliding mechanism function, which prevents drawer slippage.

FEATURES

- Standard 19" rack-mounted with solid construction
- Telescopic sliding drawer tray for easy access
- Options for FC, SC, ST and LC adapter plates
- Front access panel is designed for easy operation
- Suitable for 19" or optionally 23" distribution cabinets
- Metal lid
- 4 x splice trays
- 6 x adapter plates (8 ports per plate)
- Max capacity 48 ports (can be adapted to 96 fibres with LC Duplex and double stacking splices)
- 4 fibre cable entry ports at rear
- Available in black or white



APPLICATIONS

- Telecommunications
- Fibre to the home (FTTH)
- LAN / WAN
- CATV

DIMENSIONS

Fiber Quantity	Dimension (mm)	Net Weight (kg)
48	482*328*100	7.7



ICL IP Metal Single-Door Lockable Wall Box



STRUCTURE DIAGRAM & DESCRIPTION

The ICL Metal Single-Door Lockable Wall Box features an adapter-ready internal bracket and splice tray option. Adapters, splice trays and pigtails can be installed upon request. The façade is constructed from cold-rolled steel with a highly durable electrostatic powder coating.

SPECIFICATIONS

Dimensions (H x W x D)	mm	270 x 227 x 50
Weight	kg	1.8
Cable Entry/Exit	2 x 20mm	
Operating Temperature	°C	-40 ~ +60
IP rating	IP20	
Adapter Options	FC, LC, SC simplex, SC duplex, ST	
Material	Cold rolled steel	

FEATURES

- IP20 rating
- Tamper-proof construction
- Secure internal bracket for adapters (see specs)
- U-shape cut-outs for easy cable entry/exit
- Secure lock: two keys provided
- Splice bridge available upon request
- RoHS compliant
- TIA/EIA 568.C, ISO/IEC 11801, EN 50173, IEC 60304 IEC 61754, EN 297-1



Double Door Lockable Wall Box



STRUCTURE DIAGRAM & DESCRIPTION

Our IP20-rated double door lockable wall boxes provide a very cost-effective and secure way to terminate fibre optic cables and are a great alternative to standard 19" data cabinets or patch panels. The quality of construction of our range of wall boxes is second to none and can be configured with the adaptors and accessories of your choice.

SPECIFICATIONS

PARAMETERS	CHARACTERISTICS
Height	380mm
Width	330mm
Depth	72mm
Net weight	3.2kg
Packaged weight	3.5kg
Package Dimensions	-345mm (W) X 395mm (L) X 80mm (D)
IP rating	IP20
Suitable for adaptor type	ST/FC, SCD/LCQ, SCS/LCD
Number of doors	2
Cable entry 20mm	4
Material	Cold rolled steel
Material thickness	1.2mm
Material coating	Electrostatic powder coating
Color	White
Operating Temperature	-40°C to + 60°C
Compliant to	RoHS, Reach, SVHC
Designed in accordance with	TIA/EIA 568.C, ISO/IEC 11801, EN 50173, IEC 60304, IEC 61754, EN 297-1



Dome Closure (IP68-Rated)



STRUCTURE DIAGRAM & DESCRIPTION

Our dome enclosure is convenient to install and does not require special tooling. It is suitable for aerial, underground, wall-mounting, manhole-mounting and duct-mounting applications. Made from injection moulded, high-strength engineered PC plastic; it is resistant to damage caused by extreme temperatures and ultraviolet radiation. Features a compartment tray to store excess fibres.

FEATURES

- Solid and secure
- Sealing: heat shrinkable sealant
- Cable entry & exit: 4 x circular, 1 x oval
- Fibre management trays

SPECIFICATIONS

PARAMETERS	CHARACTERISTICS
Dome and base material	PP alloy
Tray material	ABS
Dimensions inc. lid (LxD)	450mm x 230mm
Max. capacity	120C
Atmospheric pressure	70~106 Kpa
Environment temperature	-40°C to +85°C



Dome Fibre Optic Splice Closure

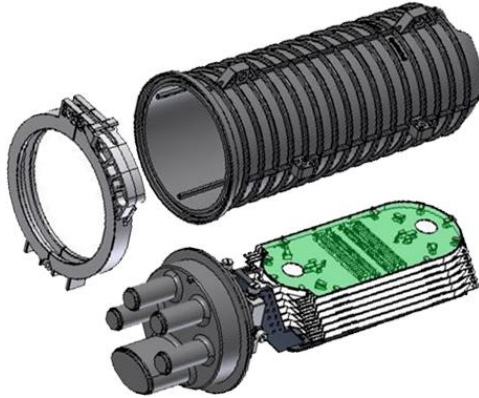

Fiber Optic Splice Tray
1-4 pieces with 6 or 12 fibres per tray

Total Capacity (fibers)
24 or 48

Dimension (HxD) mm
300 X 188

Cable Entry & Size
1 large oval port with dia.14x28 mm 4 round ports with dia.16mm

STRUCTURE DIAGRAM & DESCRIPTION

Our fibre optic splice closures are specially designed to protect optic cable joints. Excessive fibres can be stored in storage baskets behind the splice trays. The optical fibres are taken into the middle of splice trays. One tray can accommodate up to 12 fibre splices, a closure can accommodate up to 4 trays. The dome material has anti-corrosion and anti-aging properties and provides ultraviolet protection.

FEATURES

- Excessive fibres can be stored in storage baskets
- Material has anti-corrosion and anti-aging properties and provides ultraviolet protection
- Base-to-dome seals on closure are mechanical and heat-shrinkable for ease of installation
- Base and dome are sealed with clamp and O-ring system
- The splice trays are hinged for easy access (without disturbing other trays)
- Built in earthing point protects from lightning damage
- The internal and fixing parts are made of stainless steel
- Compatible with most cable types
- No special tools are needed to open the closure, and it can be opened and used repeatedly

TECHNICAL PARAMETERS

- Working temperature: -40°C~ to +70°C
- Atmospheric pressure: 70~150 Kpa
- Axial tension: >2000N/1min
- Stretching resistance: 2500N/10 square centimetre (1min)
- Insulation resistance: >2*10⁴MΩ
- Voltage strength: 15KV/1min, no arc over or breakdown
- Pressure test: 50m/72hours
- Splice tray with optical bend radius ≥ 40mm
- Low optical loss
- Certification: CE, RoHS, ISO 9001: 2000, ISO 14000, TLC
- Cable entry port: 4 round ports and 1 oval port

SPECIFICATIONS

The durable housing has fire-resistant, anti-aging and waterproof qualities. Designed to be flexible, it has a highly reliable heat shrink sealing system.

CHARACTERISTICS

Used in straight-through and branching applications. Suitable for aerial, underground, direct burial, wall-, manhole- and duct-mounting applications.

Connector Adapter Dome Enclosure (IP68-Rated)

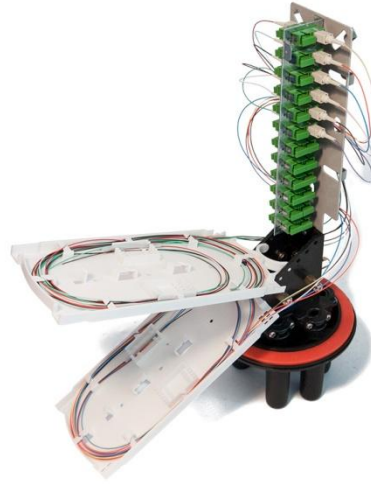

STRUCTURE DIAGRAM & DESCRIPTION

A traditional dome enclosure featuring a unique internal structure, designed for an adapter connector solution as an alternative to the fusion splicing system. This unique closure features a strong and secure metal internal plate with a fiber management system in the rear.

FEATURES

- Material: PC
- Unique connector-adapter system
- Solid and secure
- Sealing structure: heat shrinkable sealant
- Environment temperature: -40°C to +85°C
- Atmospheric pressure: 70~106Kpa

SPECIFICATIONS

- Dimensions (including lid): Diameter:220mm; Height: 510mm

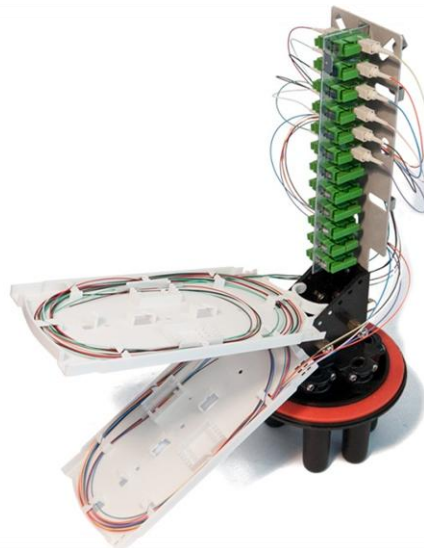

Mechanical Sealing Dome Closure



STRUCTURE DIAGRAM & DESCRIPTION

Our mechanical sealing dome closure is suitable for aerial, underground, wall-, manhole- and duct-mounting applications. Made from injection moulded, high-strength engineered PC plastic; it is resistant to damage caused by extreme temperatures, and ultraviolet radiation. It features a compartment tray to store excess fibres. A variety of port configurations are available, each made of customised vulcanised rubber.

FEATURES

- Anti-aging material which is resistant to ultraviolet radiation
- Mechanical base-to-dome seals facilitate installation and re-entry
- Base and dome sealed with clamp and O-ring system
- Splice trays are hinged for access to any single splice without disturbing other splice trays
- Stainless steel internal and fixing parts
- An earthing device protects the closure from lightning damage
- Compatible with most cable types and cable constructions

SPECIFICATIONS

Dome and base material	PP alloy
Tray material	ABS
Dimensions inc. lid (LxD)	540mm x 180mm
Max. capacity	96 fiber
Capacity for each tray	24 fibres
4 round ports with diameter	18.5mm
1 large round port	40mm
Available cable diameter	from 3mm to 17.5mm
Splice position	in the middle or on the sides



Mass-Fibre Count Dome Closure

STRUCTURE DIAGRAM & DESCRIPTION

The OPTi-Dome Mass-Fibre Dome Closure is a single ended Multi-Entry environmentally sealed enclosure for External Plant Fibre Splicing and Network Integration. Suitable for Aerial, burial and Over-Hang catenary installations and applications.

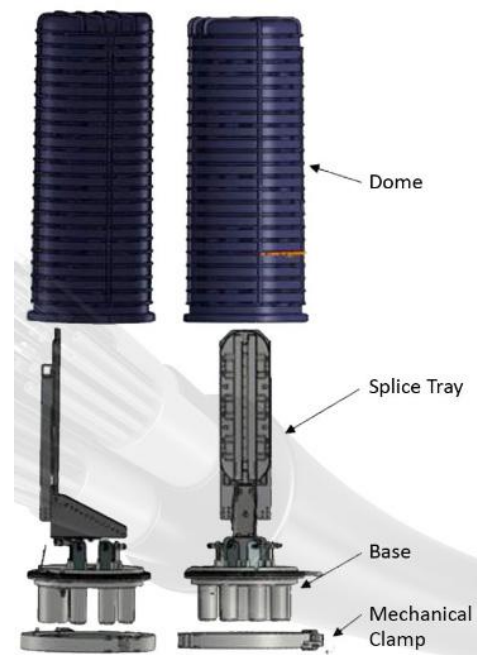

FEATURES

- Base unit and Dome cover are sealed with a clamp and Silicon O-ring system
- 5 round cable entries (Dia.5 x35mm) + 1 oval port (10x25mm) are provided
- Max. Capacity: 72 x 8 equaling 576 Fibres (Capacity, 72-fibres per tray)
- Dimensions: Height = 680mm – Diameter = 305mm
- Material: PP
- The Enclosure can be utilised and installed in aerial, over-ground and underground environments.
- Cable entry-exit sealing: Via Heat-Shrinkable sealing

TECHNICAL PARAMETERS

- Working temperature: -40°C to +65°C
- Atmospheric pressure: 70-106Kpa
- Axial tension: > 1000N/1min
- Rigidity resistance: 2000N/10 square centimeter (1 min)
- Insulation resistance: >2x104MΩ
- Voltage resistance: 15KV(DC)/1 min, with no arc-over or breakdown
- Temperature cycles: -40°C to +70°C, with an inner pressure of 60(+5)kPa, over 10 Cycle periods the decrease of pressure not exceeding 5kPa at room temperature
- Durability: 25-years
- IP rating to IP68

Multiport Dome Enclosure with Direct SC Termination



STRUCTURE DIAGRAM & DESCRIPTION

The multiport dome enclosure is based on a combination closure which has a provision for splicing (utilising traditional splice methods) as well as a separate provision for 16 x SC Simplex Ports for direct connector termination. It is typically used for FTTH applications, where each terminated tail is allocated to a specific subscriber.

FEATURES

- Suited for aerial, pole and underground environments
- Base and dome are sealed with a clamp and O-ring system
- 2 round cable ports (apply cable dia.4~12mm) and 1 oval port (apply cable dia.10~21mm)
- Mechanical sealing
- Can be used with: 16x SC adapters for drop cable; also 4 pieces of 1x4/2x4, 2 pieces of 1x8/2x8 or 1 piece of 1x16/2x16 micro PLC splitter

SPECIFICATIONS

Material	PP
Dimensions	395mm x 300.6mm x 269mm
Max. capacity	96 fibre (24 x 4pcs)
Max. capacity of splice tray	24 fibres
Working temperature	-40°C ~ +65°C
Atmospheric pressure	70 - 106Kpa
Axial tension	> 1000N/1min
Stretching resistance	2000N/ 10 square centimetre (1 min)
Insulation resistance	>2*104MΩ
Voltage strength	15KV (DC)/1 min, no recover/breakdown
Temperature cycle	-40°C ~ +70°C , Inner pressure: 60(+5)kPa



CYCLE: 10 times, the decrease of pressure can't exceed 5kPa at room temperature

Horizontal Splice Closure 12-96 Fibre (IP68-Rated)

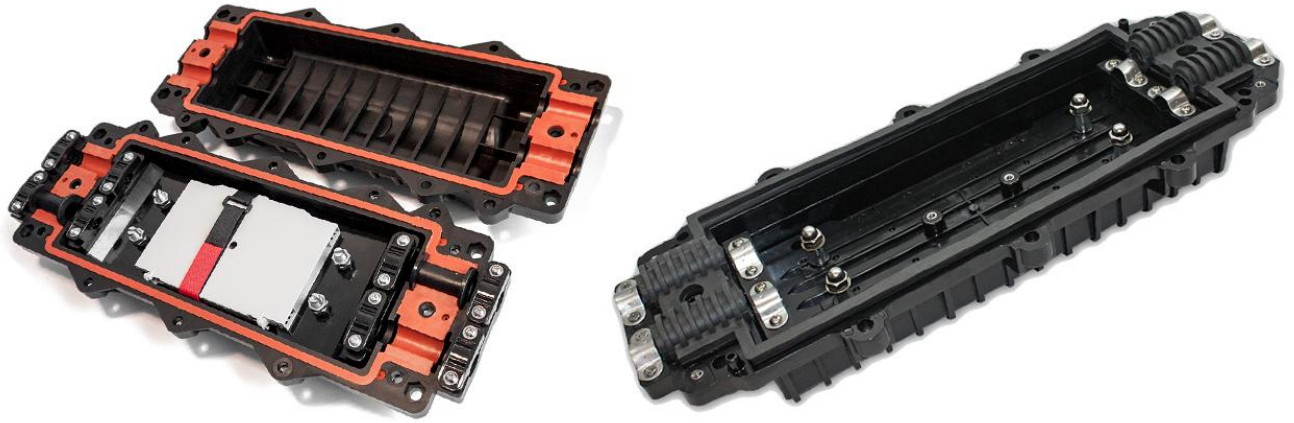

STRUCTURE DIAGRAM & DESCRIPTION

Our horizontal splice closure is designed for straight-through line/branching applications, ensuring protection from the environment and is suitable for underground deployment. Ideal for aerial, underground, wall mounting, duct mounting and manhole mounting.

FEATURES

- Material: PC
- 2 inlet, 2 outlet splice closure
- Fire resistant, waterproof, and quake-proof
- Max. capacity: 96 fibre
- Environment temperature: -40°C to +75°C
- Atmospheric pressure: 70~106Kpa
- Tested and inspected to the highest standards
- Dimensions inc. lid (LxWxH): 605mm x 215mm x 175mm



SPECIFICATIONS

Operating Temperature	-40°C to +65°C
Weight per unit	2.95 kg
Inlet/outlet ports	4 total (2 per side)
Diameter of fiber cable	Φ5—Φ20 (mm)
Max. Closure Capacity	Bunched: 12—96 (Cores)
	Ribbon: max.144 (Cores)
Material	PP

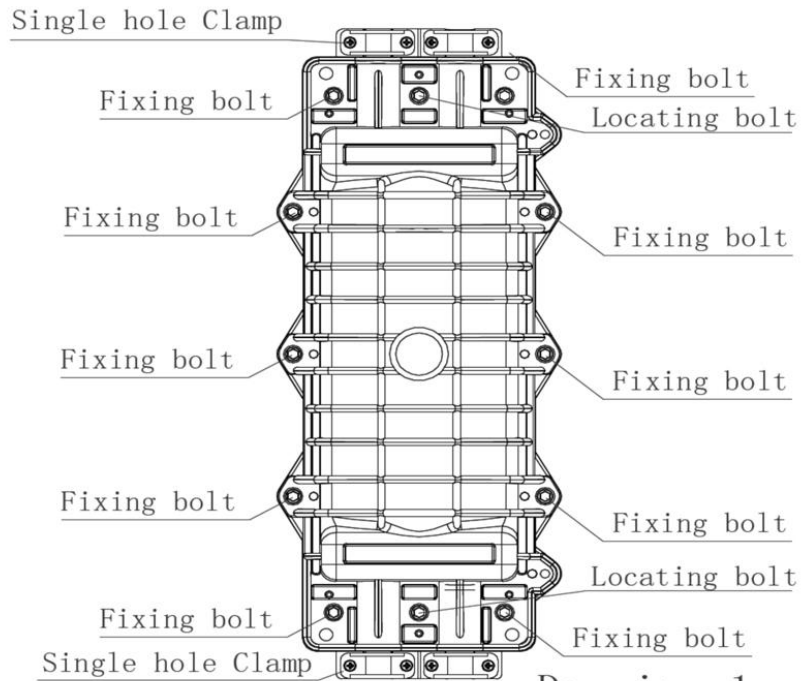

Drawing 1

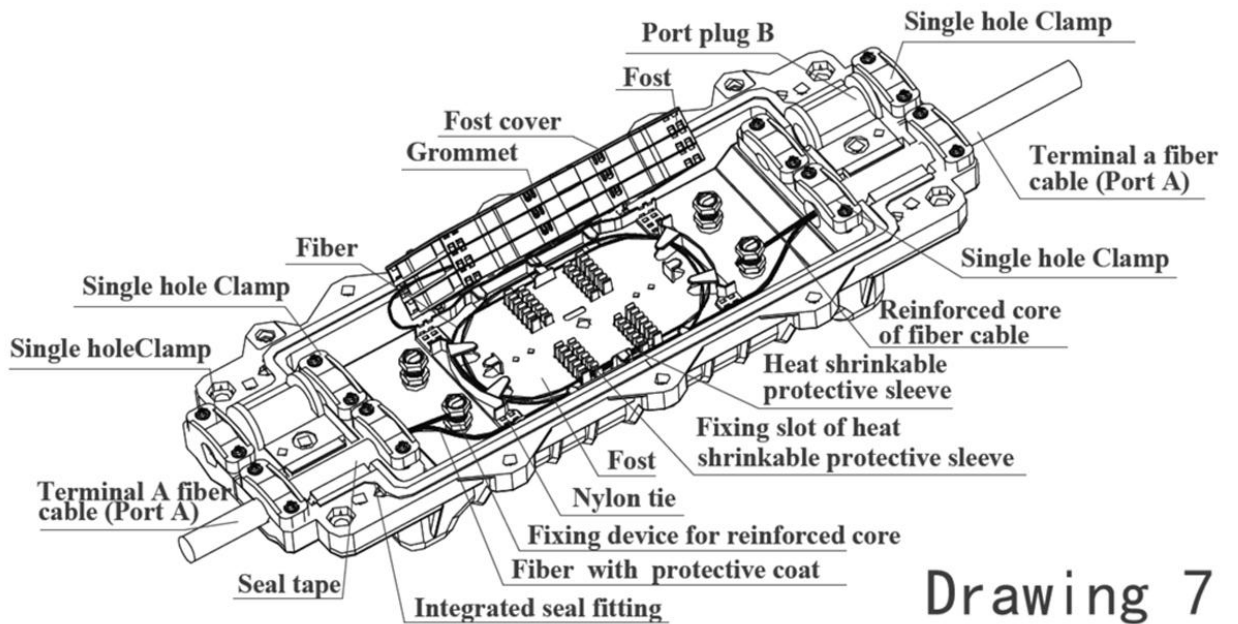

Drawing 7

Horizontal Splice Closure – 144-288 Fibre (IP68-Rated)

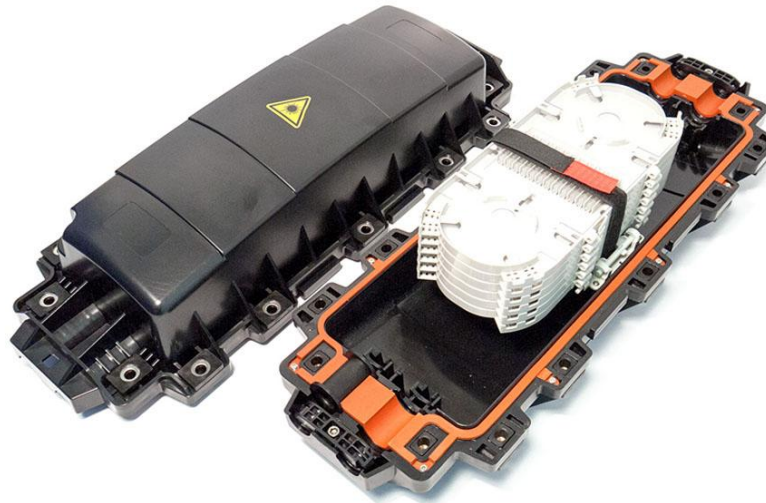

STRUCTURE DIAGRAM & DESCRIPTION

Our horizontal splice closure is designed for straight through line/branching applications, ensuring protection from the environment and is suitable for underground deployment.

FEATURES

- Material: PC
- 2 inlet, 2 outlet splice closure
- Fire resistant, waterproof, and quake-proof
- Max. capability: 288 fiber
- Environment temperature: -40°C to +75°C
- Atmospheric pressure: 70~106Kpa
- Tested and inspected to the highest standards
- Dimensions inc. lid (LxWxH): 605mm x 215mm x 175mm

SPECIFICATIONS

Size	≤0.3dB
Weight per unit	4.7 kg
Inlet/outlet ports	4 total (2 per side)
Diameter of fiber cable	Φ8—Φ23 (mm)
Max. Closure Capacity	Bunched: 48—288 (Cores)
	Ribbon: max.1152 (Cores)
Material	PC

Inline Horizontal Integrated Fibre Closure



STRUCTURE DIAGRAM & DESCRIPTION

This integrated fiber enclosure is made of very strong engineered plastic, with good anti-UV and anti-corrosive properties. It is water- and dust-proof, has a streamlined internal structure, good cable management and is simple to re-open. Lightweight, but extremely robust, it offers good mechanical strength & lightning protection. All metal components are stainless steel.

FEATURES

- Suitable for 2.0mm pigtails, fibre cable dia. $\leq 12.5\text{mm}$ and 16pcs drop cable in aerial, pole-mounting & outdoor wall-mounting applications
- Size: 350x190x100mm (LxWxH)
- Max. capacity: 24F (Single fibre, one tray)
- Adapters: up to 16 pieces of SC/UPC or SC/APC adapters
- Available splitter: max. 1:16 SC Micro PLC Splitter (2 installation grooves for splitter)
- Closure locks with rugged plastic clips; easy to both install and re-open
- Features separate distribution and customer compartments
- Silicon rubber sealing
- Body material: High quality PP with 25 year life span

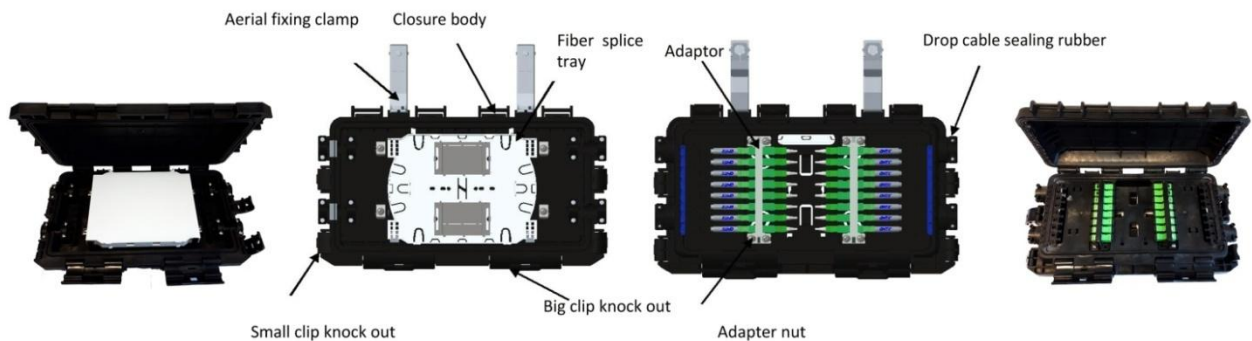

TECHNICAL PARAMETERS

- Fiber Bending Radius: $\geq 37.5\text{mm}$
- Return Loss: $\leq 0.01\text{dB}$
- Fiber length in the Tray: $\geq 1.6\text{m}$
- Working Temperature: -40°C to $+70^{\circ}\text{C}$
- Lateral pressure resistance: $\geq 2000\text{N}/10\text{cm}$
- Impact resistance: $\geq 20\text{N.m}$
- IP rating: IP68

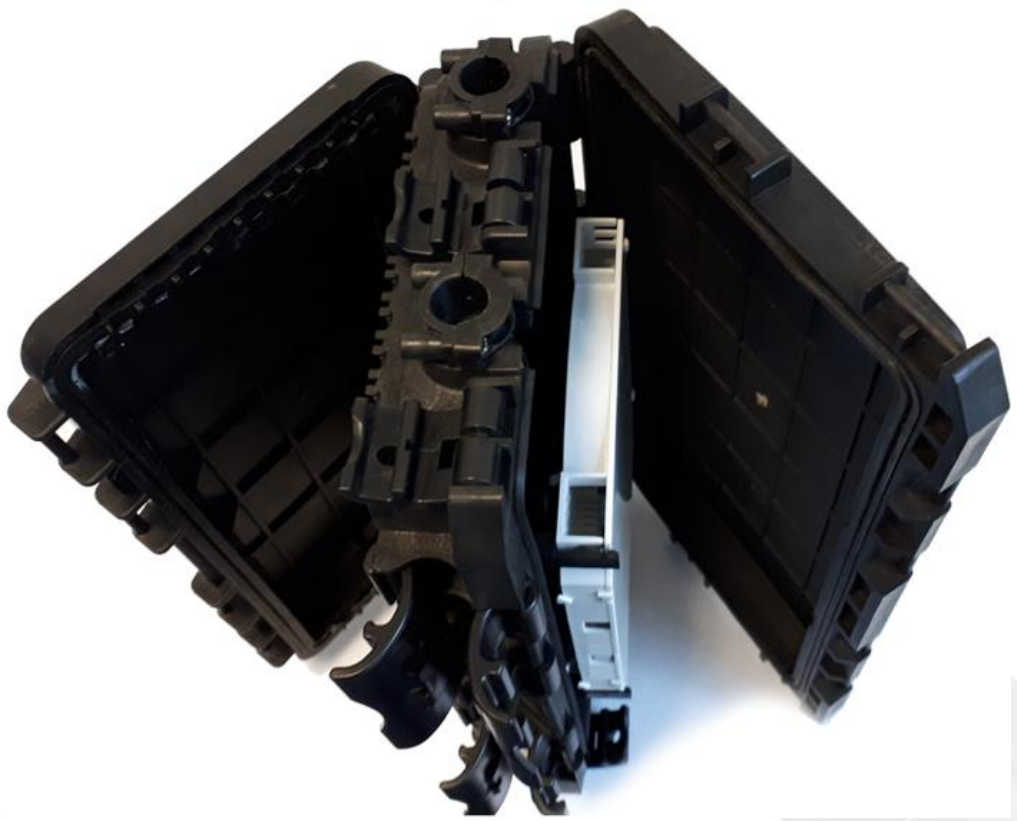

Inline Horizontal Splice Closure (IP68-Rated)

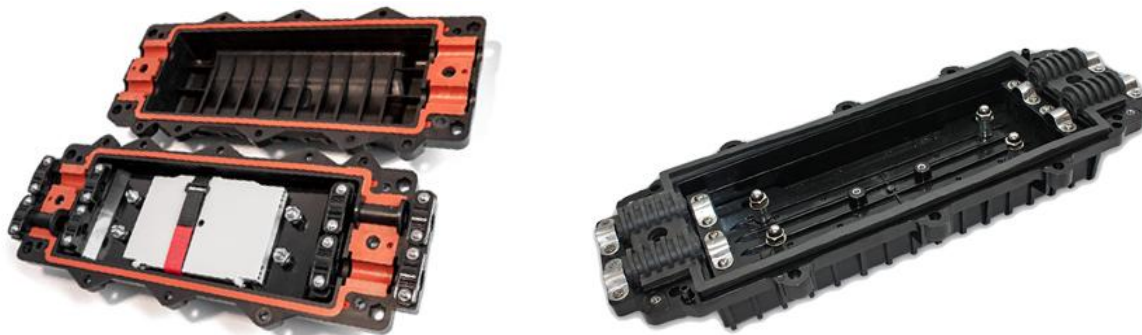

STRUCTURE DIAGRAM & DESCRIPTION

Our horizontal splice closure is designed for straight-through line/branching applications, ensuring protection from the environment and is suitable for underground deployment.

Ideal for aerial, underground, wall mounting, duct mounting and manhole mounting.

FEATURES

- Material: PP
- 2 inlet, 2 outlet splice closure
- Fire resistant, waterproof, and quake-proof
- Cable entry & exit: 2-entry, 2-exit
- Tested and inspected to the highest standards
- Dimensions inc. lid (LxWxH): 460mm x 190mm x 120mm

SPECIFICATIONS

PARAMETERS	CHARACTERISTICS
Operating Temperature	-40°C to +65°C
Weight per unit	2.95kg
Inlet/outlet ports	4 total (2 per side)
Diameter of fiber cable	Φ5—Φ20 (mm)
Max. Closure Capacity	Bunched: 12-96 (Cores)
	Ribbon: max.144 (Cores)
Material	PP



Drawing

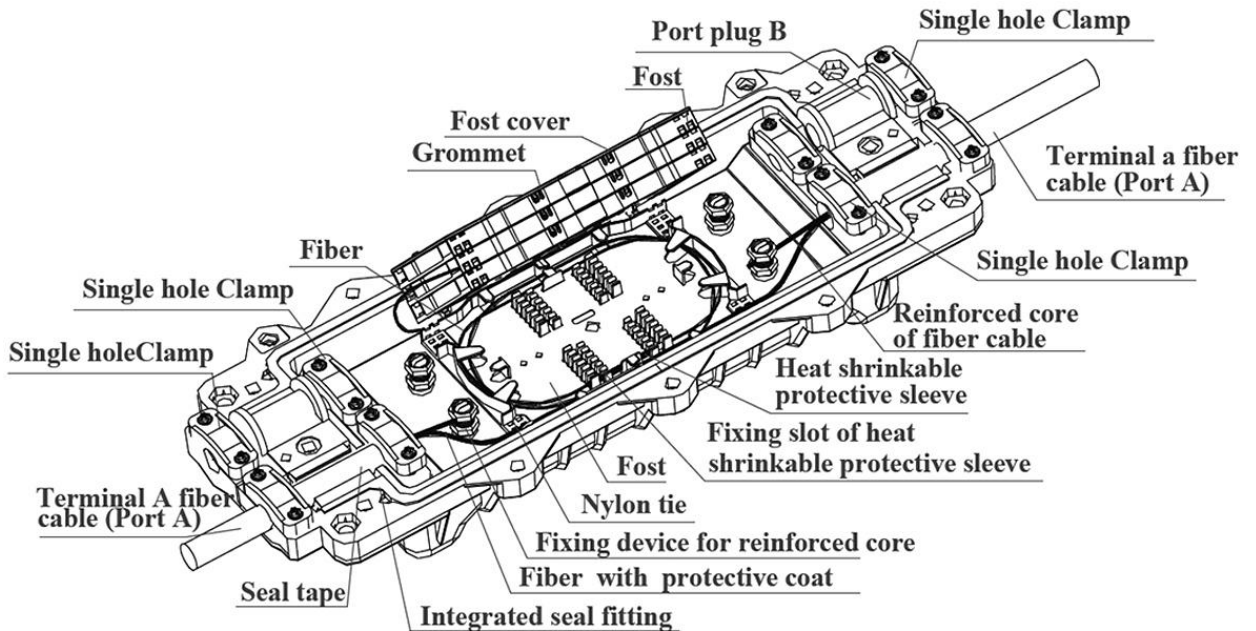
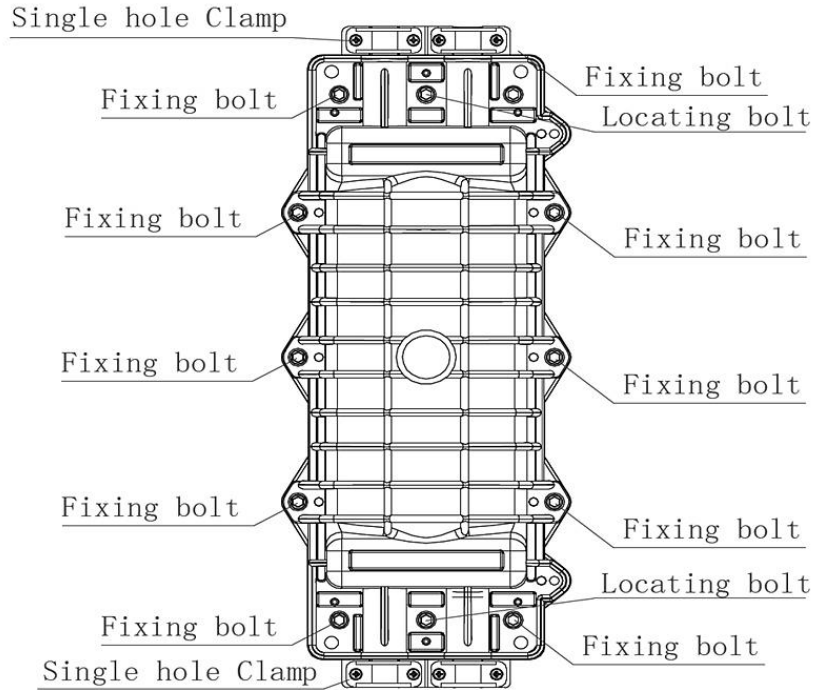

96 Fibre Inline Horizontal Splice Closure (IP68-Rated)



STRUCTURE DIAGRAM & DESCRIPTION

Our new 96 fibre closure is constructed using high strength engineered (PP) plastic, with Anti-aging, anti-UV & anti-corrosive properties. The closure is waterproof with anti-particle ingress properties, providing a compartmental design structure with easy fibre access, installation and uncomplicated latching for closing and re-opening. The closure has easy access for secondary cable splicing / FTTH project management.

FEATURES

- Dimensions: 350mm x 190mm x 100 (L x W x H)
- Suitable for 2.0mm pigtailed and 16 pieces of drop cable (cable diameter $\leq 12.5\text{mm}$) for aerial, pole-mounting & wall-mounting applications
- Maximum 4 x 24 fiber splice trays (each tray 2 x 6 double-sided = 24)
- Maximum Capacity 96 fiber (splicing only)
- Adapter capacity: 24 x SC/UPC or SC/APC Simplex
- Accommodates 2 x PLC splitters (2 x installation grooves for splitter)
- 4 entry port end caps and 12~24 fiber cable sealing silicone rubber compound strips
- Bolt-free closure, sealed with locking clamps; sealing material made of flexible silicon rubber
- Dual opening enables fiber segregation, splicing on one side and an adapter compartment on the other side

SPECIFICATIONS

Fiber bend radius	$\geq 37.5\text{mm}$
Adapter return loss	$\leq 0.02\text{dB}$
Length of fiber in the tray	$\geq 1.6\text{m}$
Operating temperature	$-40^{\circ}\text{C} \sim +70^{\circ}\text{C}$
Lateral pressure resistance	$\geq 2000\text{N}/10\text{cm}$
Impact resistance	$\geq 20\text{N.m}$



Fibre Optic Combination Splice Closure



STRUCTURE DIAGRAM & DESCRIPTION

The combination splice closure is a single ended, environmentally sealed enclosure for fibre management, primarily for outside plant networks. The closure can be deployed in aerial, pole-mount and underground environments.

TECHNICAL PARAMETERS

- Working temperature: -40°C to +65°C
- Atmospheric pressure: 70-106Kpa
- Axial tension: > 1000N/1min
- Tensile resistance: 2000N/ 10 square centimeter (1 min)
- Insulation resistance: > 2*104MΩ
- Voltage safety factor: 15KV(DC)/1 min, no arc-over or breakdown
- Temperature cycle: -40°C to +70°C, Inner pressure @ 60(+5)kPa
- Over 10 cycles, decreases in pressure and does not exceed 5kPa at room temperature
- 25 years life span
- IP67-rated



SPECIFICATIONS

Model	OPT-AD-SPLICE-144F		
Material	PP alloy		
Material – Tray	ABS		
Dimensions	278*163*451mm (LxWxH)		
Max capacity	144F	96F (Tray for this model can also hold 1:4 splitters)	96F -remove the 4
Maximum fibre capacity	12-Fibres per tray, each section holds 4 trays	8-Fibres per tray, each section holds 4 trays	4-Fibres per tray, each section holds 8 trays
Cable dia. for 6 round ports	Φ6mm~Φ33mm		
1 large round port	Φ10mm~Φ25mm		
Cable sealing	heat shrinkable sealing		
Storage	Additional back place for excess fibre storage		

Fibre Optic Splice Multiport Closure (Max-288 Fibres)



STRUCTURE DIAGRAM & DESCRIPTION

Our Multiport Closure is designed with a resealable structure. Made of injection-molded engineered plastic with excellent mechanical strength and anti-aging properties. It is flame retardant, waterproof, vibration and impact resistant. It has a reliable sealing performance. Each tray can hold 24x (12F) trays, max 288F, with one oval port and 16 round ports.

FEATURES

- Easy fibre management
- Constructed using high strength engineered plastic, with Anti-aging, anti-UV & anti-corrosive properties.
- Base-to-dome seals on FOSC are mechanical and heat-shrinkable for ease of installation and reentry. No other sealing adhesive tape is needed
- Base and dome sealed with clamp and O-ring system
- The splice trays are hinged for access to any splice without disturbing others trays
- The inner parts and fixing parts are made of stainless steel
- FOSC with a earthing device protect it from damage by lightning
- Compatible with most cable types (single fiber or ribbon), and cable constructions(loose tube, central core, slotted core, modular). And the product can be used in any environment (aerial, buried, handhole, manhole) and in many applications (tap-off, expressed, branch, and repair)
- No special tools are needed to open the closure, and it can be opened and used repeatedly

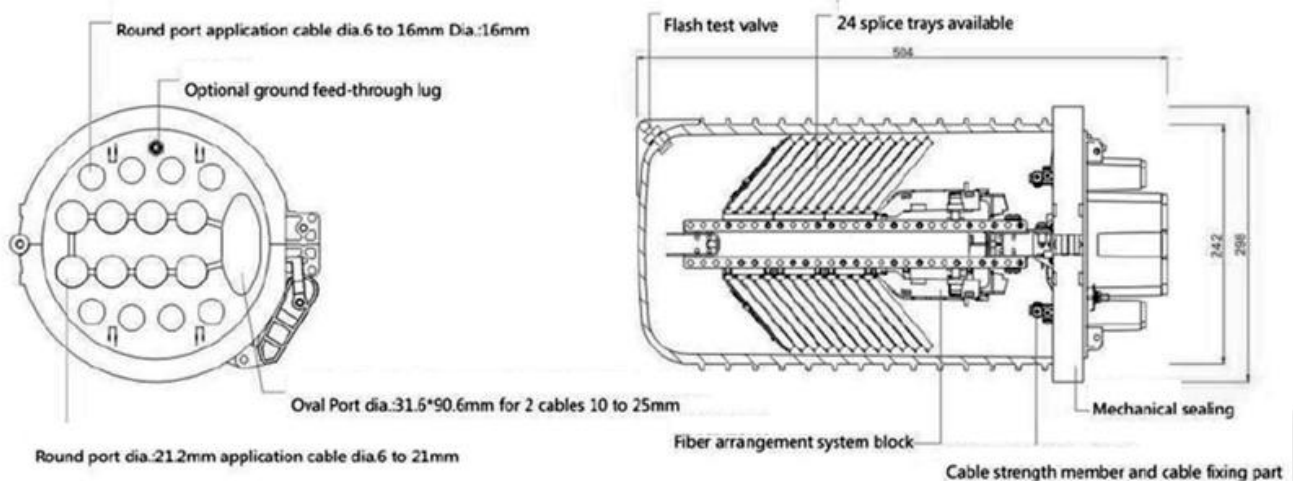

SPECIFICATIONS

Material	PP alloy
Tray material	ABS
Size	504*dia 298mm
Max capacity	288F
Tray capacity	12F
8 large round ports	with dia. $\Phi 6 \sim 21\text{mm}$
8 small round ports	with dia. $\Phi 6 \sim 16\text{mm}$
1 oval port	with size $\Phi 10\text{mm} \sim \Phi 25\text{mm}$

APPLICATION

- Ideal for aerial, duct, direct burial and manhole applications.

TECHNICAL PARAMETER

- Working temperature: $-40^{\circ}\text{C} \sim +70^{\circ}\text{C}$
- Atmospheric pressure: $70 \sim 150\text{Kpa}$
- Axial tension: $>2000\text{N}/1\text{min}$
- Stretching resistance: $2500\text{N}/10$ square centimetre(1min)
- Insulation resistance: $>2 * 10^4\text{M}\Omega$
- Voltage strength: $15\text{KV}/1\text{min}$, no arc over or breakdown
- Pressure in the water: $50\text{m}/72\text{hours}$
- Splice tray with optical take up radius $\geq 40\text{mm}$ low optical loss



Snap Lock Combi Closure



STRUCTURE DIAGRAM & DESCRIPTION

The Snap Lock Combi Closure is an enclosure with key design features, ease of operation and a high degree of ingress protection.

There is one uncut cable port (for cable diameter D10~D17.5mm), 16 small cable ports (cable diameter less than 4mm) and 2 branching cable ports (cable diameter D8~D17.5mm by changing sealing units).

The unit allows for a maximum of 96 fibres (4x 24 fibre splice trays). Additionally, either a 1:16 splitter or 2x 1:8 splitters can be installed on the splice trays. This enclosure can also accommodate a SC adapter plate for drop cable applications.



FEATURES

- Box Material: Modified polymer plastic
- Seal Material: Vulcanised silicone rubber
- Physical size (mm): 380×245×130
- Weight (kg): 3~3.5
- Mechanical seal: IP68-rated
- Installation: wall mounting, pole mounting and direct burial

Compact Fibre Joint Closure (IP68-Rated)



STRUCTURE DIAGRAM & DESCRIPTION

This is our latest product to complement the standard range of optical closures, but features a more compact design. It is ideally suited for wall-mounting, yet remains resistant to acid and alkaline, also common to the larger closures. Its' airtight and waterproof construction makes it ideal for applications in tight or restricted areas.

FEATURES

- 2 inlet, 2 outlet splice closure
- Splice trays available
- Maximum capacity 48 fibres (4 x 12 way trays)
- Tested and inspected to the highest standards



Slim Line Fibre Closure (IP68-rated)



STRUCTURE DIAGRAM & DESCRIPTION

The slim line fibre closure is compatible with most cable constructions and allows easy and convenient re-entry and re-closure. It features a splice tray with an optical fibre radius of $\geq 40\text{mm}$ and results in very low optical loss.

The outer metal components and fixing units are made of stainless steel, so it can be repeatedly used in different environments.

FEATURES

- Maximum capacity: 24 F
- Body material: PP
- Outer material: 304 stainless steel
- Applicable cable dia.: 3mm~10.8mm
- Four cable ports: two inlet and two outlet
- Dimensions (L×W×H): 249mm × 153mm × 30mm

IP68 Splice Closure 3 Port

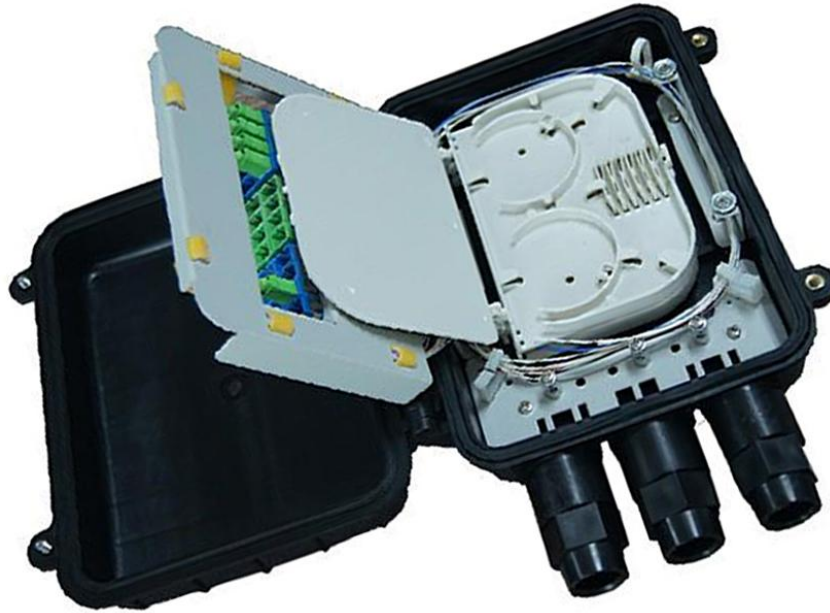

STRUCTURE DIAGRAM & DESCRIPTION

Our new 3 port IP68 splice closure provides 3 fibres cable input / output round ports. It is made from high-quality ABS plastic with an extremely robust mechanical sealing system.

APPLICATIONS

- For aerial hanging or wall-mounting
- Suitable for PLC splitters, 1x2~1x16
- Accepts SC, FC & LC adaptors

SPECIFICATIONS

Dimensions (H x W x D)	cm	28.5 x 20 x 9
Weight	kg	1.4
Cable diameter in/output	mm	8-14
Cable entry ports	-	1 in & 2 out
Max. capacity	-	24 fibres

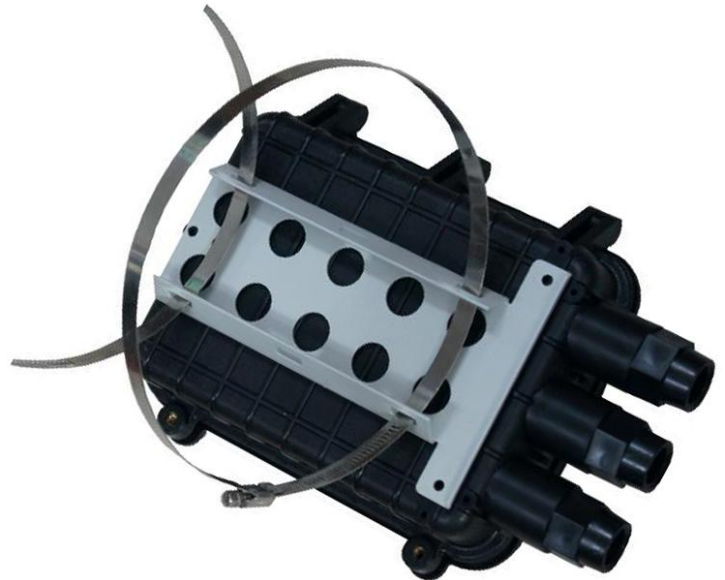

96 Fibre Lockable Termination Enclosure (IP65 Rated)



STRUCTURE DIAGRAM & DESCRIPTION

The 96 fibre lockable termination enclosure is suitable for various fibre-related applications / installation programs for combined splicing and/or direct connection to SC Simplex / LC Duplex adapters. The enclosure can be used internally and externally.

FEATURES

- Dimensions: 49 x 39 x 14.5cm
- Weight: 9.1kg
- Material: SMC
- Environmental temperature: -40°C ~ 85°C
- Maximum capacity: 96 fibres
- Different adapter types can be installed

APPLICATIONS

- Telecommunications subscriber loop
- Fibre to the home (FTTH)
- LAN/WAN
- CATV

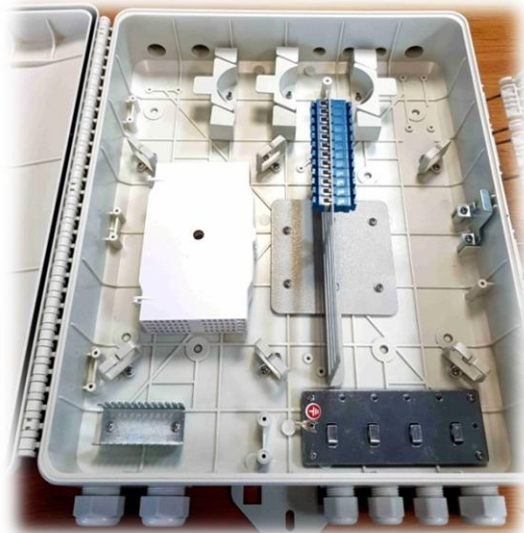

24-Way Small Lockable Wall Box (IP65-rated)



STRUCTURE DIAGRAM & DESCRIPTION

The 24-way small lockable ABS wall box offers the ability to terminate 24 fibers in a IP65-rated housing. It is suitable for both 6 x SC Duplex and 6 x LC QUAD adapters and can be used internally and externally. Offers up to 12 exit points for patching cables and 1 standard cable entry point for loose tube, tight buffered, pre-terminated and steel tape armoured cable. Each enclosure has integrated strength member tie positions and bend radius protection with the addition of a removable front door, allowing for quick and easy installation.

FEATURES

- Up to 24 fibre
- Removable splice tray for easy installation
- Multiple adapter options available
- 6 adapter positions
- IP65-rated
- Integrated bend radius protection
- Sealing glands for up to 24 exiting cables + 1 incoming cable
- Lockable door
- ROHS, REACH & SvHC compliant
- Supplied with 24 heatshrink splice protectors, transit tubing, wall fixings and tie wraps

SPECIFICATIONS

PARAMETERS	UNIT	CHARACTERISTICS
Dimensions (HxWxD)	mm	258x186x61
Weight	g	850
Cable entry/exit	mm	20
Operating temperature	°C	-40 ~ +60
No. of fibers	-	Up to 24
Adapter options	-	LC Quad and SC Duplex
Material	-	ABS

12 Fibre Plastic Wall Box (IP65-Rated)



STRUCTURE DIAGRAM & DESCRIPTION

This terminal box terminates up to 12 fibers. It is a perfect cost-effective solution for FTTx networks.

TECHNICAL SPECIFICATION

- ABS with PC material construction ensures a strong, yet lightweight housing
- Water-proof design for outdoor use
- Easy installation: ready for wall-mounting installation kits provided
- Adapter slots used - no screws or tools needed for installing adapters
- Ready for splitters; designed with space for adding splitters
- Cable fixing units providing for fixing outdoor optical cable
- IP65 protection level
- Accommodates both cable glands and tie-wraps
- Lock provided for extra security
- Dimensions: 225mm x 200mm x 65mm (including lid)

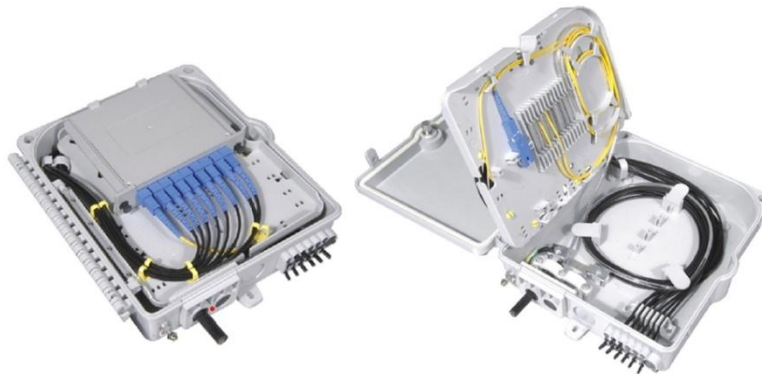

24 Fibre Plastic Wall Box (IP65-rated)



STRUCTURE DIAGRAM & DESCRIPTION

This terminal box terminates up to 24 fibres. It is a perfect cost-effective solution for FTTx networks.

Dimensions (including lid): 320mm x 240mm x 100mm

FEATURES

- Made of strong and lightweight ABS material
- Water-proof design for outdoor use
- Easy installation & ready for wall mounting – installation kits included
- Adapter slots used – No screws or tools needed for installing adapters
- Ready for splitters: designed with space for adding splitters
- Cable fixing units provided for fixing outdoor optical cable
- Protection Level: IP65
- Accommodates both cable glands and tie-wraps
- Lock provided for extra security



Snap-Lock Wallbox (IP65-Rated)



STRUCTURE DIAGRAM & DESCRIPTION

The Snap Lock IP65 distribution box offers the ability to terminate 16 fibers in a strong yet lightweight ABS housing. Suitable for both SC Simplex and LC Duplex adapters. Can be used internally and externally. Offers up to 24 exit points for patching cables and 1 standard cable entry point for loose tube, tight buffer, pre-terminated and steel tape armoured cable. Each enclosure has integrated strength member tie positions and bend radius protection with the addition of a removable front door allowing for quick and easy installation.

FEATURES

- Up to 16 fibres
- Snap-lock doors
- Removable splice tray for easy installation
- Multiple adapter options available
- 16 adaptor positions
- IP 65
- Integrated bend radius protection
- Sealing glands for up to 24 exiting cables + 1 incoming cable
- Lockable door
- ROHS, REACH & SvHC compliant
- Supplied with 24 heatshrink splice protectors, transit tubing, wall fixings and tie wraps

SPECIFICATIONS

Dimensions (H x W x D)	mm	306 × 140 × 106
Weight	G	850
Cable entry/exit	mm	20
Operating temperature	°C	-40 ~ +60
Max adapters	-	Up to 16
Adapter type	-	SC Simplex / LC Duplex
Material	-	ABS



Splitter Terminal Wallbox (IP65-Rated)



STRUCTURE DIAGRAM & DESCRIPTION

The IP65-rated splitter terminal box is a rugged, low cost and low profile wall box for use between central office and multi-dwelling units of FTTH networks. It features a multi-layer internal design, which allows access to necessary components for installers and subscribers. It can house splitters and allows for pigtail splicing of distribution/drop cables as needed.

FEATURES

- Indoor and outdoor rated
- Available as 1x4, 1x8, 1x16, 1x32, 2x4, 2x8, 2x16 splitter variations
- Maximum of 32x FTTH drop cable or pigtails
- Suitable for wall- or pole- mounting
- 2 Inlet ports; 36 outlet ports

APPLICATIONS

- FTTH, GTTB, FTTC
- Telecommunication Networks
- CATV
- Local Area Networks (LAN)

SPECIFICATIONS

Dimensions (H x W x D)	mm	380 x 290 x 115
Weight	kg	2.6
Cable entry/exit	mm	20
Operating temperature	°C	-40 ~ +60
Max adapters	-	36
Adapter type	-	SC Simplex / LC Duplex
Material	-	ABS



Extra-Large Lockable Wallbox (IP65-Rated)



STRUCTURE DIAGRAM & DESCRIPTION

The 48 fibre IP65 IP65-rated is used for the distribution and termination of fibre optic cable devices. The IP-rated box can be utilised for FTTH applications and other installation requirements to break-out and splice input cables into drop cables, pigtails, or direct patching. The box may also be used for protective interconnection of a fibre network and is suitable for outdoor, riser and tunnel installations up to 48 fibres.

FEATURES

- The box is made of anti-ageing materials with ultraviolet protective characteristics
- The sealing mechanism is based on pressed rubber/silicon strips and is rated to IP65
- The box is fitted with a lock for additional security and can be wall- or pole- mounted
- Operating temperature: -20°C ~ +70°C; storage: -40°C ~ +80°C
- Spare loops of pigtails and drop cables can be stowed in the storage compartment for convenience or for maintenance
- Special locking device for output cables
- Bi-layer structure for splicing and upper layer for splitting and distribution
- Up to 48x adapter ports (FC/ST and SC Simplex/LC Duplex)

SPECIFICATIONS

Dimensions (H x W x D)	mm	320 × 350 × 120
Weight	kg	2.6
Cable entry/exit	mm	20
Operating temperature	°C	-40 ~ +60
Max adapters		36 to 48
Adapter type		SC Simplex / LC Duplex
Material		ABS





FIBRE MAINTAINANCE

1u Cable Bar with Brush-Strip

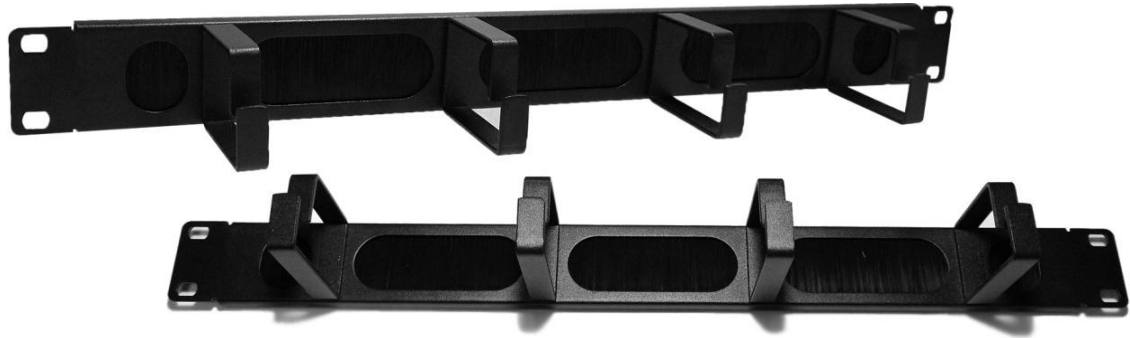

STRUCTURE DIAGRAM & DESCRIPTION

Extensive fiber networks contribute not only to supporting connectivity for homes and businesses (FTTx), but are also necessary to enable deployment of 5G mobile networks, the Internet of Things (IoT) and digital services and applications which rely on high bandwidths and low latency.

FEATURES

- 1U Height
- 19" Rack Mountable
- Integrated brush strip
- Will fit any 19" rack
- Ability to pass patch cords to the rear of cabinets without affecting airflow

APPLICATIONS

- Data centres, premise installations, telecommunication networks
- Ethernet, Fibre Channel, ATM, LAN, MAN and WAN
- Data communication
- Indoor applications

SPECIFICATIONS

ELEMENTS	CHARACTERISTICS
Height (mm)	44
Width (mm)	8
Depth (mm)	90
Net weight (kg)	0.33
Number of cable rings 65mm	4
Material	Cold rolled steel
Material thickness (mm)	1.2
Colour	Black RAL 9004
Operating temperature (°C)	-40 to +60
Designed in accordance with	TIA/EIA 568.C, ISO/IEC 11801, EN50173, IEC60304, IEC61754
Compliant with	RoHS, Reach/SVHC

144 Fibre Cable Breakout Unit



STRUCTURE DIAGRAM & DESCRIPTION

Ideal for managing and distributing fiber backbone cables, accommodating up to 12 tubes (each tube containing 12 fibres). Particularly suitable for ODFs/racks & cabinets/enclosures, where trunk or backhaul network cable requires distributing into separator ports or locations. Miniflex 5mm cable protection tubes* are used at distribution points, where multi-fibre cables need to have the vulnerable individual fibres or cable elements separated & protected by a management system. *Miniflex 5mm protection tubes sold separately. The unit is supplied with a cover (gland box) for further protection and for mechanically anchoring the gland. Used in splice joint housings, racks and other fibre network infrastructures for cable breakout & retention and subsequent protected circuit routing in Miniflex protection tubes or used in conjunction with the gland box for a standalone solution.

DIMENSIONS

- Overall length including gland = 155mm
- Width = 50mm
- Height = 30mm



Connector Cleaner Cassette



STRUCTURE DIAGRAM & DESCRIPTION

Our fibre optic connector cleaner utilises a specially formulated dry cloth for thorough and efficient cleaning of fibre optic end-faces. It eliminates the need for hazardous cleaning fluids, which can leave a residue. The cloth is extremely effective in removing grease, dust and other contaminants.

FEATURES

- Suitable for cleaning tasks in factories and field applications
- Environmentally friendly
- Achieves high quality cleaning without alcohol or other solvents
- Replaceable cleaning cassette
- An ideal tool for cleaning connector faces
- Specifically designed to clean ST, SC, FC, SMA D-4, DIN and diamond connector faces

SPECIFICATIONS

- Connectors cleaned: SC, FC, ST, DIN, MU, LC, MTP/MPO and MTRJ (without pins)
- Dimensions: W x H x D 130mm x 75mm x 40mm
- Weight : 200g

FERRULE

- $\phi 2.5\text{mm}$ $\phi 1.25\text{mm}$



One-Click Cleaner & Connector Cleaning Card



Cleaning Swabs:
1.25mm and 2.5mm

FUJIKURA ONE-CLICK™ CLEANER

The FUJIKURA One-Click Cleaner cleans adapter-mounted SC, ST & FC or LC & MU connectors with a simple single-action (push/release) cleaning system. It's effective with a variety of contaminants and with over 500 cleaning cycles per unit, it also has a remarkably low cost per clean. An adapter/dust cap is supplied for cleaning either SC, ST & FC or LC & MU. Compliant with the EU/95/2002/EC Directive (RoHS).

FEATURES

- Cleans adapter-mounted SC, ST, FC, LC & MU connectors
- Single-action cleaning system
- Effective with a variety of contaminants
- Over 500 cleans per unit
- Adapter dust cap supplied
- Compliant with EU/95/2002/EC Directive (RoHS)
- Covered by US Patent No. 8,087,118



Also Available:

Economy Cleaning Card: Made from disposable card. Designed for simplex connectors featuring 12 single-use cleaning windows. Just run the ferrule across the window in a 'Z' shape motion for effective cleaning.

CONNECTOR CLEANING CARD

Designed to replace hazardous solvents, this product easily and effectively removes interstitial and loose tube (thixotropic) filling & flooding compounds without damage to cable or fiber optic components (inks & delicate coating materials). This product has no skin or inhalation risk.

FEATURES

- High cleaning capability
- Convenient storage
- Dry cleaning
- Over 500 cleans per unit
- Cleaning surfaces are individually sealed
- Dust-free and covered with a lid when not in use

Pre-Saturated (IPA) Wipes



These are pre-saturated wipes for general cleaning applications. These are tough non-woven engineering wipes impregnated with quick evaporating IPA (Isopropyl Alcohol) for the removal of grease, grime and marking inks from all surfaces.

Also Available:

Lint free wipes for the cleaning of optical fibres and connectors, available in different quantities and sizes.

Field Installable Connector Kit



FEATURES

- Toolkit contains all relevant tools to terminate our FIC connectors
- Excellent kit for standard fibre termination
- Lightweight and easy to carry/transport

CONTENTS

Compact fiber cleaver	x 1
FIC connectors	x 20
Carrying case 300 x 300 x 120mm	x 1
Pen style cleaving tool	x 1
IPA wipes	x 10
Lint free wipes	x 100
Kevlar scissors	x 1
Tri hole stripping tool	x 1
Optional extras - 2.5mm VFL and 1.25mm VFL	



Mechanical Fibre Splice



STRUCTURE DIAGRAM & DESCRIPTION

Our mechanical fibre splice utilises V-Groove butting technology, which has been designed to optimise insertion loss for singlemode and multimode applications. Its' design facilitates rapid assembly, with only minimal tooling required.

FEATURES

- Transparent body for immediate connecting confirmation
- Co-axial self-centering guides provide excellent & durable continuous enhanced optical performance
- No tools required
- No epoxy required
- Fully compatible for use with 250 μm and buffered fibres
- Easy assembly with a high yield success rate can be achieved in as little as 30 seconds

APPLICATIONS

The mechanical splice is widely used and suitable for multiple applications, such as in distribution units, multimedia boxes, patch panels, drop cable with pigtails or repairing any damaged fibre lines.

SPECIFICATIONS

Fiber size	μm	250 and 900
Mean insertion loss	dB	0.1
Typical return loss	dB	-50
Typical pull strength	N	5
Operating temperature	$^{\circ}\text{C}$	-45 ~ +85
Materials	-	Engineered plastics and index matching gel
Dimensions (L x H x W)	Mm	38 x 3.8 x 6.5



Fibre Management Accessories



12 / 24 way Splice Bridges

Two-piece black plastic splice bridge, suitable for 12 or 24 (piggy-backed) fusion splices. It has a non-adhesive backing, which can be fixed to the panel by a single screw/bolt in the middle of the moulding base.



Cable Glands and Bunny Clips

Cable glands to accept most fiber cables up to 24 core. Twisting bunny clips featuring a self-adhesive pad for fiber organization.



Splice Protectors

Fiber splice protectors available in 45mm or 60mm. Clear plastic tube with steel insert for rigidity.

Fibre Management Splice Trays



STRUCTURE DIAGRAM & DESCRIPTION

Fibre management splice trays act as a means of organizing fibre splices within fibre management products such as patch panels and closures. Available in different configurations, colours and sizes, they are secured either with bolts to the fibre panel or with the use of self-adhesive pads (not supplied). Available as 45mm or 60mm versions.

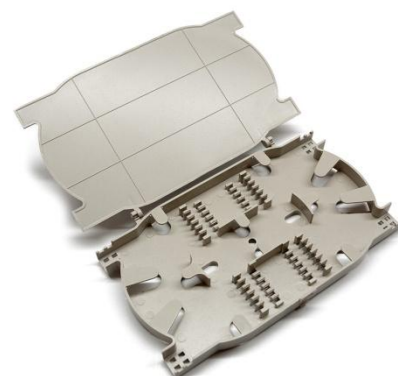



FTTH

Pre-Terminated 4-Port FTTH Wall Box

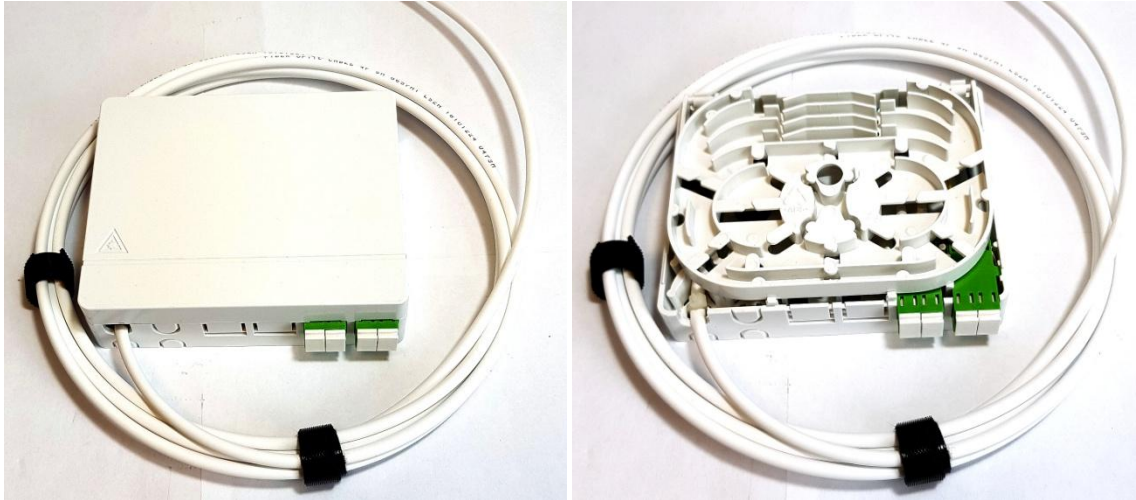

FEATURES

- Wall-mountable
- Clip-on, clip-off lid
- Separate hinge section for splicing & fibre management
- Suitable for SC Simplex & LC Duplex adapters or adapters with a SC Simplex footprint
- Multiple cable entry points for 3mm to 5mm cables
- Terminated from one to four fibres

STRUCTURE DIAGRAM & DESCRIPTION

4-Fibre FTTH Box is constructed from lightweight but strong ABS material. It features a compact design with a clip-on, clip-off lid for ease of access during installation, incorporating a hinged splice tray. The box can be terminated up to 4 fibres, with cable lengths to suit, with or without card reel.

Dimensions Length = 100mm, Width = 80mm, Height = 30mm

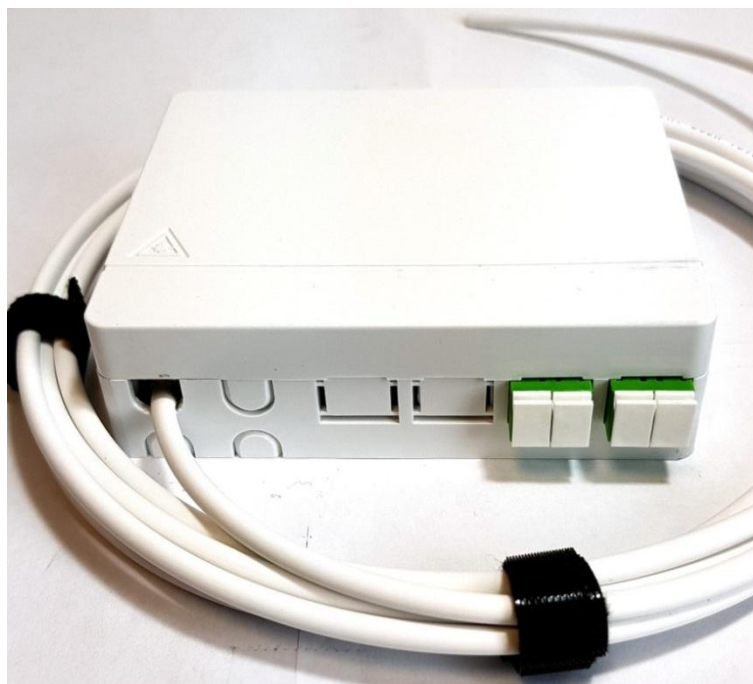

IP65 2 Way Small Central Lock Wall Box



STRUCTURE DIAGRAM & DESCRIPTION

The IP65 2-way central lock wall box is used for the distribution and termination of fibre optic cable devices. The IP rated box can be utilised for FTTH applications and other installation requirements to break-out and splice input cables into drop cables, pigtails, or direct patching. The box may also be used for protective interconnection of a fibre network and is suitable for outdoor, riser and tunnel installations.

FEATURES

- The box is made from anti-ageing materials with ultraviolet protection
- The sealing mechanism is based on pressed rubber/ silicon strips and is IP65-rated
- The box is fitted with a lock for additional security and can be wall- or pole- mounted
- Operating temperature: -20°C~+70°C; storage: -40°C~+80°C
- Spare loops of pigtails and drop cables can be stowed in the storage compartment for convenience or for maintenance
- Special locking device for output cables

SPECIFICATIONS

Dimensions (including lid)	mm	150x130x37
----------------------------	----	------------

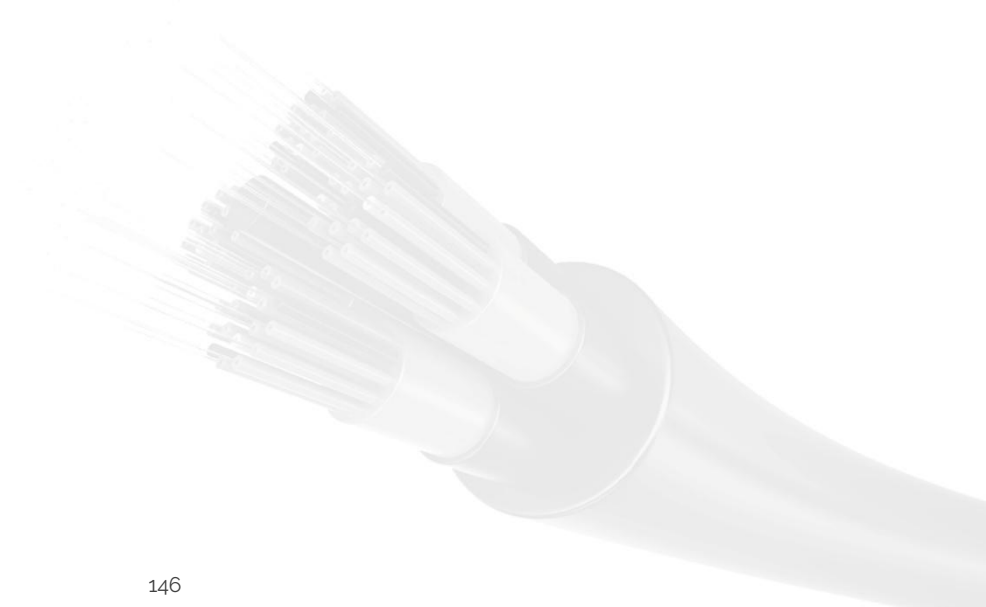

Single-Port FTTH Hinge Wall Box



STRUCTURE DIAGRAM & DESCRIPTION

ICL's Single-Port FTTH Box is constructed from lightweight, but strong ABS material. It features a compact design with a hinged lid for ease of access, incorporating an integrated splicing area. Depending on the Adapter, the Box can be terminated to 2-fibres and can be supplied, loaded, unloaded, or pre-terminated with cable length to suit.

FEATURES

- Wall mountable
- A hinged lid includes cable cut-outs allowing cable entry/exit
- Splicing & fibre management for up to two fibres
- Includes cable anchoring tags on either side of the base unit for additional cable security
- Suitable for SC & LC Adapters, or Adapters with an SC Simplex profile

Dimensions

Overall Length = 109mm, Base = 86mm x 86mm, Height = 23mm

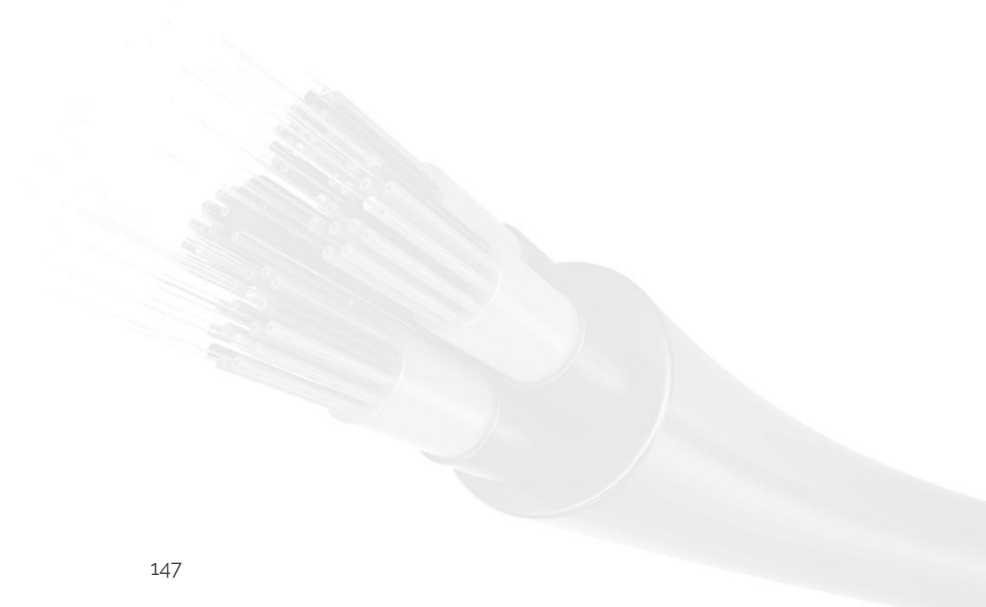

Mini Fibre Optic Splice Closure



STRUCTURE DIAGRAM & DESCRIPTION

The Mini Fibre Optic Splice Closure is an inline closure, made of high quality ABS plastic and includes a silicone sealing gasket for ingress protection.

FEATURES

- A small compact splice enclosure, designed specifically where space is a premium
- ABS plastic material, available in white or black
- 2 cable entry ports, one on either side (for cable diameters up to 8mm)
- 6 double-stacked fibre slots are provided for maximum 12 splices
- Cable strength member with anchoring screw-downs
- The enclosure can be wall mounted or for aerial/catenary hanging
- Dust-proof and water resistant to IP65

DIMENSIONAL PROPERTIES

- 190 x 90.1 x 21.5 mm

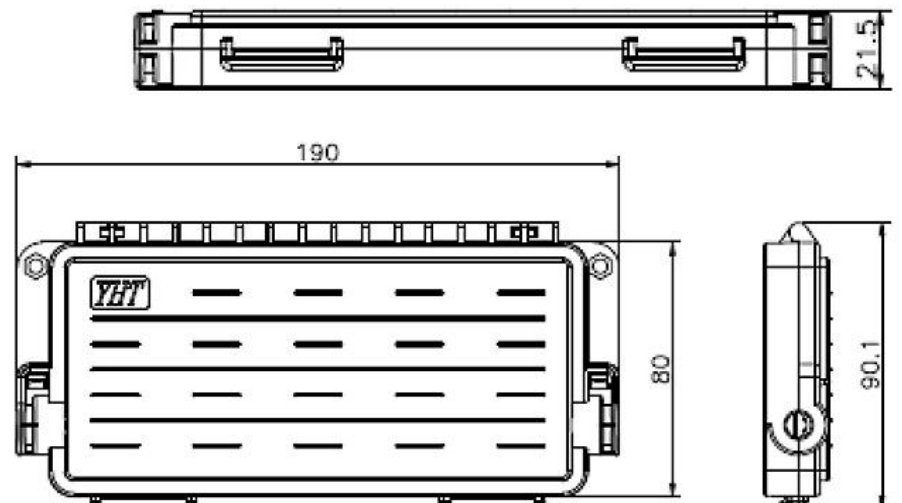

2 way Sliding Connector Cover FTTH Box



STRUCTURE DIAGRAM & DESCRIPTION

This FTTH box features a sliding section for connector protection. It is a perfect cost-effective solution for FTTx networks.

FEATURES

- Made of strong and lightweight ABS (with PC) material
- Adapters simply slot into place, no need for screws or tools
- Adaptors: SC Simplex and LC Duplex
- Temperature range: -40°C to +75°C
- Dimensions: 84mm x 130mm x 24mm

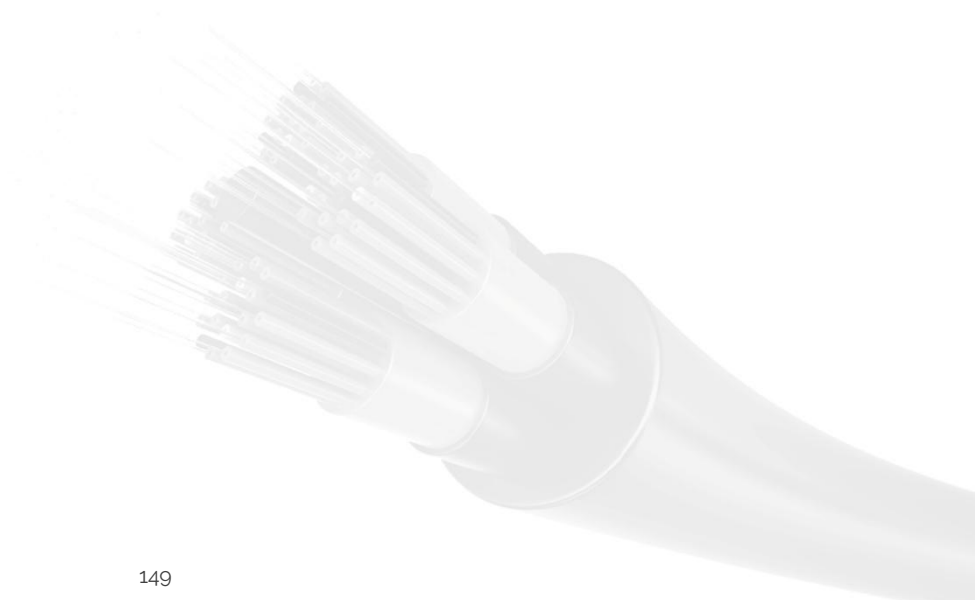

4-Way Lock & Latch Wall Box (IP65-Rated)



STRUCTURE DIAGRAM & DESCRIPTION

The IP65 4-way lock & latch wall box is used for the distribution and termination of fiber optic cable devices. The IP-rated box can be utilised for FTTH applications and other installation requirements to breakout and splice input cables into drop cables, pigtails, or direct patching. The box may also be used for Protective interconnection of a fiber network and is suitable for outdoor, riser and tunnel installations.

TECHNICAL SPECIFICATION

- The box is made of anti-ageing materials with ultraviolet protective characteristics
- The sealing mechanism is based on pressed rubber/silicon strips and is rated to IP65
- The box is fitted with a lock for additional security and can be wall- or pole- mounted
- Operating temperature: -20°C ~ +70°C; storage: -40°C ~ +80°C
- Spare loops of pigtails and drop cables can be stowed in the storage compartment for convenience or for maintenance
- Special locking device for output cables
- **Dimensions (including lid):** 191 x 120 x 44 mm



4 Fibre FTTx Box / 4 Fibre FTTx OSD-C Box



4 Fibre FTTx Box

STRUCTURE DIAGRAM & DESCRIPTION

ICL's fibre termination box is constructed from a lightweight, strong ABS housing. It features a compact design with a sliding removable lid for ease of access during installation, and it includes front and rear cable entry points for 3mm or 5mm cable.



4 Fibre FTTx OSD-C Box

STRUCTURE DIAGRAM & DESCRIPTION

The ICL's FTTx OSD-C is a newly developed Fibre to the Home terminal box, designed for a maximum of 4 fibres, with a clip-on cover for convenient access. Made from lightweight and durable materials, this compact and protective box is the perfect solution for FTTx applications.

FEATURES

- Wall-mounted and rack-mounted applications
- Sliding removable lid
- Unique clip-on cover for convenient access (for OSD-C Box)
- Suitable for SC Simplex, LC Duplex, E2000 adapters
- Tested and inspected to the highest standards

DIMENSIONS (including lid)

- Length: 124.24mm
- Width: 79.2mm
- Height: 26.1mm



8-Fibre Universal Box

Suitable for Wall, Riser, or Floor mounting



STRUCTURE DIAGRAM & DESCRIPTION

The 8-Fibre OPTI-8 Enclosure has been designed to accommodate up to 8 x exiting Patching fibres, but allows for an additional 8-fibres (2nd Splice Tray) to be directly fused out to a separate enclosure in a different floor, or an adjacent riser duct.

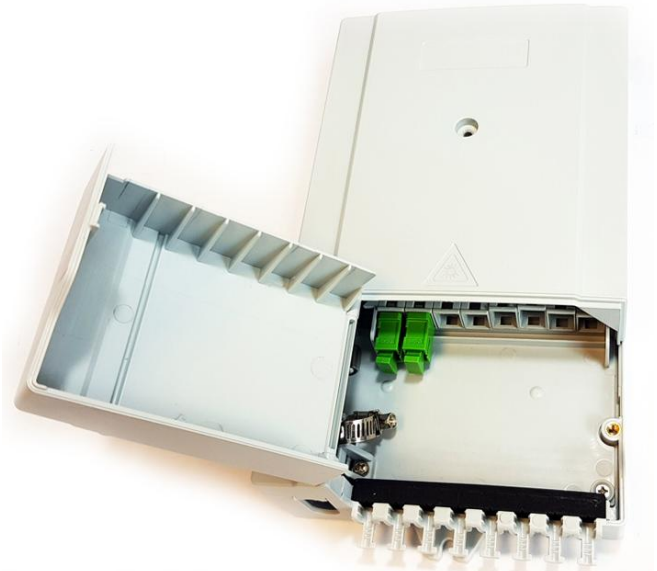
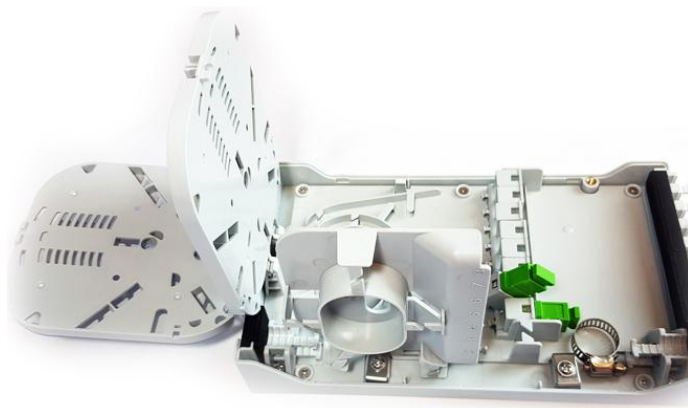

PRODUCT SPECIFICATIONS

- Function - Cable Splicing and distribution.
- Splitter Type - Accommodates bare metal type.
- Adapter Types - 8 x Ports suitable for SC Simplex footprint.
- Adapter Ports - Includes pivot anchors for ease of connect/disconnect.
- Splice Trays - 2 x Splice Trays, accommodating 8-Fibres per Tray
- Cable Entry - 2 x Main cable entry ports (top & bottom) with cable retention tags, both entry ports include rubber sealing grommets. Each of the sealing grommets can accommodate 2 x 11mm cables, alternatively cable bundles, as in the case of FTTH applications.
- Cable Entry - 2 x Main cable entry ports (top & bottom) with cable retention tags, both entry ports include rubber sealing grommets. Each of the sealing grommets can accommodate 2 x 11mm cables, alternatively cable bundles, as in the case of FTTH applications.
- Cable Exit - 8 x exit ports to accommodate, up to 5mm round/Drop cables, including a rubber sealing strip and secure cable tie-downs.
- Dimensions - Actual box length 21cms, excluding external cable tags and fixing anchors
- Overall Dimensions - L = 23.5cms x W = 12.5cms x H = 5cms
- Additional Information - The lid overall covers the base unit and fixed down with a fastener. The lid further incorporates a separate door to access external patching, leaving the Splicing area intact.

16 Fibre FTTX Outdoor Distribution Box (SC Simplex)



FEATURES

- IP65 rated and made of shatter resistant plastic
- Dust proof design, ideal for installation outdoors
- For wall-mounting or pole-mounting
- Accommodates up to 16 x SC Simplex/LC Duplex adapters
- 2 cable input ports and 8/16 output ports, suitable for 1 x 1 x 16 PLC Splitter
- Dimensions: 320mm x 260mm x 85mm

TECHNICAL PARAMETER

- Widely used in FTTH access networks
- Telecommunication Networks
- CATV Networks
- Data communication networks
- Local Area Networks
- Suitable for corridors, basements & outer walls of buildings



Customer Connection Terminal Box



STRUCTURE DIAGRAM & DESCRIPTION

Our customer connection termination box is constructed from a lightweight, strong ABS housing. It features a compact design with a hinged cover for ease of access during installation.

FEATURES

- Attractive compact hinge design
- Suitable for indoor wall- or floor-mounted applications
- Effective management of optical fibre
- Splice tray can be removed when required during installation or operation
- Adapters: SC Simplex and LC Duplex
- Adaptor slots
- Temperature: -40°C to +75°C
- Dimensions: 86mm x 86mm x 27mm
- Easy installation

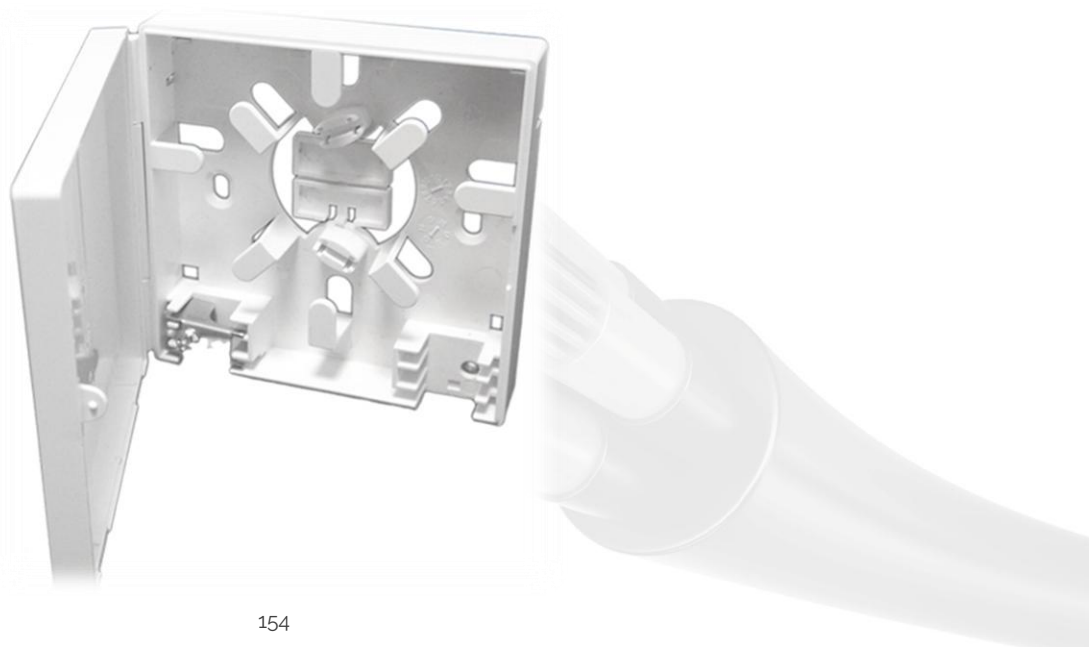

FTTH Box with Perspex Cover



STRUCTURE DIAGRAM & DESCRIPTION

Made from high impact ABS plastics, these customer outlets are widely used in access networks and FTTH applications. The outlets can be used for both surface-mount and concealed panel installations.

SPECIFICATIONS

Size (H*W*D) mm	86*115*23
Color	White
Material	ABS+PC
Capacity (Fibres)	1, 2, 4
Connect Models	Splicing, Mechanical Connector, FMC
Installation Models	Wall Mounted
Protective Level	IP4X
Pigtail	G.657 Φ 0.9mm, 0.5m Or customer request
Drop cable (Flat)	Indoor Flat Drop cable 2mm*3mm
Drop cable (Round)	Φ 5mm ~ Φ 7mm
Curvature Radius (mm)	\geq 15
Working Temp.	-25°C ~ + 60°C
Storage Temp.	-40°C ~ + 70°C
Humidity	93% (+30oC)
Air Pressure	70KPa ~ 106KPa



FTTH Compact IP65 Termination Box



STRUCTURE DIAGRAM & DESCRIPTION

The FTTH compact IP65 termination box is used for the distribution and termination of fibre optic cable devices. The IP-rated box can be utilised for FTTH applications and other installation requirements to break-out and splice input cables into drop cables, pigtails, or direct patching. The box can also be used for protective interconnection of a fibre network and is suitable for outdoor, riser and tunnel installations. It has a capacity for up to 4x SC Simplex & LC Duplex adapters.

FEATURES

- The closure is made from anti-aging materials with ultraviolet protective characteristics
- The sealing mechanism is based on pressed rubber/silicon strips and is IP65-rated
- Capacity: 4 port SC Simplex / LC Duplex
- Operating Temperature: -20°C~+70°C
- Storage: -40°C~+80°C
- Spare loops of pigtails and drop cables can be stowed in the storage compartment for convenience or for maintenance

DIMENSIONS (Including Lid)

- 186mm x 114mm x 40mm



FTTH Fibre Optic Terminal Box 8F

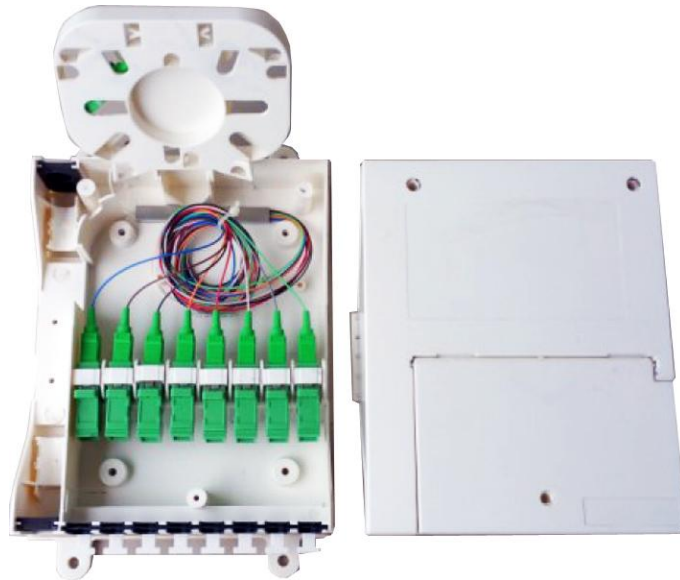

SPECIFICATION

Function	Cable splicing distribution & PLC splitter distribution
Splitter type	Tube type splitter
Adaptor type	LC or SC
Max ratio	1:8
Splice tray Cores	8F
Splice tray quantity	1pc
Cable	Drop cable, standard indoor cable
Dimension	190*126*46mm
Optional accessory	PLC splitter, SC adaptor, LC duplex adaptor

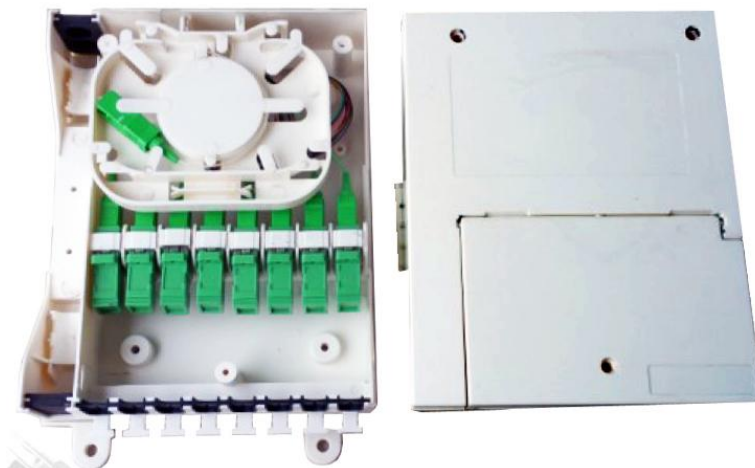

FTTH Fibre Optic Terminal Box (up to 16 fibres)

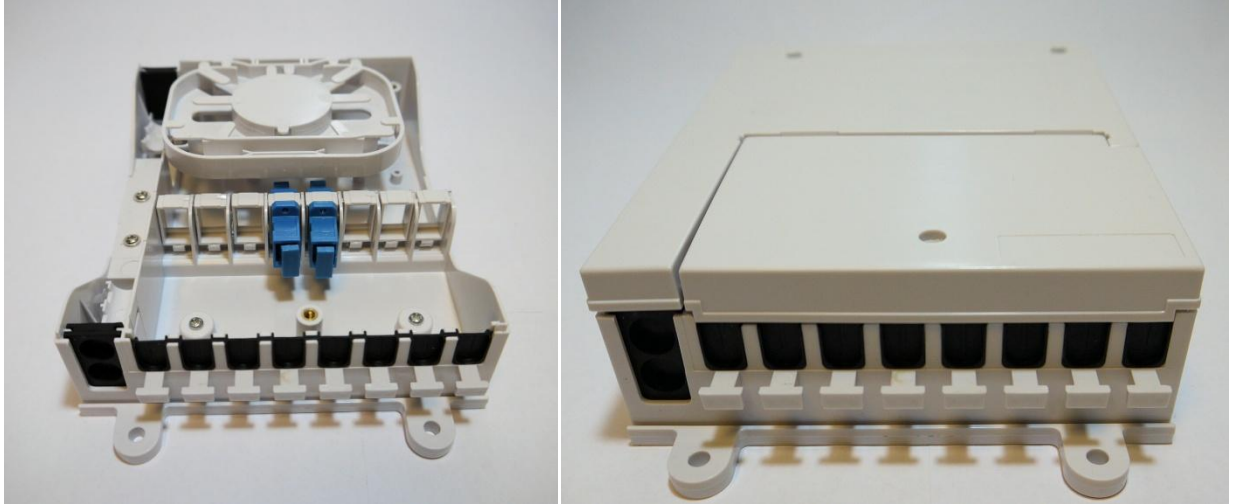

SPECIFICATIONS

Function	Cable splicing distribution & PLC splitter distribution
Splitter type	Tube type splitter
Adaptor type	SC Simplex or LC Duplex
Max ratio	1:8
Splice tray fibres	8F
Splice tray quantity	1pc
Cable	Drop cable, standard indoor cable
Dimensions	190*126*46mm
Optional accessories	PLC splitter, SC Simplex or LC Duplex accessories

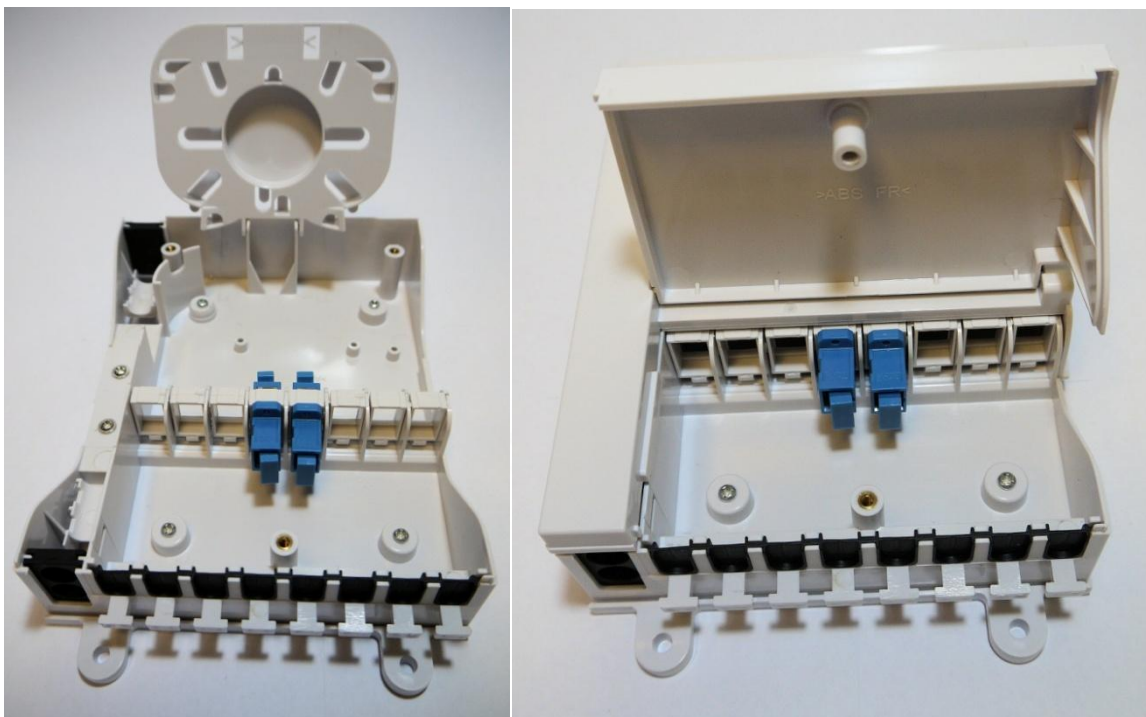

Fibre & Copper (CAT5E/6) Outlet, FTTH Outlet & FTTH Wall Plate



FIBRE & COPPER (CAT5E/6) OUTLET

The FTTH fibre and copper outlet is designed for SC Simplex or LC Duplex adapters and a RJ45 connection. It features a spring-loaded shutter cover for eye protection and to protect from contaminants. The lid is secured via a self-clipping design and a fibre storage compartment. Integrated heat shrink splice and mechanical splice holders are featured inside.

Dimensions (including lid):

Length: 86mm x Width: 86mm x Height: 26mm



FTTH OUTLET

The FTTH outlet is designed for SC Simplex or LC Duplex adapters with a spring-loaded shutter cover for eye protection and to protect from contaminants.

The lid is secured via a self-clipping design and a fibre storage compartment. Integrated heat shrink splice and mechanical splice holders are featured inside.

Dimensions (including lid):

Length: 86mm x Width: 86mm x Height: 26mm



FTTH WALL-PLATE

The FTTH Fiber Wall-plate is available for LC, FC, SC and ST adapters. An embedded section above the adapter entry port allows for clear labeling for ease of identification in a network. It is made of ABS plastic (white) with a detachable outer shell. It is ideal for both singlemode and multimode networks.

Dimensions (including lid):

Length: 86mm x Width: 86mm

FTTH Multi-Port Series Enclosures

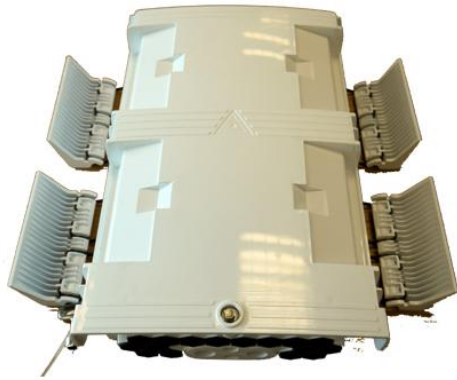

Model SA

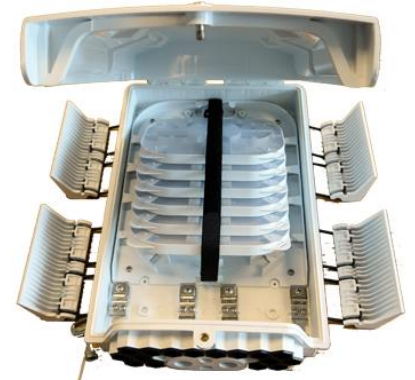

Model S

STRUCTURE DIAGRAM & DESCRIPTION

Made from high impact ABS plastics. The FTTH multi-port enclosures provide a cost-effective solution for point-to-point apartment or large premises fibre distribution.

FEATURES

- Secure enclosed structure with a tamperproof key lock
- Additional quad snap-locking clamps to support IP65 level protection
- Compartment for splicing and fibre routing
- Multiple cable entry/exit ports
- Accessories for exit port cable protection
- Can accept PG7 exit port glands
- Surface-mount or pole-mount achievable with additional bracket

SPECIFICATIONS

Overall dimensions	380x245x115
Color	White/Grey
Material	ABS+PC
Protection Level to	IP65
Drop Cable	Flat/Round
Input Cable	Multicore
Capacity Model S	72x splices
Capacity Model SA	36x splices + 18x adapter ports
Working Temperature	-25°C/+60°C
Storage Temperature	-40°C/+70°C
Air Pressure to	70KPa - 106KPa

FTTH Flat Drop Cable Indoor (White)

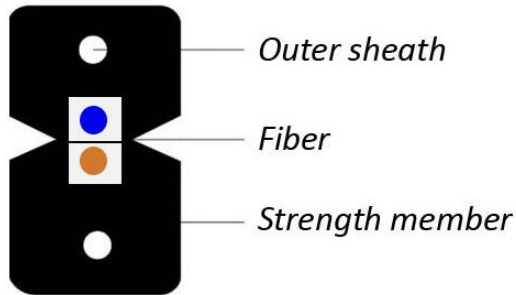

CHARACTERISTICS

- Simple structure, light weight, high tensile strength and metal-free.
- Novel groove design, easily strip and splice, simplified installation and maintenance.
- Low smoke, zero halogen and flame retardant sheath, environment-friendly, good safety.

Standard: Comply with standard YD/T1997-2009

STRUCTURE DIAGRAM & DESCRIPTION

The optical fibre unit is positioned in the centre. Two parallel Fibre Reinforced Plastics (FRP) or Steel wire are placed at the two sides. Then the cable is completed with a white / black LSZH sheath.

FIBRE ATTENUATION

Item Description		
G657A1 Fibre	atten.1310	≤ 0.40
	atten.1550	≤ 0.30dB/km

CABLE DIMENSIONS & CONSTRUCTION

Item Description		
Optical Fibre	Fibre count	1
Fiber Color	-	Blue
Strength Member	Material	Steel wire / FRP
	Diameter	0.4mm
Messenger wire	Material	Galvanized Steel Wire / Fibre Reinforced Plastics
	Diameter	1.1mm
Jacket	Material	LSZH
	Thickness	≥ 0.3mm
Cable Diameter	Width	5.2 mm
	Height	2.0 mm
Cable Weight	Net Weight	21

To be continued...

MECHANICAL & ENVIRONMENTAL CHARACTERISTICS			
Item Description			
Tensile performance	IEC 60794-1-2-E1	short-term	200N
		long-term	100N
Crush Resistance	IEC 60794-1-E3	short-term	2200N
		long-term	1000N
Cable Impact	IEC 60794-1-E4	No obvious change after test	
Repeat Bending	IEC 60794-1-E6		
Torsion	IEC 60794-1-E7		
Cable Bend	IEC 60794-1-E11		
Temperature Range	IEC 60794-1-2-F1	-20°C to +60°C	
Bending Radius	Static	15mm	
	Dynamic	30mm	

Packing: Wooden Drum in Carton Box

MARKING

For D1G5A1L-INWH:

OPTILITE OPTICAL DROP FTTH FIBRE CABLE – EXTERNAL – LSZH – 1X9/125 – G.657A1 – 2016 – BATCH xxxxm

For D2G5A1L-INWH:

OPTILITE OPTICAL DROP FTTH FIBRE CABLE – EXTERNAL – LSZH – 1X9/125 – G.657A2 – 2016 – BATCH xxxxm

DELIVERY LENGTH

Standard delivery length is 1km/drum or 2km/drum

ITEM

DXG65A1Y-INWH

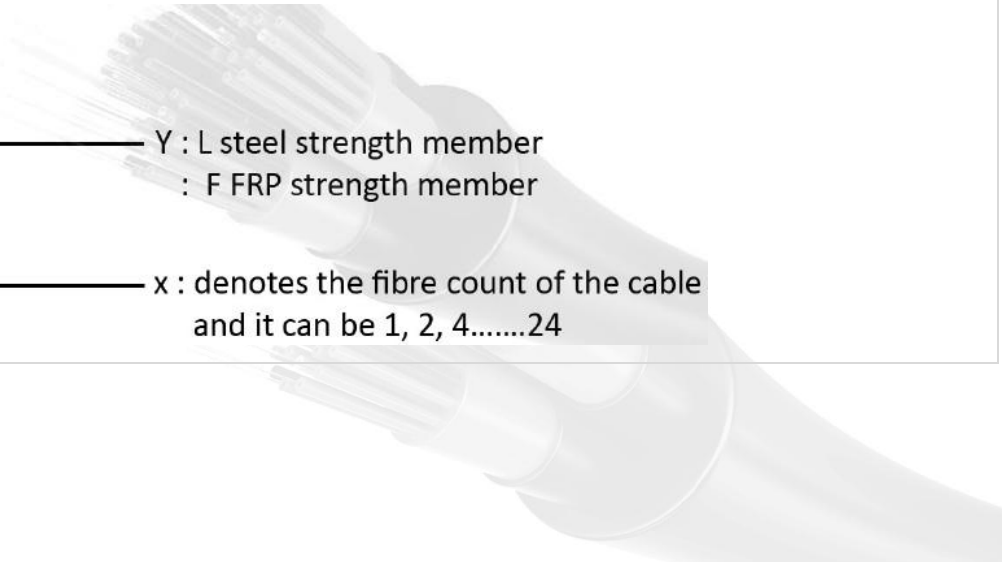

Y : L steel strength member
: F FRP strength member

x : denotes the fibre count of the cable and it can be 1, 2, 4.....24

FTTH Flat Drop Cable Outdoor (Black)

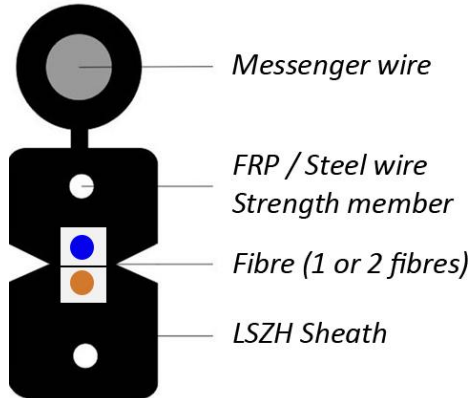

CHARACTERISTICS

- Novel groove design, easily strip and splice, simplified installation and maintenance, higher tensile strength
- Suitable as cable extending from outdoor (as aerial cable) to indoor
- Low smoke, zero halogen and flame retardant jacket, environment - friendly, good safety

Standard: Complies with standard YD/T1997-2009

STRUCTURE DIAGRAM & DESCRIPTION

The optical fibre unit is positioned in the centre. Two parallel fibre reinforced plastics (FRP) or steel wire are placed at the two sides. There is an additional steel wire strength member. The cable outer jacket is black and LSZH with one or two fibres.

FIBRE ATTENUATION

Item Description		
Singlemode G657A1 or G657A2 Fibre	atten.1310	≤ 0.40
	atten.1383	≤ 0.33dB/km
	atten.1550	≤ 0.30dB/km

CABLE DIMENSIONS & CONSTRUCTION

Item Description		
Optical Fiber	Fiber count	1
Fiber Color	-	Blue
Strength Member	Material	Steel wire / FRP
	Diameter	0.4mm
Messenger wire	Material	Galvanized Steel Wire / Fibre Reinforced Plastics
	Diameter	1.1mm
Jacket	Material	LSZH
	Thickness	≥ 0.3mm
Cable Diameter	Width	5.2 mm
	Height	2.0 mm
Cable Weight	Net Weight	21

To be continued...

MECHANICAL & ENVIRONMENTAL CHARACTERISTICS			
Item Description			
Tensile performance	IEC 60794-1-2-E1	short-term	500N
		long-term	250N
Crush Resistance	IEC 60794-1-E3	short-term	2200N
		long-term	1000N
Cable Impact	IEC 60794-1-E4	No obvious change after test	
Repeat Bending	IEC 60794-1-E6		
Torsion	IEC 60794-1-E7		
Cable Bend	IEC 60794-1-E11		
Temperature Range	IEC 60794-1-2-F1	-40 ⁰ C to +70 ⁰ C	
Bending Radius	Static	15mm	
	Dynamic	30mm	

Packing: Wooden Drum in Carton Box

MARKING

For 657A1SSDRP1-LS:

OPTILITE OPTICAL DROP FTTH FIBRE CABLE – EXTERNAL – LSZH – 1X9/125 – G.657A1 – 2016 – BATCH xxxxm

For 657A2SSDRP1-LS:

OPTILITE OPTICAL DROP FTTH FIBRE CABLE – EXTERNAL – LSZH – 1X9/125 – G.657A2 – 2016 – BATCH xxxxm

DELIVERY LENGTH

Standard delivery length is 1km/drum or 2km/drum

ITEM				
CABLE TYPE	STRENGTH MEMBER	FIBRE COUNT	CABLE SIZE (MM)	CABLE WEIGHT (KG/KM)
657A1SSDRP1-LS	Steel wire	1	2.0mm * 5.2m	21
657A1SSDRP2-LS		2	2.0mm * 5.2m	21
657A1SSDRP1-LF	FRP	1	2.0mm * 5.2m	18.9
657A1SSDRP2-LF		2	2.0mm * 5.2m	18.9



**TOOLS/TEST &
MEASUREMENT**

Tri-Hole Strippers and Ratchet Crimp Tool



STRUCTURE DIAGRAM & DESCRIPTION

TRI-HOLE “SURE-GRIP” & “LITE-GRIP” FIBRE STRIPPERS

Tri-Hole “Sure-Grip” Fibre Stripper (pictured left) This fibre stripper features 3 guides which are used to remove 2/3mm outer jackets, 900µm buffer insulation and 250µm acrylic coating.

This leaves 125µm bare fibre exposed for termination. **Tri-Hole “Lite-Grip” Fibre Stripper** (pictured right) 3 factory set stripping guides similar to the “Sure-Grip” tri-hole stripper, but in a lighter, more portable size. Has a hook latch for safety.

FEATURES

- Three factory set stripping guides: 2/3mm, 900µm, 250µm
- Comfortable handles
- Portable and lightweight design
- Diamond shaped blades for optimum stripping
- Hook latch for additional safety



STRUCTURE DIAGRAM & DESCRIPTION

Ratchet Crimp Tool (WITH INTERCHANGEABLE DIE SETS)

The ICL Ratchet Crimp Tool is a professional, heavy duty ratcheting crimp tool with adjustable tension for the purpose of securing the crimp ring in a connector.

Features replaceable die sets to meet the requirements of different crimping sizes.

FEATURES

- Replaceable die sets
- Die sets available in different sizes
- Carbon steel
- Heat-treated and with TPR handles

Pen Carbide Cleaver & Aramid Yarn Scissors



STRUCTURE DIAGRAM & DESCRIPTION

PEN CARBIDE CLEAVER

This carbide cleaver is presented in a pen style lightweight form, which is easy to carry and includes a protective clip-on cap. The 30° wedge angle ensures a precision cleave for speedy “use anywhere” fibre preparation.

FEATURES

- Compact pen cleaver
- Made from lightweight chrome-plated copper
- Tip material made from carbide
- Clip-on pocket storage
- Weight: 30 grams
- Overall length: 132mm
- Ideal for use with our field installable connectors
- Presented in a plastic case with sleeve



STRUCTURE DIAGRAM & DESCRIPTION

ARAMID YARN SCISSORS

Specially designed scissors for cutting through aramid yarn-lined fibre patchcords. Made from hardened steel with sharp serrated teeth and suitable for cutting a multimedia of materials.

FEATURES

- Sharp serrated teeth for cutting aramid yarn
- Robust and durable
- Ergonomic design
- Can be used on other materials

Pen-Type Visual Fault Identifier



STRUCTURE DIAGRAM & DESCRIPTION

The pen-type VFL is specially designed for field personnel who need an efficient and economical tool for fibre tracing, fibre routing and continuity checking in optical networks. It finds breakpoints, poor connections, bending or cracking in fibre optic cables. It can find faults in an OTDR dead zone and is used for end-to-end visual fibre identification.

FEATURES

- 2.5mm universal connector (1.25mm connector optional)
- Operates either in CW or Pulsed mode with constant output power
- Low battery warning
- Long battery life (up to 60 hours)
- Drop-resistant and dust-proof design of laser head
- Laser case ground design prevents ESD damage
- Portable and rugged
- Easy to use



SPECIFICATIONS

Central Wavelength	nm	650 ± 20
Output Power *	mw	1 >10 >15 >20 >25
Dynamic Distance **	km	3~5 8~10 12~14 15~17 18~20
Connector ***	-	2.5mm or 1.25mm Universal connector
Power Supply	-	AA * 2
Operating temperature	°C	-10 ~ +50, < 90%RH
Storage temperature	°C	-20 ~ +60, < 90%RH
Weight	g	80



* Tested by FOD1205H 650nm optical power meter

** The distance is tested by G.655, single mode, lab level fiber

*** Standard connector is 2.5mm UPP, 1.25mm UPP will be customised and will increase the price

Handheld Adjustable Light Source O-Laser Source 1



STRUCTURE DIAGRAM & DESCRIPTION

This Handheld Adjustable Light Source is our newly designed fibre optic tester, it is aimed at fiber network installations, fibre network engineering testing and fibre network maintenance. Combined usage with our handheld optical power meter, it offers a quick and accurate testing solution on both SM and MM fibers. The Lasersource1 provides 1 to 4 wavelengths and output power can be adjustable to customer requirements.

FEATURES

- Wave ID information can be transmitted when used with our Optical Power Meter.
- Tone generation, 270HZ, 330HZ, 1KHZ, 2KHZ
- Output power can be adjusted
- Output power value is shown on LCD display
- Intelligent backlight control (light intensity can be adjusted according to ambient light, which greatly reduces power consumption)
- AA alkaline and AC adapter for power supply
- Low battery indication

SPECIFICATIONS

Model	O-Lasersource1
Operating wavelength (nm)	10/1550;1310/1490/1550/1625 (others available on request)
Applicable fiber	SM, MM
Laser type	FP-LD (others available on request)
Output Power (dBm)	-5~-12dBm (adjustable)
Adjustable step size (dBm)	< 0.5
Stability (dB, 30min, 20°C)	0.15
Modulation (Hz)	CW, 270, 330, 1K, 2K
Fibre Port	FC/PC
Alkaline Battery	3*AA, 1.5V
Power Supply Adaptor(V)	8.4
Battery Operating time(h)	45
Operation Temperature (°C)	-10~+60
Storage Temperature (°C)	-25~+70
Outline size (mm) / weight	180*90*45(250g)

STANDARD PACKAGE

- Includes - Optical Light Source, 3pcs 1.5V batteries, AC Adaptor, User Manual, Cotton swabs and Soft carrying case.

Handheld Optical Power Meter



STRUCTURE DIAGRAM & DESCRIPTION

The OptiSmart handheld Optical Power Meter is our newly designed fibre optic tester, aimed at fibre network installers, fibre network engineers and fibre network maintenance personnel. It is aesthetically designed. Combined with the OptiSmart handheld optical light source, it offers quick and accurate testing on both SM and MM fibers. The unit includes automatic wavelength identification & switching and intelligent backlight control.

FEATURES

- Wave ID—Automatic wavelength identification and switching (when used with a handheld light source)
- Frequency ID/Tone detection - Automatic frequency identification
- Intelligent backlight control (light intensity can be adjusted properly according to ambient light, which greatly reduces power consumption)
- Data storage function, up to 1000 test results
- USB communication port for downloading test results
- Reference power level set up and storage
- Self calibration function
- Auto-off function can be activated or deactivated
- AA alkaline and AC adapter for power supply
- Low battery indication

SPECIFICATIONS

Model	O-Lasersource1
Calibrated (nm)	850, 1300,1310,1490,1550,1625
Detector Type	InGaAs
Measurement Range (dBm)	-70~+6 and -50~+26
Uncertainty (dB)	± 0.15(3.5%)
linearity (dB)	± 0.02
Display Resolution (dB)	0.01
Frequency ID (Hz)	270, 330, 1K, 2K
Wave ID (nm)	1310, 1490, 1550, 1625
Date Storage Capacity	1000
Communication Port	USB
Optical Connector Type	FC, SC, ST interchangeable
Alkaline Battery	3*AA, 1.5V
Power Supply Adaptor(V)	8.4
Battery Operating time(h)	45
Operation Temperature (°C)	-10~+60
Storage Temperature (°C)	-25~+70
Outline size (mm) / weight	180*90*45(250g)

STANDARD PACKAGE

- MODEL 700 & 800 (Includes) - Optical Power Meter, 1.5V batteries, AC Adaptor, Manual, Swabs, Soft Case

OPTiSmart Optical Fibre Fusion Splicer (OPTISMART1200S)



STRUCTURE DIAGRAM & DESCRIPTION

The OPTISMART1200S splices diverse quartz optical fibres with a cladding diameter from 80um to 150um, including singlemode, multimode, non-zero dispersion, dispersion shifted and bend insensitive fibres. Primarily for permanent splicing of optical fibres, it's widely used in fibre communication projects and production testing of passive optical devices. With a typical splice time of 7 seconds, it features a 4.3 inch TFT colour LCD with touch screen functionality for ease of use.

SPECIFICATIONS

Model	OPTISMART1200S Optical Fibre Fusion Splicer
OPTISMART1200S	<ul style="list-style-type: none"> • Material: quartz • Fiber Types: singlemode, multimode, non-zero dispersion, dispersion shifted, bend-insensitive & erbium-doped fibers • Cladding diameter: 80-150 micron • Coating diameter: 0.1mm-1.0mm, 2.0mm, 3.0mm, 2.0mm*3.1mm
Heating	<ul style="list-style-type: none"> • Effective heating length \leq 60mm • Heating time: 10-255 seconds, programmable as required • Typical heating time: \leq 25s (standard 45mm sleeve), \leq 28s (standard 60mm sleeve)
Power Supply	<ul style="list-style-type: none"> • External DC power input Input voltage is 13.5\pm0.5V; input current \geq4.4A; socket center is positive. • Built-in lithium ion battery for power supply. The lithium ion battery is 11.1V, \geq5.2Ah; full charging time is approximately 2.5h

Dimensions & Weight	<ul style="list-style-type: none"> • Dimensions: W×H×D=120mm×130mm×154mm (without vibration-free rubber pad) • Weight: Weight: approximately 1.95kg (with the lithium ion battery), approximately 1.75kg without the lithium-ion battery)
Environmental Conditions	<ul style="list-style-type: none"> • Operating temperature: -10°C~+50°C • Temperature limit: -20°C~+55°C • Operating humidity: 95%RH and below(non-condensing) • Max. wind speed: 15m/s • Storage temperature: -40°C~+80°C • Storage humidity: 95%RH and below (non-condensing)
Splice Loss	<p><u>Typical loss values of spliced points are:</u></p> <ul style="list-style-type: none"> • Singlemode fibre: 0.03dB • Multimode fibre: 0.01dB • Dispersion shifted fiber: 0.04dB • Non-zero dispersion shifted fiber: 0.04dB
Other	<ul style="list-style-type: none"> • Typical splice time: 7s(FAST mode, typical) • Monitor: with touch screen function, 4.3 inch TFT color LCD • USB port: system update and data transmission • Real-time display of remaining battery capacity • Built-in lighting with high brightness, for convenient loading of fibers

Contents List

<ul style="list-style-type: none"> • Fusion Splicer • Fiber Cleaver • Fiber Coat Stripper • Internal Battery 	<ul style="list-style-type: none"> • Charger • AC Power Cord • 2G USB Flash Disk • Spare Electrodes (one pair) 	<ul style="list-style-type: none"> • Cooling Tray • Alcohol Pump Bottle • Carrying Case • Carrying Strip 	<ul style="list-style-type: none"> • User's Manual
--	--	--	---

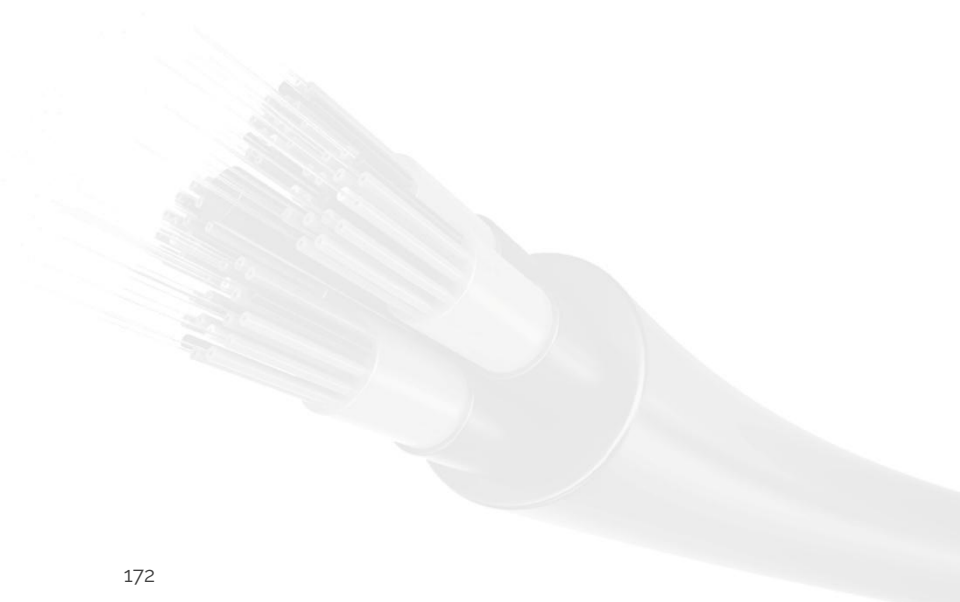

Optical Fibre Identifier



STRUCTURE DIAGRAM & DESCRIPTION

The optical fibre identifier can quickly identify the direction of the transmitted fibre and display the relative core power without any damage to the fibre. When traffic is present, an audible tone is activated. The unit can recognise modulation like 270Hz, 1kHz and 2kHz. When used to detect frequency, the continuous audible tone is activated. There are four adapter heads available: 250um, 900um, 2.0mm and 3.0mm. The optical fibre identifier is powered by a 9V alkaline battery.

FEATURES

- Easy-to-use with "ONE KEY" operation
- Efficiently identifies the traffic direction
- Detects frequency tone (270Hz, 1KHz, 2KHz) with audible warning
- Displays the relative core power
- More accurate tests with sunshade
- Easy-to-replace adaptors
- Durable metal housing and quality construction
- Lower power indication

SPECIFICATIONS	
Model	OSFI400
Identified Wavelength Range	• 800-1700 nm
Identified Signal Type	• CW, 270Hz±5%, 1kHz±5%, 2kHz±5%
Detector Type	• Ø1mm InGaAs 2pcs
Adapter Type	• 250um (Applicable for Bare Fiber), 900um (Applicable for 900um Cable) • 2.0mm (Applicable for 2.0mm Cable), 3.0mm (Applicable for 3.0mm Cable)
Signal Direction	• Left & Right LED
Singe Direction Test Range(dBm, CW/0.9mm bare fiber)	• -46~10(1310nm) • -50~10(1550nm)
Signal Frequency Display (Hz)	• 270, 1k, 2k
Frequency Test Range(dBm, Average Value)	• 900um, 2mm, 3mm [-30~0 (270Hz,1KHz) & -25~0 (2KHz)] • 250um [-25~0 (1KHz,2KHz) & -20~0 (2KHz)]
Insertion Loss(dB, Typical Value)	• 0.8 (1310nm) & 2.5 (1550nm)
Alkaline Battery (V)	• 9
Operating Temperature (°C)	• -10—+60
Storage Temperature (°C)	• -25—+70
Dimensions (mm)	• 196X30.5X27
Weight (g)	• 200

STANDARD PACKAGE

- Includes - optical fibre identifier, 4pcs adapter heads, sunshade, alkaline battery, user manual, cotton swabs and soft carrying case

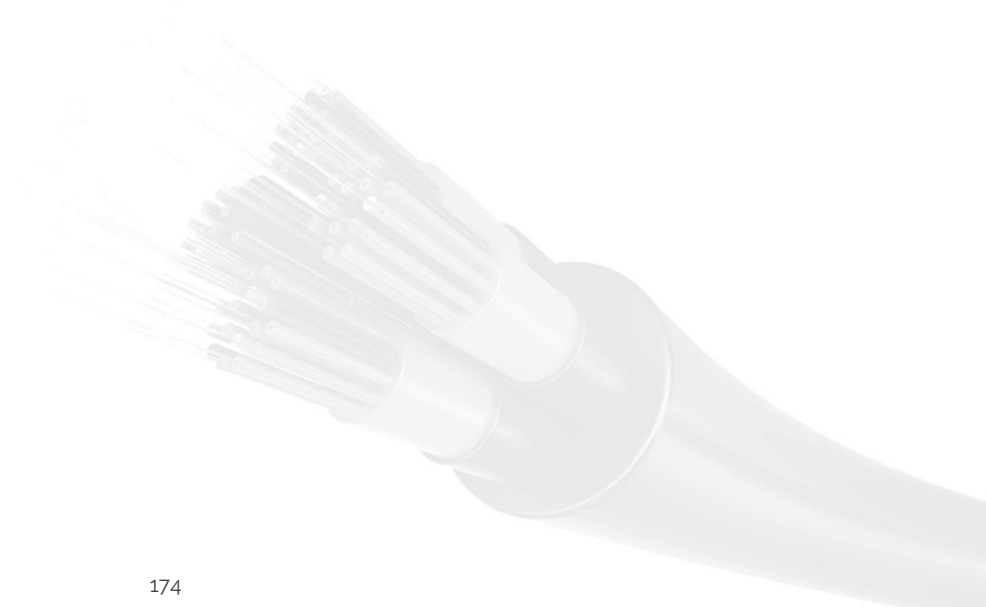

Fibre Cleaver with Fibre Collector



STRUCTURE DIAGRAM & DESCRIPTION

A small, compact and high quality fibre cleaver, it is designed for excellent portability and is ideal for use in the field with our field installable connectors (FIC) or with FTTx applications. Available in various versions, including one with an auto return feature, narrow lid or with a fibre collection bin. Can be included as part of a termination kit.

FEATURES

- Easy to use
- Small size
- Easy handling
- High cutting quality
- Fibre collection bin for safety

SPECIFICATIONS

CLEAVER WITH FIBRE COLLECTION BIN

Bare fibre diameter	125um
Coating fibre diameter	250um, 900um
Cleaving length	250um: 9-16mm , 900um: 10-16mm
Blade life	54000 fibers (1500 fiber x 3 feet x 12 positions)
Fiber dustbin	Yes
Auto-Return	No
Size	95 x 90 x 65mm
Net Weight	Approximately 420g



INTELLIGENT COMMS LIMITED
London, United Kingdom